



Hardware Installation Guide for the Cisco 4000 Series Integrated Services Router

Last Updated: November 30, 2014

Cisco Systems, Inc.
www.cisco.com

Cisco has more than 200 offices worldwide. Addresses, phone numbers, and fax numbers are listed on the Cisco website at www.cisco.com/go/offices.

Text Part Number: OL-32185-02

THE SPECIFICATIONS AND INFORMATION REGARDING THE PRODUCTS IN THIS MANUAL ARE SUBJECT TO CHANGE WITHOUT NOTICE. ALL STATEMENTS, INFORMATION, AND RECOMMENDATIONS IN THIS MANUAL ARE BELIEVED TO BE ACCURATE BUT ARE PRESENTED WITHOUT WARRANTY OF ANY KIND, EXPRESS OR IMPLIED. USERS MUST TAKE FULL RESPONSIBILITY FOR THEIR APPLICATION OF ANY PRODUCTS.

THE SOFTWARE LICENSE AND LIMITED WARRANTY FOR THE ACCOMPANYING PRODUCT ARE SET FORTH IN THE INFORMATION PACKET THAT SHIPPED WITH THE PRODUCT AND ARE INCORPORATED HEREIN BY THIS REFERENCE. IF YOU ARE UNABLE TO LOCATE THE SOFTWARE LICENSE OR LIMITED WARRANTY, CONTACT YOUR CISCO REPRESENTATIVE FOR A COPY.

The following information is for FCC compliance of Class A devices: This equipment has been tested and found to comply with the limits for a Class A digital device, pursuant to part 15 of the FCC rules. These limits are designed to provide reasonable protection against harmful interference when the equipment is operated in a commercial environment. This equipment generates, uses, and can radiate radio-frequency energy and, if not installed and used in accordance with the instruction manual, may cause harmful interference to radio communications. Operation of this equipment in a residential area is likely to cause harmful interference, in which case users will be required to correct the interference at their own expense.

The following information is for FCC compliance of Class B devices: This equipment has been tested and found to comply with the limits for a Class B digital device, pursuant to part 15 of the FCC rules. These limits are designed to provide reasonable protection against harmful interference in a residential installation. This equipment generates, uses and can radiate radio frequency energy and, if not installed and used in accordance with the instructions, may cause harmful interference to radio communications. However, there is no guarantee that interference will not occur in a particular installation. If the equipment causes interference to radio or television reception, which can be determined by turning the equipment off and on, users are encouraged to try to correct the interference by using one or more of the following measures:

- Reorient or relocate the receiving antenna.
- Increase the separation between the equipment and receiver.
- Connect the equipment into an outlet on a circuit different from that to which the receiver is connected.
- Consult the dealer or an experienced radio/TV technician for help.

Modifications to this product not authorized by Cisco could void the FCC approval and negate your authority to operate the product.

The Cisco implementation of TCP header compression is an adaptation of a program developed by the University of California, Berkeley (UCB) as part of UCB's public domain version of the UNIX operating system. All rights reserved. Copyright © 1981, Regents of the University of California.

NOTWITHSTANDING ANY OTHER WARRANTY HEREIN, ALL DOCUMENT FILES AND SOFTWARE OF THESE SUPPLIERS ARE PROVIDED "AS IS" WITH ALL FAULTS. CISCO AND THE ABOVE-NAMED SUPPLIERS DISCLAIM ALL WARRANTIES, EXPRESSED OR IMPLIED, INCLUDING, WITHOUT LIMITATION, THOSE OF MERCHANTABILITY, FITNESS FOR A PARTICULAR PURPOSE AND NONINFRINGEMENT OR ARISING FROM A COURSE OF DEALING, USAGE, OR TRADE PRACTICE.

IN NO EVENT SHALL CISCO OR ITS SUPPLIERS BE LIABLE FOR ANY INDIRECT, SPECIAL, CONSEQUENTIAL, OR INCIDENTAL DAMAGES, INCLUDING, WITHOUT LIMITATION, LOST PROFITS OR LOSS OR DAMAGE TO DATA ARISING OUT OF THE USE OR INABILITY TO USE THIS MANUAL, EVEN IF CISCO OR ITS SUPPLIERS HAVE BEEN ADVISED OF THE POSSIBILITY OF SUCH DAMAGES.

Cisco and the Cisco logo are trademarks or registered trademarks of Cisco and/or its affiliates in the U.S. and other countries. To view a list of Cisco trademarks, go to this URL: www.cisco.com/go/trademarks. Third-party trademarks mentioned are the property of their respective owners. The use of the word partner does not imply a partnership relationship between Cisco and any other company. (1110R)

Any Internet Protocol (IP) addresses and phone numbers used in this document are not intended to be actual addresses and phone numbers. Any examples, command display output, network topology diagrams, and other figures included in the document are shown for illustrative purposes only. Any use of actual IP addresses or phone numbers in illustrative content is unintentional and coincidental.

© 2016 Cisco Systems, Inc. All rights reserved.



Preface	xi
Objectives	xi
Audience	xi
Organization	xii
Conventions	xiii
Related Documentation	xix
Searching for Cisco Documents	xx
Obtaining Documentation and Submitting a Service Request	xx

CHAPTER 1

Overview of the Cisco 4000 Series ISR	1-1
About the Cisco 4000 Series ISR	1-1
Cisco 4451-X ISR	1-2
Cisco 4431 ISR	1-3
Cisco 4351 ISR	1-3
Cisco 4331 ISR	1-4
Cisco 4321 ISR	1-5
Cisco 4221 ISR	1-5
Safety Warnings	1-6
Safety Warnings for Finland, Norway, and Sweden	1-6
Chassis Views	1-6
Cisco 4451-X ISR Chassis	1-7
Platform Summary	1-10
Cisco 4431 ISR Chassis	1-10
Platform Summary	1-13
Cisco 4351 ISR Chassis	1-14
Platform Summary	1-16
Cisco 4331 ISR Chassis	1-17
Platform Summary	1-18
Cisco 4321 ISR Chassis	1-19
Platform Summary	1-20
Cisco 4221 ISR Chassis	1-21
Platform Summary	1-23
Hardware and Module Configuration	1-25

- Locating the Serial Number, PID, VID, and CLEI 1-25
 - Labels on the Router 1-26
 - For Additional Help Locating Labels on the Router 1-26
- Hardware Features 1-26
 - Built-In Interface Ports 1-27
 - Dual Mode GE/SFP Ports 1-27
 - USB Serial Console Port 1-27
 - Front Panel PoE+ Ports 1-27
 - Internal PoE Daughter Card 1-27
 - LED Indicators 1-28
 - Removable and Interchangeable Modules and Cards 1-34
 - Network Interface Modules and Service Modules 1-35
 - Cisco UCS E-Series Server Modules 1-35
 - System Flash 1-36
 - Solid State Drives 1-36
 - Packet Voice Digital Signal Processor Modules 1-36
 - Memory 1-37
 - Power Supply 1-37
 - Fans, Ventilation, and Airflow 1-38
- About Slots and Interfaces 1-39
 - About Slot, Subslot (Bay), and Port Numbering 1-40
 - Slot Numbering 1-41
 - About Slot 0 1-41
 - Subslot/Bay Numbering 1-42
 - Gigabit Ethernet Management 1-42
- Specifications 1-42
- Periodic Inspection and Cleaning 1-51

CHAPTER 2

- Preparing for Router Installation 2-1**
 - Standard Warning Statements 2-1
 - General Safety Warnings 2-2
 - Safety Recommendations 2-5
 - Safety with Electricity 2-6
 - Preventing Electrostatic Discharge Damage 2-7
 - General Site Requirements 2-7
 - General Precautions 2-7
 - Site Selection Guidelines 2-8
 - Site Environmental Requirements 2-8
 - Physical Characteristics 2-9

Rack Requirements	2-9
Router Environmental Requirements	2-10
Power Guidelines and Requirements	2-11
Network Cabling Specifications	2-11
Console and Auxiliary Port Considerations	2-11
Console Port Connections	2-12
Auxiliary Port Connections	2-13
Preparing for Network Connections	2-14
Ethernet Connections	2-14
Required Tools and Equipment for Installation and Maintenance	2-14
Installation Checklist	2-16
Creating a Site Log	2-17

CHAPTER 3

Installing and Connecting the Router	3-1
What You Need to Know	3-3
Before You Begin	3-3
Unpacking the Router	3-4
Installing the Router	3-4
Rack-Mounting the Chassis	3-5
Attaching Rack-Mount Brackets	3-5
Mounting the Router in a Rack	3-7
Attaching Wall-Mount Brackets to the Cisco 4431 ISR	3-10
Attaching the Cisco 4431 ISR to a Wall	3-10
Mounting the Cisco 4431 ISR in a Rack	3-12
Attaching Wall-Mount Brackets to the Cisco 4221 ISR	3-15
Attaching the Cisco 4221 ISR to a Wall	3-15
Mounting the Cisco 4221 ISR in a Rack	3-16
Mounting the Cisco 4221 ISR in a Rack with the DC Power Unit	3-18
Grounding the Chassis	3-21
Setting the Chassis on a Desktop	3-22
Chassis Grounding	3-22
Connecting Power	3-23
Connecting to AC Power	3-24
Connecting to a Console Terminal or Modem	3-25
Connecting to the Serial Port with Microsoft Windows	3-25
Connecting to the Console Port with Mac OS X	3-26
Connecting to the Console Port with Linux	3-27
Installing the Cisco Microsoft Windows USB Device Driver	3-27

Installing the Cisco Microsoft Windows XP USB Driver	3-28
Installing the Cisco Microsoft Windows 2000 USB Driver	3-28
Installing the Cisco Microsoft Windows Vista USB Driver	3-28
Uninstalling the Cisco Microsoft Windows USB Driver	3-29
Uninstalling the Cisco Microsoft Windows XP and 2000 USB Driver	3-29
Uninstalling the Cisco Microsoft Windows Vista USB Driver	3-30
Connecting WAN, LAN, and Voice Interfaces	3-30
Ports and Cabling	3-32
Connection Procedures and Precautions	3-32

CHAPTER 4

Initial Configuration 4-1

Performing the Initial Configuration on the Router	4-1
Using Cisco Setup Command Facility	4-1
Completing the Configuration	4-4
Using Cisco IOS XE CLI—Manual Configuration	4-5
Configuring the Router Hostname	4-6
Configuring the Enable and Enable Secret Passwords	4-7
Configuring the Console Idle Privileged EXEC Timeout	4-8
Gigabit Ethernet Management Interface Overview	4-10
Default Gigabit Ethernet Configuration	4-10
Gigabit Ethernet Port Numbering	4-10
Configuring Gigabit Ethernet Interfaces	4-10
Configuration Examples	4-12
Specifying a Default Route or Gateway of Last Resort	4-12
Configuring IP Routing and IP Protocols	4-13
Default Routes	4-13
Default Network	4-13
Gateway of Last Resort	4-13
Configuration Examples	4-15
Configuring Virtual Terminal Lines for Remote Console Access	4-16
Configuration Examples	4-17
Configuring the Auxiliary Line	4-18
Verifying Network Connectivity	4-19
Saving Your Router Configuration	4-20
Saving Backup Copies of Configuration and System Image	4-20
Configuration Examples	4-21
Verifying the Initial Configuration	4-23

CHAPTER 5**ROM Monitor Overview and Basic Procedures 5-1**

- ROM Monitor Overview 5-1
- Entering ROM Monitor Mode 5-2
 - Checking the Current ROMmon Version 5-2
 - Commonly Used ROM Monitor Commands 5-4
 - Displaying the Available ROM Monitor Commands 5-5
 - Examples 5-5
 - Changing the ROM Monitor Prompt 5-5
- Displaying the Configuration Register Setting 5-6
- Environment Variable Settings 5-6
 - Frequently Used Environmental Variables 5-7
 - Displaying Environment Variable Settings 5-7
 - Entering Environment Variable Settings 5-8
 - Saving Environment Variable Settings 5-8
- Exiting ROM Monitor Mode 5-8
 - Configuration Example 5-9
 - Upgrading the ROMmon for a Router 5-9

CHAPTER 6**Installing and Upgrading Internal Modules and FRUs 6-1**

- Safety Warnings 6-2
- Modules Supported 6-4
- Accessing Internal Modules 6-5
 - Replacing the Chassis Cover 6-5
 - Removing the Cover 6-5
 - Replacing the Cover 6-5
- Locating Internal and External Slots for Modules 6-6
- Locating Internal and External Slots for Modules on the Cisco 4331 ISR Router 6-9
 - 6-10
- Overview of the SSD Carrier Card NIM (NIM-SSD) 6-10
 - Overview 6-10
 - LEDs on the NIM-SSD 6-12
 - Solid State Drives 6-14
 - Installing the SSD Drives into the NIM Carrier Card 6-16
 - Removing the SSD Drives from the NIM-SSD 6-17
- Overview of the NIM-HDD Card 6-19
 - Cisco NIM-HDD LEDs 6-21
- Removing and Replacing the Cisco NIM-SSD or NIM-HDD 6-21
 - Removing the NIM-SSD or NIM-HDD from the Router 6-23

- Replacing the NIM-SSD or NIM-HDD on the Router 6-24
- Installing and Removing DDR DIMMs 6-24
 - Locating and Orienting DIMM 6-24
 - Removing a DIMM 6-25
 - Installing a DIMM 6-27
- Installing and Removing NIMs and SM-Xs 6-29
 - Software Requirement for SM-Xs 6-30
 - Locating an SM-X or NIM 6-30
 - Removing an SM-X or NIM 6-30
 - Installing an SM-X 6-30
 - Verifying SM-X Installation 6-31
- Installing and Removing the PVDM4 6-31
 - Tools and Equipment Required 6-32
 - PVDM4 Location and Orientation 6-32
 - Installing the PVDM4 on the Motherboard of the Router 6-33
 - Removing the PVDM4 from the Motherboard of the Router 6-34
 - Installing the PVDM4 on the Motherboard of the Cisco 4331 ISR Router 6-35
 - Removing the PVDM4 from the Motherboard of the Cisco 4331 ISR Router 6-36
 - Installing the PVDM4 on the Cisco Fourth-Generation T1/E1 Voice and WAN NIM 6-37
 - Removing the PVDM4 from the Cisco Fourth-Generation T1/E1 Voice and WAN NIM 6-38
- Removing and Replacing the USB Flash Token Memory Stick 6-38
- Removing and Replacing the Cisco 4000 Series ISRs Power Supplies 6-39
 - AC Power Supplies 6-40
 - Overview of the AC Power Supply 6-40
 - Replacing the AC Power Supply 6-41
 - DC Power Supply 6-43
 - Overview of the DC Power Supply 6-43
 - Removing DC Input Power from the Cisco 4431 ISR Router 6-44
 - Installing DC Input Power on the Cisco ISR4431 Router 6-45
 - Replacing the Power Supply Module from the Cisco 4331 Router 6-48
 - Overview of the DC Power Supply for Cisco 4221 ISR 6-49
- PoE Converter Power Supply Unit 6-50
 - Overview of the PoE Converter Power Supply Unit 6-51
 - Removing the PoE Power Supply Slot Filler 6-51
 - Installing the PoE Converter Power Supply 6-52
 - Removing the PoE Converter Power Supply 6-52
 - Installing the PoE Power Supply Slot Filler 6-53
- Replacing a Fan Tray 6-55
 - Before Hot-Swapping a Fan Tray 6-55

Replacing the Fan Tray	6-55	
Replacing the Fan Tray on a Cisco 4331 ISR	6-56	
Removing and Installing a CompactFlash Memory Card		6-60
Preventing Electrostatic Discharge Damage	6-60	
Removing a CompactFlash Memory Card	6-61	
Installing a CompactFlash Memory Card	6-62	
Removing and Installing a Flash Memory Card		6-62
Preventing Electrostatic Discharge Damage	6-63	
Installing the Flash Memory Card	6-63	
Removing the Flash Memory Card	6-65	
Installing and Removing an SSD mSATA Storage Device		6-65
Preventing Electrostatic Discharge Damage	6-65	
Installing the SSD mSATA Storage Device	6-66	
Removing the SSD mSATA Storage Device	6-67	
Installing and Removing SFP Modules		6-68
Installing SFPs	6-70	
Laser Safety Guidelines	6-70	
Removing SFP Modules	6-71	
Removing, Replacing, and Installing an Internal PoE Daughter Card		6-72

APPENDIX A**Online Insertion and Removal and Hot-Swapping** A-1

OIR Procedures	A-2
Removing a Module	A-2
Inserting a Data or Voice Module	A-2
Hot-Swapping Procedures	A-2

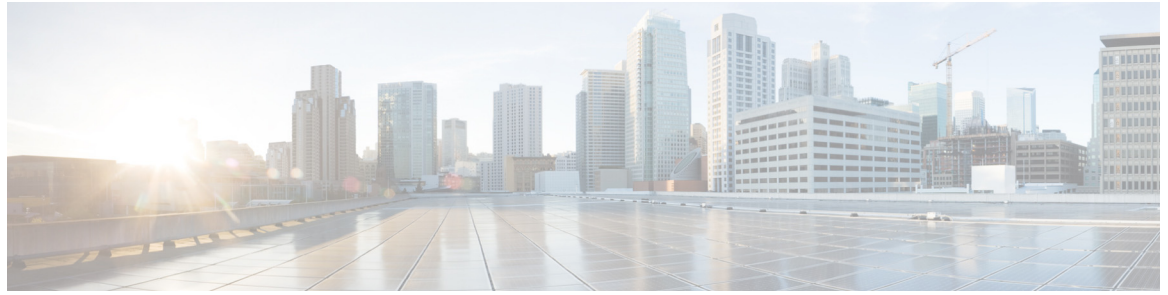

Preface

This preface describes the objectives, audience, organization and conventions of this guide, and the references that accompany this document set.

- [Objectives, page xi](#)
- [Audience, page xi](#)
- [Organization, page xii](#)
- [Conventions, page xiii](#)
- [Related Documentation, page xix](#)
- [Searching for Cisco Documents, page xx](#)
- [Obtaining Documentation and Submitting a Service Request, page xx](#)

Objectives

This guide explains how to install, connect, and perform initial configurations for the Cisco 4000 Series Integrated Services Router (ISR)



Note

For warranty, service, and support information, see the “Cisco Warranty Terms” section in the *Pointer Card for the Cisco 4400 and Cisco 4300 Series Integrated Services Routers* document that was shipped with your router.

Audience

This guide is intended for Cisco equipment providers and service persons who are technically knowledgeable and familiar with Cisco routers and Cisco IOS software and features. They would understand how to install, configure, and maintain the router, and they should be familiar with electronic circuitry and wiring practices, and have experience as an electronic or electromechanical technician. This guide identifies certain procedures that should be performed only by trained and qualified personnel.

Organization

This guide includes the following chapters and appendix:

Chapter/Appendix	Title	Description
Chapter 1	Overview of the Cisco 4000 Series ISR	Describes the router chassis views, information for locating the serial number, PID ¹ , and UDI ² . Also includes general hardware features, slot, port and interface information, and LED indicators.
Chapter 2	Preparing for Router Installation	Describes site requirements and the equipment needed to install the router.
Chapter 3	Installing and Connecting the Router	Describes how to install and connect the router to LAN, WAN, and Voice networks.
Chapter 4	Initial Configuration	Describes how to power up the router and perform the initial configuration.
Chapter 5	ROM Monitor Overview and Basic Procedures	Provides an overview of ROM Monitor concepts and operations.
Chapter 6	Installing and Upgrading Internal Modules and FRUs	Describes how to install and upgrade internal modules and field replaceable units ³ on the router.
Appendix A	Online Insertion and Removal and Hot-Swapping	Describes how to remove and replace data and modules using the online insertion and removal ⁴ procedure.

1. PID = Product ID
2. UDI = Universal Device Identifier
3. FRU = Field Replaceable Unit
4. OIR = Online Insertion and Removal

Conventions

This document uses the following conventions:

Convention	Indication
bold font	Commands and keywords and user-entered text appear in bold font .
<i>italic font</i>	Document titles, new or emphasized terms, and arguments for which you supply values are in <i>italic font</i> .
[]	Elements in square brackets are optional.
{ x y z }	Required alternative keywords are grouped in braces and separated by vertical bars.
[x y z]	Optional alternative keywords are grouped in brackets and separated by vertical bars.
string	A nonquoted set of characters. Do not use quotation marks around the string or the string will include the quotation marks.
<code>courier font</code>	Terminal sessions and information the system displays appear in <code>courier font</code> .
< >	Nonprinting characters such as passwords are in angle brackets.
[]	Default responses to system prompts are in square brackets.
!, #	An exclamation point (!) or a pound sign (#) at the beginning of a line of code indicates a comment line.



Note

Means *reader take note*.



Tip

Means *the following information will help you solve a problem*.



Caution

Means *reader be careful*. In this situation, you might perform an action that could result in equipment damage or loss of data.



Timesaver

Means *the described action saves time*. You can save time by performing the action described in the paragraph.



Warning

IMPORTANT SAFETY INSTRUCTIONS

This warning symbol means danger. You are in a situation that could cause bodily injury. Before you work on any equipment, be aware of the hazards involved with electrical circuitry and be familiar with standard practices for preventing accidents. Use the statement number provided at the end of each warning to locate its translation in the translated safety warnings that accompanied this device. Statement 1071

SAVE THESE INSTRUCTIONS

Waarschuwing

BELANGRIJKE VEILIGHEIDSINSTRUCTIES

Dit waarschuwingssymbool betekent gevaar. U verkeert in een situatie die lichamelijk letsel kan veroorzaken. Voordat u aan enige apparatuur gaat werken, dient u zich bewust te zijn van de bij elektrische schakelingen betrokken risico's en dient u op de hoogte te zijn van de standaard praktijken om ongelukken te voorkomen. Gebruik het nummer van de verklaring onderaan de waarschuwing als u een vertaling van de waarschuwing die bij het apparaat wordt geleverd, wilt raadplegen.

BEWAAR DEZE INSTRUCTIES

Varoitus

TÄRKEITÄ TURVALLISUUSOHJEITA

Tämä varoitusmerkki merkitsee vaaraa. Tilanne voi aiheuttaa ruumiillisia vammoja. Ennen kuin käsittelet laitteistoa, huomioi sähköpiirien käsittelemiseen liittyvät riskit ja tutustu onnettomuuksien yleisiin ehkäisytapoihin. Turvallisuusvaroitusten käännökset löytyvät laitteen mukana toimitettujen käännettyjen turvallisuusvaroitusten joukosta varoitusten lopussa näkyvien lausuntonumeroiden avulla.

SÄILYTÄ NÄMÄ OHJEET

Attention

IMPORTANTES INFORMATIONS DE SÉCURITÉ

Ce symbole d'avertissement indique un danger. Vous vous trouvez dans une situation pouvant entraîner des blessures ou des dommages corporels. Avant de travailler sur un équipement, soyez conscient des dangers liés aux circuits électriques et familiarisez-vous avec les procédures couramment utilisées pour éviter les accidents. Pour prendre connaissance des traductions des avertissements figurant dans les consignes de sécurité traduites qui accompagnent cet appareil, référez-vous au numéro de l'instruction situé à la fin de chaque avertissement.

CONSERVEZ CES INFORMATIONS

Warnung

WICHTIGE SICHERHEITSHINWEISE

Dieses Warnsymbol bedeutet Gefahr. Sie befinden sich in einer Situation, die zu Verletzungen führen kann. Machen Sie sich vor der Arbeit mit Geräten mit den Gefahren elektrischer Schaltungen und den üblichen Verfahren zur Vorbeugung vor Unfällen vertraut. Suchen Sie mit der am Ende jeder Warnung angegebenen Anweisungsnummer nach der jeweiligen Übersetzung in den übersetzten Sicherheitshinweisen, die zusammen mit diesem Gerät ausgeliefert wurden.

BEWAHREN SIE DIESE HINWEISE GUT AUF.

Avvertenza IMPORTANTI ISTRUZIONI SULLA SICUREZZA

Questo simbolo di avvertenza indica un pericolo. La situazione potrebbe causare infortuni alle persone. Prima di intervenire su qualsiasi apparecchiatura, occorre essere al corrente dei pericoli relativi ai circuiti elettrici e conoscere le procedure standard per la prevenzione di incidenti. Utilizzare il numero di istruzione presente alla fine di ciascuna avvertenza per individuare le traduzioni delle avvertenze riportate in questo documento.

CONSERVARE QUESTE ISTRUZIONI

Advarsel VIKTIGE SIKKERHETSINSTRUKSJONER

Dette advarselssymbolet betyr fare. Du er i en situasjon som kan føre til skade på person. Før du begynner å arbeide med noe av utstyret, må du være oppmerksom på farene forbundet med elektriske kretser, og kjenne til standardprosedyrer for å forhindre ulykker. Bruk nummeret i slutten av hver advarsel for å finne oversettelsen i de oversatte sikkerhetsadvarslene som fulgte med denne enheten.

TA VARE PÅ DISSE INSTRUKSJONENE

Aviso INSTRUÇÕES IMPORTANTES DE SEGURANÇA

Este símbolo de aviso significa perigo. Você está em uma situação que poderá ser causadora de lesões corporais. Antes de iniciar a utilização de qualquer equipamento, tenha conhecimento dos perigos envolvidos no manuseio de circuitos elétricos e familiarize-se com as práticas habituais de prevenção de acidentes. Utilize o número da instrução fornecido ao final de cada aviso para localizar sua tradução nos avisos de segurança traduzidos que acompanham este dispositivo.

GUARDE ESTAS INSTRUÇÕES

¡Advertencia! INSTRUCCIONES IMPORTANTES DE SEGURIDAD

Este símbolo de aviso indica peligro. Existe riesgo para su integridad física. Antes de manipular cualquier equipo, considere los riesgos de la corriente eléctrica y familiarícese con los procedimientos estándar de prevención de accidentes. Al final de cada advertencia encontrará el número que le ayudará a encontrar el texto traducido en el apartado de traducciones que acompaña a este dispositivo.

GUARDE ESTAS INSTRUCCIONES

Varning! VIKTIGA SÄKERHETSANVISNINGAR

Denna varningssignal signalerar fara. Du befinner dig i en situation som kan leda till personskada. Innan du utför arbete på någon utrustning måste du vara medveten om farorna med elkretsar och känna till vanliga förfaranden för att förebygga olyckor. Använd det nummer som finns i slutet av varje varning för att hitta dess översättning i de översatta säkerhetsvarningar som medföljer denna anordning.

SPARA DESSA ANVISNINGAR

FONTOS BIZTONSÁGI ELOÍRÁSOK

Ez a figyelmeztető jel veszélyre utal. Sérülésveszélyt rejte helyzetben van. Mielott bármely berendezésen munkát végezte, legyen figyelemmel az elektromos áramkörök okozta kockázatokra, és ismerkedjen meg a szokásos balesetvédelmi eljárásokkal. A kiadványban szereplo figyelmeztetések fordítása a készülékhez mellékelt biztonsági figyelmeztetések között található; a fordítás az egyes figyelmeztetések végén látható szám alapján keresheto meg.

ORIZZE MEG EZEKET AZ UTASÍTÁSOKAT!

Предупреждение

ВАЖНЫЕ ИНСТРУКЦИИ ПО СОБЛЮДЕНИЮ ТЕХНИКИ БЕЗОПАСНОСТИ

Этот символ предупреждения обозначает опасность. То есть имеет место ситуация, в которой следует опасаться телесных повреждений. Перед эксплуатацией оборудования выясните, каким опасностям может подвергаться пользователь при использовании электрических цепей, и ознакомьтесь с правилами техники безопасности для предотвращения возможных несчастных случаев. Воспользуйтесь номером заявления, приведенным в конце каждого предупреждения, чтобы найти его переведенный вариант в переводе предупреждений по безопасности, прилагаемом к данному устройству.

СОХРАНИТЕ ЭТИ ИНСТРУКЦИИ

警告

重要的安全性说明

此警告符号代表危险。您正处于可能受到严重伤害的工作环境中。在您使用设备开始工作之前，必须充分意识到触电的危险，并熟练掌握防止事故发生的标准工作程序。请根据每项警告结尾提供的声明号码来找到此设备的安全性警告说明的翻译文本。

请保存这些安全性说明

警告

安全上の重要な注意事項

「危険」の意味です。人身事故を予防するための注意事項が記述されています。装置の取り扱い作業を行うときは、電気回路の危険性に注意し、一般的な事故防止策に留意してください。警告の各国語版は、各注意事項の番号を基に、装置に付属の「Translated Safety Warnings」を参照してください。

これらの注意事項を保管しておいてください。

주의

중요 안전 지침

이 경고 기호는 위험을 나타냅니다. 작업자가 신체 부상을 일으킬 수 있는 위험한 환경에 있습니다. 장비에 작업을 수행하기 전에 전기 회로와 관련된 위험을 숙지하고 표준 작업 관례를 숙지하여 사고를 방지하십시오. 각 경고의 마지막 부분에 있는 경고문 번호를 참조하여 이 장치와 함께 제공되는 번역된 안전 경고문에서 해당 번역문을 찾으십시오.

이 지시 사항을 보관하십시오.

Aviso INSTRUÇÕES IMPORTANTES DE SEGURANÇA

Este símbolo de aviso significa perigo. Você se encontra em uma situação em que há risco de lesões corporais. Antes de trabalhar com qualquer equipamento, esteja ciente dos riscos que envolvem os circuitos elétricos e familiarize-se com as práticas padrão de prevenção de acidentes. Use o número da declaração fornecido ao final de cada aviso para localizar sua tradução nos avisos de segurança traduzidos que acompanham o dispositivo.

GUARDE ESTAS INSTRUÇÕES

Advarsel VIGTIGE SIKKERHEDSANVISNINGER

Dette advarselssymbol betyder fare. Du befinder dig i en situation med risiko for legemeskadedigelse. Før du begynder arbejde på udstyr, skal du være opmærksom på de involverede risici, der er ved elektriske kredsløb, og du skal sætte dig ind i standardprocedurer til undgåelse af ulykker. Brug erklæringsnummeret efter hver advarsel for at finde oversættelsen i de oversatte advarsler, der fulgte med denne enhed.

GEM DISSE ANVISNINGER

تحذير

إرشادات الأمان الهامة

يوضح رمز التحذير هذا وجود خطر. وهذا يعني أنك متواجد في مكان قد ينتج عنه التعرض لإصابات. قبل بدء العمل، احذر مخاطر التعرض للصدمات الكهربائية وكن على علم بالإجراءات القياسية للحيلولة دون وقوع أي حوادث. استخدم رقم البيان الموجود في آخر كل تحذير لتحديد مكان ترجمته داخل تحذيرات الأمان المترجمة التي تأتي مع الجهاز. قم بحفظ هذه الإرشادات

Upozorenje VAŽNE SIGURNOSNE NAPOMENE

Ovaj simbol upozorenja predstavlja opasnost. Nalazite se u situaciji koja može prouzročiti tjelesne ozljede. Prije rada s bilo kojim uređajem, morate razumjeti opasnosti vezane uz električne sklopove, te biti upoznati sa standardnim načinima izbjegavanja nesreća. U prevedenim sigurnosnim upozorenjima, priloženima uz uređaj, možete prema broju koji se nalazi uz pojedino upozorenje pronaći i njegov prijevod.

SAČUVAJTE OVE UPUTE

Upozornění DŮLEŽITÉ BEZPEČNOSTNÍ POKYNY

Tento upozorňující symbol označuje nebezpečí. Jste v situaci, která by mohla způsobit nebezpečí úrazu. Před prací na jakémkoliv vybavení si uvědomte nebezpečí související s elektrickými obvody a seznamte se se standardními opatřeními pro předcházení úrazům. Podle čísla na konci každého upozornění vyhledejte jeho překlad v přeložených bezpečnostních upozorněních, která jsou přiložena k zařízení.

USCHOVEJTE TYTO POKYNY

Προειδοποίηση ΣΗΜΑΝΤΙΚΕΣ ΟΔΗΓΙΕΣ ΑΣΦΑΛΕΙΑΣ

Αυτό το προειδοποιητικό σύμβολο σημαίνει κίνδυνο. Βρίσκεστε σε κατάσταση που μπορεί να προκαλέσει τραυματισμό. Πριν εργαστείτε σε οποιοδήποτε εξοπλισμό, να έχετε υπόψη σας τους κινδύνους που σχετίζονται με τα ηλεκτρικά κυκλώματα και να έχετε εξοικειωθεί με τις συνήθειες πρακτικές για την αποφυγή ατυχημάτων. Χρησιμοποιήστε τον αριθμό δήλωσης που παρέχεται στο τέλος κάθε προειδοποίησης, για να εντοπίσετε τη μετάφρασή της στις μεταφρασμένες προειδοποιήσεις ασφαλείας που συνοδεύουν τη συσκευή.

ΦΥΛΑΞΤΕ ΑΥΤΕΣ ΤΙΣ ΟΔΗΓΙΕΣ

הרהר

וראות בטיחות חשובות:

ימן אזהרה זה מסמל סכנה. אתה נמצא במצב העלול לגרום לפציעה. לפני שתעבוד עם ציוד לשהו, עליך להיות מודע לסכנות הכרוכות במגעלים חשמליים ולהכיר את הנהלים המקובלים מניעת תאונות. השתמש במספר ההוראה המסופק בסופה של כל אזהרה כדי לאתר את התרגום. אזהרות הבטיחות המתורגמות שמצורפות להתקן.

מור הוראות אלה

Opomena

ВАЖНИ БЕЗБЕДНОСНИ НАПАТСТВИЈА

Симболот за предупредување значи опасност. Се наоѓате во ситуација што може да предизвика телесни повреди. Пред да работите со опремата, бидете свесни за ризикот што постои кај електричните кола и треба да ги познавате стандардните постапки за спречување на несреќни случаи. Искористете го бројот на изјавата што се наоѓа на крајот на секое предупредување за да го најдете неговиот период во преведените безбедносни предупредувања што се испорачани со уредот.

ЧУВАЈТЕ ГИ ОБИЕ НАПАТСТВИЈА

Ostrzeżenie

WAŻNE INSTRUKCJE DOTYCZĄCE BEZPIECZEŃSTWA

Ten symbol ostrzeżenia oznacza niebezpieczeństwo. Zachodzi sytuacja, która może powodować obrażenia ciała. Przed przystąpieniem do prac przy urządzeniach należy zapoznać się z zagrożeniami związanymi z układami elektrycznymi oraz ze standardowymi środkami zapobiegania wypadkom. Na końcu każdego ostrzeżenia podano numer, na podstawie którego można odszukać tłumaczenie tego ostrzeżenia w dołączonym do urządzenia dokumencie z tłumaczeniami ostrzeżeń.

NINIEJSZE INSTRUKCJE NALEŻY ZACHOWAĆ

Upozornenie

DÔLEŽITÉ BEZPEČNOSTNÉ POKYNY

Tento varovný symbol označuje nebezpečenstvo. Nachádzate sa v situácii s nebezpečenstvom úrazu. Pred prácou na akomkoľvek vybavení si uvedomte nebezpečenstvo súvisiace s elektrickými obvodmi a oboznámte sa so štandardnými opatreniami na predchádzanie úrazom. Podľa čísla na konci každého upozornenia vyhľadajte jeho preklad v preložených bezpečnostných upozorneniach, ktoré sú priložené k zariadeniu.

USCHOVAJTE SI TENTO NÁVOD



Warning

When installing the product, please use the provided or designated connection cables/power cables/AC adaptors. Using any other cables/adaptors could cause a malfunction or a fire. Electrical Appliance and Material Safety Law prohibits the use of UL-certified cables (that have the "UL" shown on the code) for any other electrical devices than products designated by CISCO. The use of cables that are certified by Electrical Appliance and Material Safety Law (that have "PSE" shown on the code) is not limited to CISCO-designated products. Statement 371.



Warning

There is the danger of explosion if the battery is replaced incorrectly. Replace the battery only with the same or equivalent type recommended by the manufacturer. Dispose of used batteries according to the manufacturer's instructions. Statement 1015



Warning

Do not use this product near water; for example, near a bath tub, wash bowl, kitchen sink or laundry tub, in a wet basement, or near a swimming pool. Statement 1035



Warning

Never install telephone jacks in wet locations unless the jack is specifically designed for wet locations. Statement 1036



Warning

Never touch uninsulated telephone wires or terminals unless the telephone line has been disconnected at the network interface. Statement 1037

Related Documentation

For a list of all related release and supported module documentation, see the *Documentation Roadmap for the Cisco ISR 4400 and Cisco ISR 4300 Series Integrated Services Routers* at the following URL:

<http://www.cisco.com/en/US/docs/routers/access/4400/roadmap/isr4400roadmap.html>

Searching for Cisco Documents

To search an HTML document using a web browser, press **Ctrl-F** (Windows) or **Cmd-F** (Apple). In most browsers, the option to search whole words only, invoke case sensitivity, or search forward and backward is also available.

To search a PDF document in Adobe Reader, use the basic Find toolbar (**Ctrl-F**) or the Full Reader Search window (**Shift-Ctrl-F**). Use the Find toolbar to find words or phrases within a specific document. Use the Full Reader Search window to search multiple PDF files simultaneously and to change case sensitivity and other options. The Adobe Reader online help has more information about how to search PDF documents.

Obtaining Documentation and Submitting a Service Request

For information on obtaining documentation, submitting a service request, and gathering additional information, see *What's New in Cisco Product Documentation* at:
<http://www.cisco.com/en/US/docs/general/whatsnew/whatsnew.html>.

Subscribe to *What's New in Cisco Product Documentation*, which lists all new and revised Cisco technical documentation, as an RSS feed and deliver content directly to your desktop using a reader application. The RSS feeds are a free service.



Overview of the Cisco 4000 Series ISR

This chapter contains the following sections:

- [About the Cisco 4000 Series ISR, page 1-1](#)
- [Safety Warnings, page 1-6](#)
- [Chassis Views, page 1-6](#)
- [Locating the Serial Number, PID, VID, and CLEI, page 1-25](#)
- [Hardware Features, page 1-26](#)
- [About Slots and Interfaces, page 1-39](#)
- [Specifications, page 1-42](#)
- [Periodic Inspection and Cleaning, page 1-51](#)

About the Cisco 4000 Series ISR

The Cisco 4000 Series Integrated Services Routers (ISRs) are modular routers with LAN and WAN connectivity. They support several interface modules, including Cisco Enhanced Service Modules (SM-X), and Cisco Network Interface Modules (NIMs).

The Cisco 4000 Series ISR target these applications:

- Enterprise applications—Intended as the mid-size aggregation and gateway router typically residing in a regional or large branch office:
 - WAN aggregation at Cisco Enterprise core
 - Internet gateway
 - Branch or regional office aggregation
 - Remote access aggregation
- Service provider applications—Intended for high-end Enterprise Branch environments:
 - High-end customer premises equipment (CPE) for business-quality Internet access
 - Service provider leased line aggregation
 - Provider edge (PE) and high-end customer edge (CE) for Layer 2 VPN or Layer 3 VPN services
 - Low-end Ethernet aggregation

The Cisco 4000 Series ISR are available in these models:

- Cisco 4451-X ISR
- Cisco 4431 ISR
- Cisco 4351ISR
- Cisco 4331ISR
- Cisco 4321 ISR
- Cisco 4221 ISR

The sections in this documentation apply to all platforms unless explicitly stated otherwise.

Cisco 4451-X ISR

The Cisco 4451-X ISR provides these capabilities:

- Two single-wide SM slots that can be converted into one double-wide SM slot.
- Three single-wide NIM slots that can be converted into one double-wide (NIM1 and NIM2) and one single wide NIM slot (NIM3).
- One 10/100/1000 RJ-45 Ethernet port for system management (labeled {GE 0} with {MGMT} on the left of the connector)
- Two USB Type A host ports
- One USB mini-Type B console (placed next to the RJ-45 console port)
- One RJ-45 console port
- One RJ-45 auxiliary port
- Four combo ports that can function as SFP or RJ-45 ports:
 - 4 10/100/1000 RJ-45 Ethernet ports (labeled GE 0/0/0, 0/0/1, 0/0/2, and 0/0/3)
 - 4 100/1000 SFP Ethernet ports (labeled SFP 0/0/0, 0/0/1, 0/0/2, and 0/0/3)
- LEDs for Ethernet and console status
- LED for the CompactFlash memory card
- Two DDR3-240 pin Control Plane DIMM (dual in-line memory module) slots supporting replaceable DIMM modules
- One DDR3-240 pin Forwarding Plane DIMM slot, which can be supporting replaceable DIMM modules
- One CompactFlash slot, which is serviceable when the fan tray is removed
- One internal 30-W PoE daughter card for two of the front Gigabit Ethernet ports (labeled GE 0/0/0 and 0/0/1)
- One available ISC slot for an optional serviceable daughter card high-density Packet Voice Digital Signal Processor Module (PVD4) to add IP voice and video capability
- Environment monitoring
- Field replaceable fan tray
- Dual redundant power supply units (PSUs)
- Support for dual 500-W PoE converter power supply module

Cisco 4431 ISR

The Cisco 4431 ISR provides these capabilities:

- 3 single-wide NIM slots that can be combined into one double-wide (NIM1 and NIM2) and one single-wide NIM.
- 10/100/1000 RJ-45 Ethernet port for system management (labeled GE mgmt)
- Two USB 2 Type A host ports
- One USB mini-Type B console (placed next to the RJ-45 console port)
- One RJ-45 console port
- One RJ-45 auxiliary port
- Four combo ports that can function as SFP or RJ-45 ports:
 - 4 10/100/1000 RJ-45 Ethernet ports (labeled GE 0/0/0, 0/0/1, 0/0/2, and 0/0/3)
 - 4 100/1000 SFP Ethernet ports (labeled SFP 0/0/0, 0/0/1, 0/0/2, and 0/0/3)
- LEDs for Ethernet and console status
- Two DDR3 240-pin Control Plane DIMM (dual in-line memory module) slots supporting replaceable DIMM modules
- One DDR3 240-pin Forwarding Plane DIMM slot supporting replaceable DIMM modules
- One eUSB flash slot, which is serviceable
- One internal 30-W PoE daughter card for two of the front Gigabit Ethernet ports (labeled GE 0/0/0 and 0/0/1)
- One available ISC slot for an optional serviceable daughter card high-density Packet Voice Digital Signal Processor Module (PVDM4) to add IP voice and video capability
- Environment monitoring
- Field replaceable fan tray
- Dual redundant power supply units (PSUs)
- Support for dual 500-W AC+PoE power supply units

Cisco 4351 ISR

The Cisco 4351ISR provides these capabilities:

- Two single-wide SM slots that can be converted into one double-wide SM slot.
- Three single-wide NIM slots that can converted into one double-wide (NIM1 and NIM2) and one single-wide NIM slot (NIM3).
- One 10/100/1000 RJ-45 Ethernet port for system management (labeled {GE 0} with {MGMT} on the left of the connector)
- Two USB Type A host ports
- One USB mini-Type B console (placed next to the RJ-45 console port)
- One RJ-45 console port
- One RJ-45 auxiliary port

- Three combo ports that can function as SFP or RJ-45 ports:
 - 3 10/100/1000 RJ-45 Ethernet ports (labeled GE 0/0/0, 0/0/1, and 0/0/2)
 - 3 100/1000 SFP Ethernet ports (labeled SFP 0/0/0, 0/0/1, and 0/0/2)
- One optional internal SSD mSATA storage device
- LEDs for Ethernet and console status
- LED for SSD status
- Two DDR3 DIMM slots supporting replaceable DIMM modules
- One eUSB flash slot, which is serviceable
- One serviceable internal 30-W PoE daughter card for two of the front Gigabit Ethernet ports (labeled GE 0/0/0 and 0/0/1)
- One available ISC slot for an optional serviceable daughter card PVDM4 module to add IP voice and video capability
- Environment monitoring
- Field replaceable fan tray
- Single PSU
- Support for a single 500-W PoE converter power supply module

Cisco 4331 ISR

The Cisco 4331 ISR provides these capabilities:

- One single-wide SM slot
- Two single-wide NIM slots that can combined into one double-wide (NIM1 and NIM2).
- One 10/100/1000 RJ-45 Ethernet port for system management (labeled {MGMT} on the right of the connector)
- One USB Type A host port
- One USB mini-Type B console (placed next to the RJ-45 console port)
- One RJ-45 console port
- One RJ-45 auxiliary port
- Three GE ports allocated among two RJ45 and two SFP as:
 - One combo port with 10/100/1000 RJ-45 Ethernet port or SFP Ethernet port (labeled GE0/0/0)
 - One dedicated 10/100/1000 RJ-45 Ethernet port (labeled GE0/0/1)
 - One dedicated SFP Ethernet port (labeled GE0/0/2)
- Optional internal SSD mSATA storage device
- LEDs for Ethernet and console status
- LED for SSD status
- Two DDR3 DIMMs slots supporting replaceable DIMM modules
- One eUSB flash slot, which is serviceable

- One available ISC slot for an optional serviceable daughter card PVDM4 module to add IP Voice and video capability
- Environment monitoring

Cisco 4321 ISR

The Cisco 4321 ISR provides these capabilities:

- Two single-wide NIM slots that can be converted into one double-wide (NIM1 and NIM2).
- One 10/100/1000 RJ-45 Ethernet port for system management (labeled {MGMT} on the right of the connector)
- One USB Type A host port
- One USB mini-Type B console (placed next to the RJ-45 console port)
- One RJ-45 console port
- One RJ-45 auxiliary port
- Two GE ports allocated among two RJ45 and one SFP as:
 - One combo port with 10/100/1000 RJ-45 Ethernet port or SFP Ethernet port (labeled GE0/0/0)
 - One dedicated 10/100/1000 RJ-45 Ethernet port (labeled GE0/0/1)
- Optional internal SSD mSATA storage device
- LEDs for Ethernet and console status
- LED for SSD
- One DDR3 DIMMs slot supporting replaceable DIMM modules
- One eUSB flash slot, which is serviceable
- One available ISC slot for an optional serviceable daughter card PVDM4 module to add IP voice and video capability
- Environment monitoring

Cisco 4221 ISR

The Cisco 4221 ISR provides these capabilities:

- Two single-wide NIM slots
- One USB Type A host port
- One RJ-45 shared console port and auxiliary port
- Two GE ports allocated among RJ45 and SFP as:
 - One combo port with 10/100/1000 RJ-45 Ethernet port or SFP Ethernet port (labeled GE0/0/0)
 - One dedicated 10/100/1000 RJ-45 Ethernet port (labeled GE0/0/1)
- LEDs for Ethernet and console status
- Environment monitoring

Safety Warnings



Warning

IMPORTANT SAFETY INSTRUCTIONS

This warning symbol means danger. You are in a situation that could cause bodily injury. Before you work on any equipment, be aware of the hazards involved with electrical circuitry and be familiar with standard practices for preventing accidents. Use the statement number provided at the end of each warning to locate its translation in the translated safety warnings that accompanied this device.
Statement 1071

SAVE THESE INSTRUCTIONS



Warning

Ultimate disposal of this product should be handled according to all national laws and regulations.
Statement 1040



Warning

Only trained and qualified personnel should be allowed to install, replace, or service this equipment.
Statement 1030

Safety Warnings for Finland, Norway, and Sweden

Warning statement 1017 applies to the countries of Finland, Norway, and Sweden.



Warning

This unit is intended for installation in restricted access areas. A restricted access area can be accessed only through the use of a special tool, lock and key, or other means of security.
Statement 1017

Chassis Views

This section contains views of the front and back panels of the Cisco 4000 Series ISR, showing locations of the power and signal interfaces, module slots, status indicators, and chassis identification labels:

- [Cisco 4451-X ISR Chassis](#)
- [Cisco 4431 ISR Chassis](#)
- [Cisco 4351 ISR Chassis](#)
- [Cisco 4331 ISR Chassis](#)
- [Cisco 4321 ISR Chassis](#)
- [Cisco 4221 ISR Chassis](#)

Cisco 4451-X ISR Chassis

Note

The Cisco 4451-X ISR routers support these slot types:

- Network Interface Modules (NIMs)
- Service modules (SM-X, like SM-X-1T3/E3)
- E-Series Server Modules

[Figure 1-1 on page 1-7](#)—Bezel view with two PSUs

[Figure 1-2 on page 1-8](#)—Back panel slots and ports

[Figure 1-3 on page 1-9](#)—Bezel side LEDs

Figure 1-1 Bezel Side of the Cisco 4451-X ISR with Two PSUs

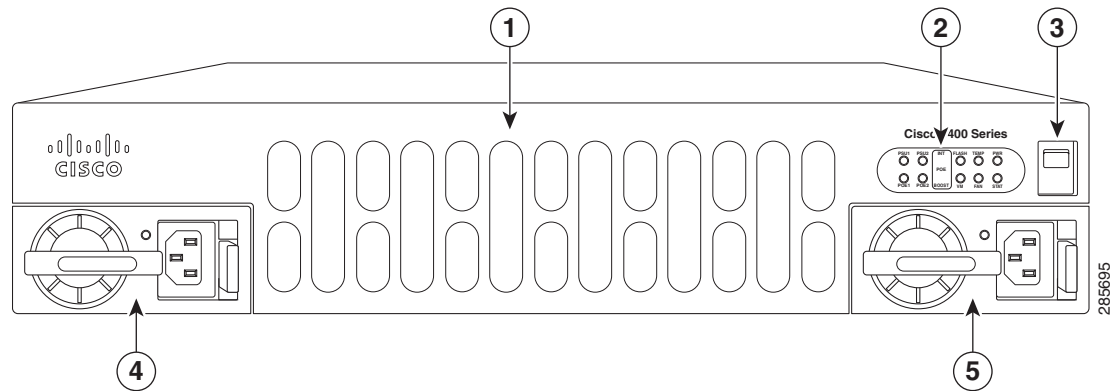

1	Router fan tray (hidden) behind removable bezel	2	LEDs
3	Router power On/Off switch	4	AC power supply unit (PSU0)
5	AC power supply unit (PSU1)		

Figure 1-2 Back Panel (I/O Side) Slots and Connectors on the Cisco 4451-X ISR

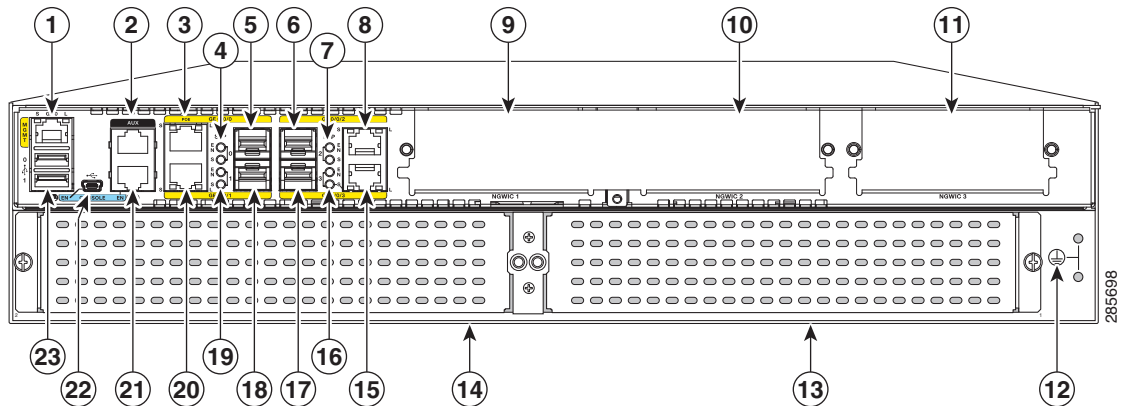

1	GE 0 management port	2	Auxiliary port
3	RJ-45 Gigabit Ethernet port (GE 0/0/0)	4	LEDs for the GE 0/0/0 interface (See Table 1-1 for detailed LED information)
5	SFP/Gigabit Ethernet port (GE 0/0/0)	6	SFP/Gigabit Ethernet port (GE 0/0/2)
7	LEDs for the GE 0/0/2 interface	8	RJ-45 Gigabit Ethernet port (GE 0/0/2)
9	NIM slot 1 (shown with slot divider removed).	10	NIM slot 2 (shown with slot divider removed).
11	NIM slot 3	12	Ground connection
13	Enhanced Service Module (SM-X) 2	14	Enhanced Service Module (SM-X) 1
15	RJ-45 Gigabit Ethernet port GE 0/0/3	16	LEDs for the GE 0/0/3 interface
17	SFP/Gigabit Ethernet GE 0/0/3	18	SFP Gigabit Ethernet GE 0/0/1
19	LEDs for the GE 0/0/1 interface	20	RJ-45 Gigabit Ethernet port GE 0/0/1
21	Serial console port	22	USB Type B mini port
23	USB 0 and USB 1		

Figure 1-3 Bezel Side LEDs of the Cisco 4451-X ISR Model

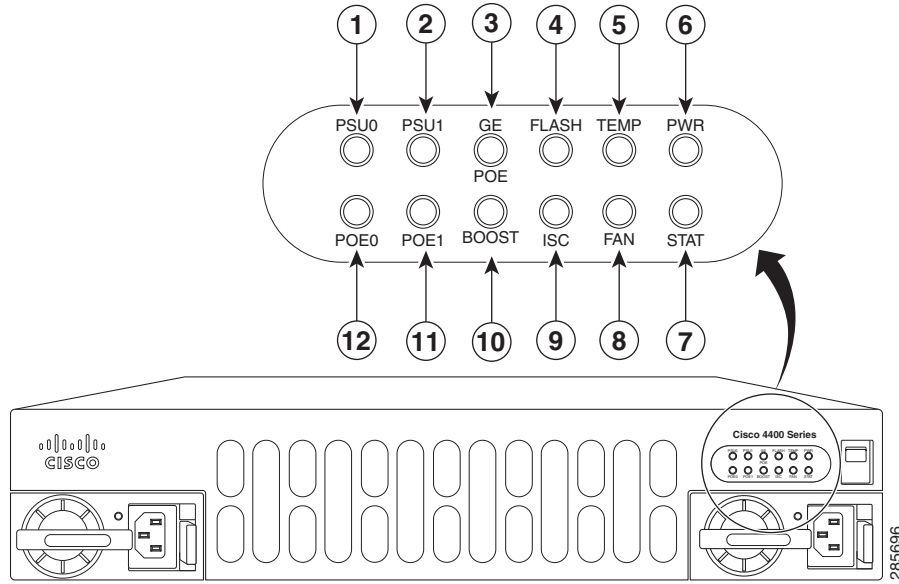

1	PSU0: Power supply unit 1	2	PSU1: Power supply unit 2
3	GE POE: Internal PoE daughter card status	4	FLASH: Compact flash status
5	TEMP: Temperature status	6	PWR: Power
7	STAT: System status	8	FAN: Fan status
9	ISC: Integrated Services Card status	10	POE BOOST: Power over Ethernet boost mode
11	POE 1: Power over Ethernet 1 status	12	POE 0: Power over Ethernet 0 status

Platform Summary

Figure 1-4 shows an internal view of the Cisco 4451-X ISR with the parts and module locations.

Figure 1-4 Platform Summary of the Cisco 4451-X ISR

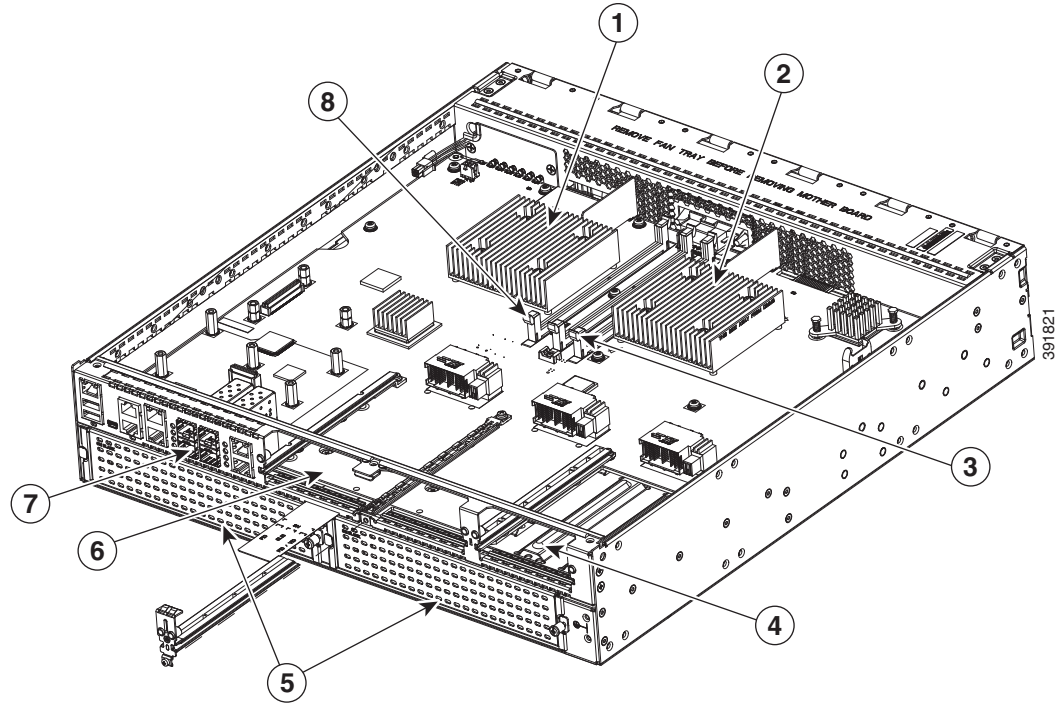

1	Forwarding plane processor	2	Control plane processor
3	Control plane processor DIMMs	4	NIM 3 (single-wide) slot
5	Enhanced Service Module (SM-X) slots	6	NIM slot 1 and 2 (shown with slot divider removed)
7	SFP GE ports	8	Forwarding plane processor DIMM

Cisco 4431 ISR Chassis



Note

The Cisco 4431 ISR support the following slot types:

- Network Interface Modules (NIMs)
- Integrated Services Card (ISC slots for PVDM4s)

Figure 1-5 on page 1-11—Bezel view with two PSUs

Figure 1-6 on page 1-12—View of the chassis

Figure 1-7 on page 1-12—Bezel side LEDs

Figure 1-5 Bezel View of the Cisco 4431 ISR with Two Power Supply Units

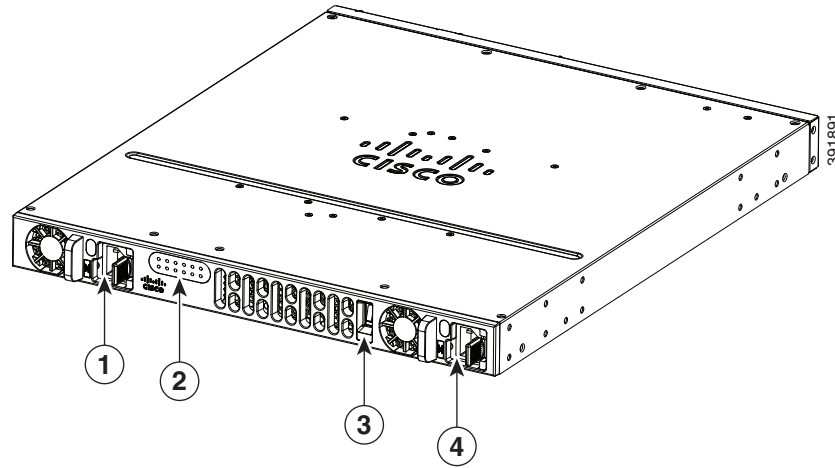

1	Power supply unit	2	LEDs
3	On/Off switch	4	Optional power supply unit

Figure 1-6 View of the Cisco 4431 ISR Chassis

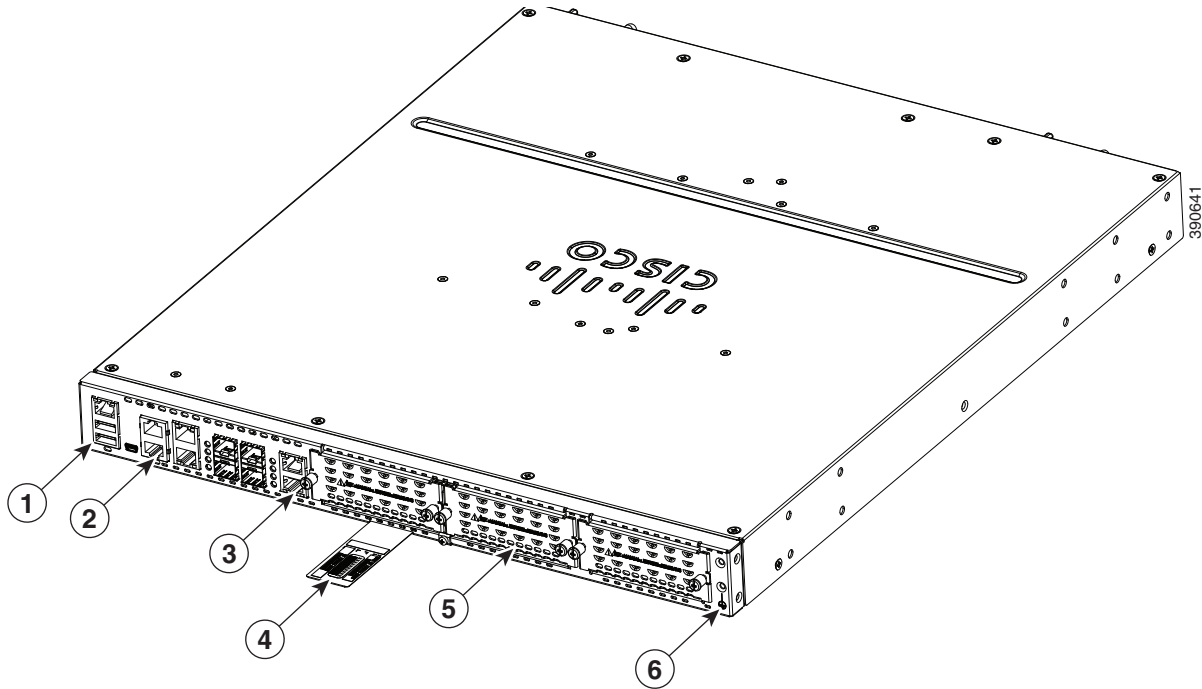

1	USB ports	2	GE ports
3	Screws to open the NIM slot	4	Router label tray
5	NIM slot (with cover)	6	Ground connection

Figure 1-7 LEDs on the Cisco 4431 ISR

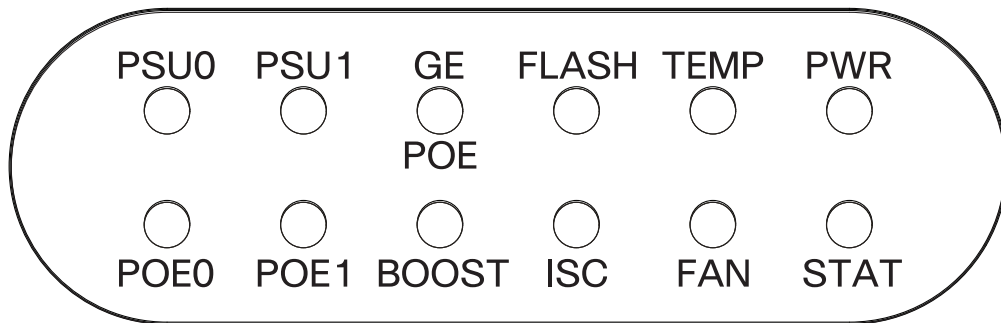

For detailed information on LEDs, see the [“LED Indicators”](#) section on page 1-28.

Platform Summary

Figure 1-4 shows an internal view of the Cisco 4431 ISR with the parts and module locations.

Figure 1-8 Platform Summary of the Cisco 4431 ISR

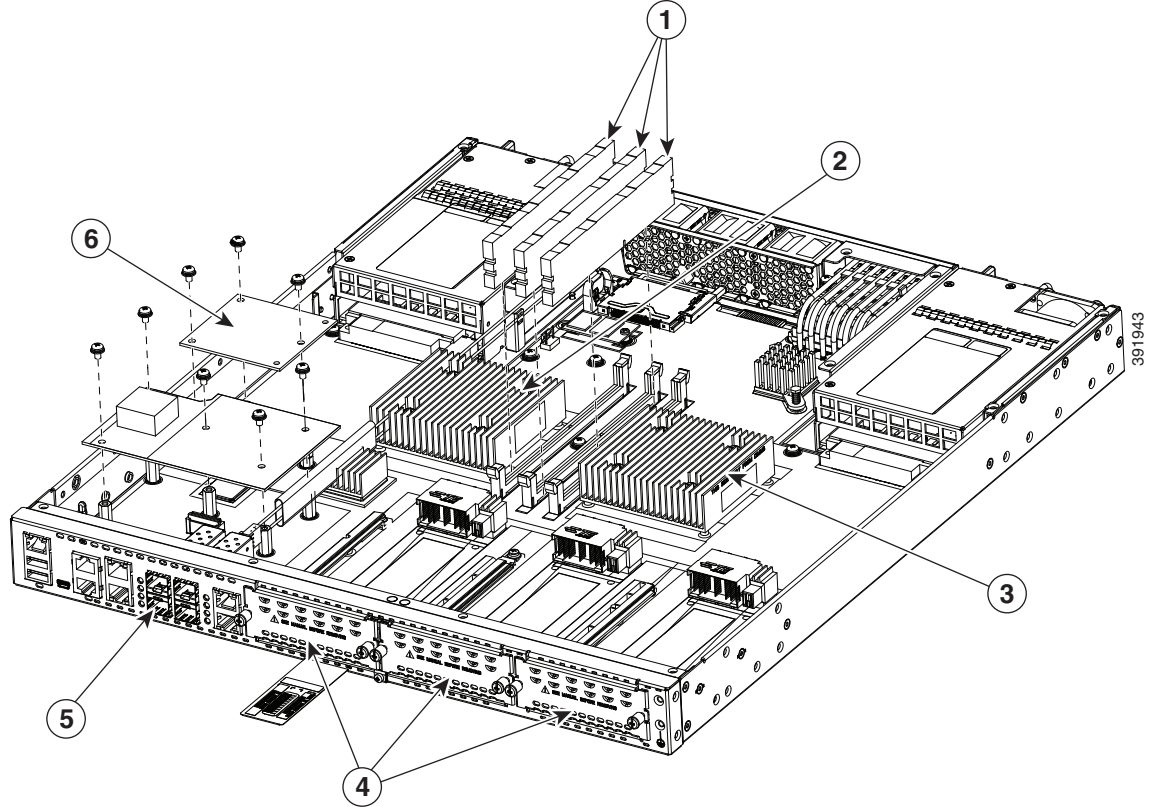

1	DIMMs	2	Forwarding plane processor
3	Control plane processor	4	NIMs
5	SFP GE ports	6	PVDM card

Cisco 4351 ISR Chassis

This section contains the following views of the Cisco 4351ISR chassis:

- [Power Supply and Bezel Side View of the Cisco 4351 ISR \(Figure 1-9\)](#)
- [Back Panel Ports, Slots, and Serial Number on the Cisco 4351 ISR \(Figure 1-10\)](#)
- [Ports on the Cisco 4351 ISR \(Figure 1-11\)](#)
- [LEDs on the Cisco 4351 ISR \(Figure 1-12\)](#)

Figure 1-9 Power Supply and Bezel Side View of the Cisco 4351 ISR

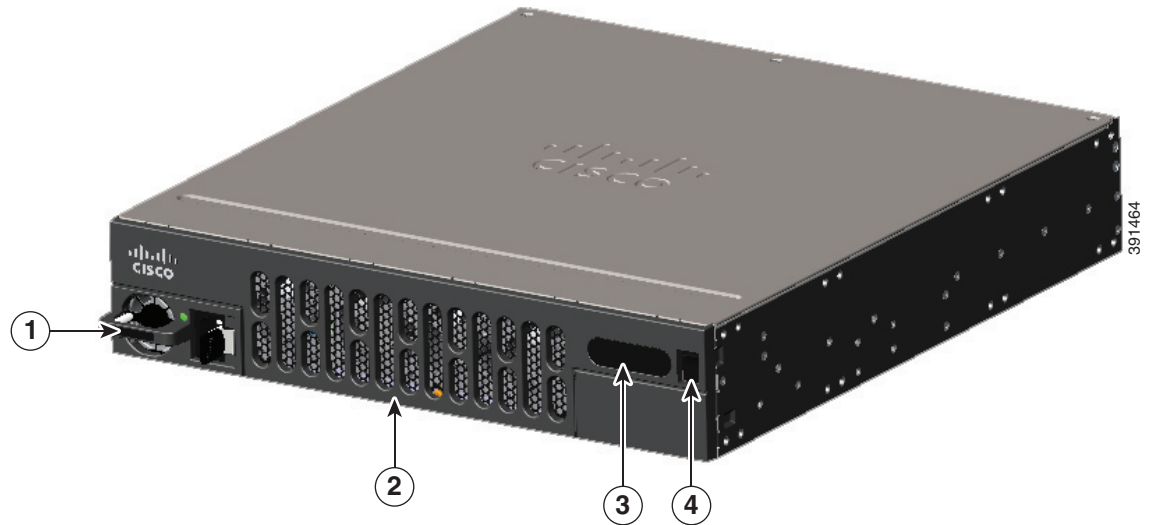

1	Power supply unit	2	Router fan tray (hidden behind the removable bezel)
3	LEDs	4	Router power On/Off switch

Figure 1-10 Back Panel Ports, Slots, and Serial Number on the Cisco 4351 ISR

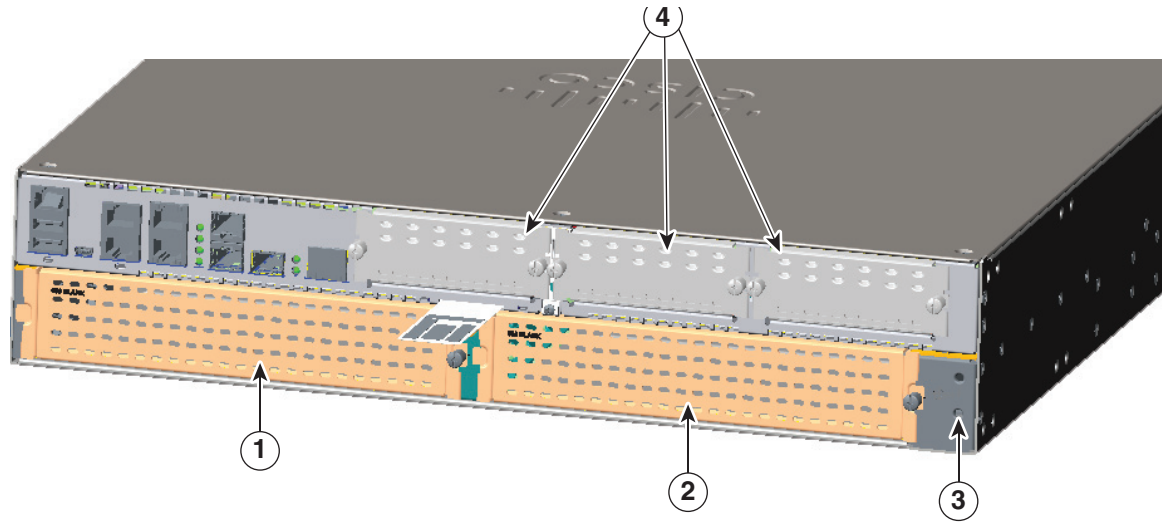

1	Enhanced Service Module (SM-X) slot	2	Enhanced Service Module (SM-X) slot
3	Ground connection	4	NIM slots

Figure 1-11 Ports on the Cisco 4351 ISR

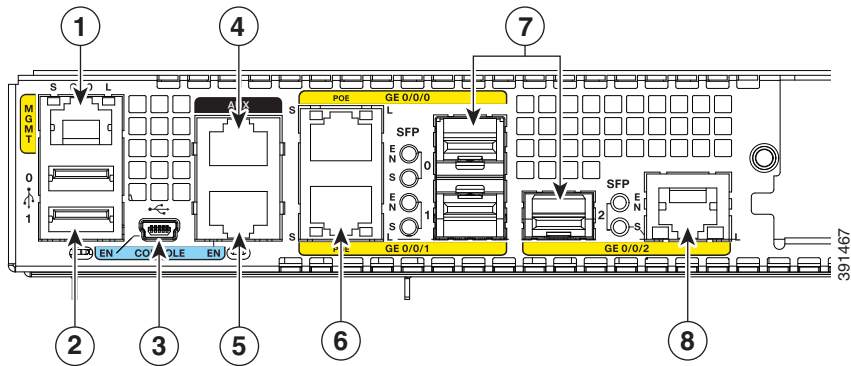

1	GE management port	2	USB Type A port
3	USB Type B mini port	4	Auxiliary port
5	Console port	6	RJ-45 port (GE 0/0/1)
7	SFP port (GE 0/0/0)	8	RJ-45 port (GE/0/0/2)

Figure 1-12 LEDs on the Cisco 4351 ISR

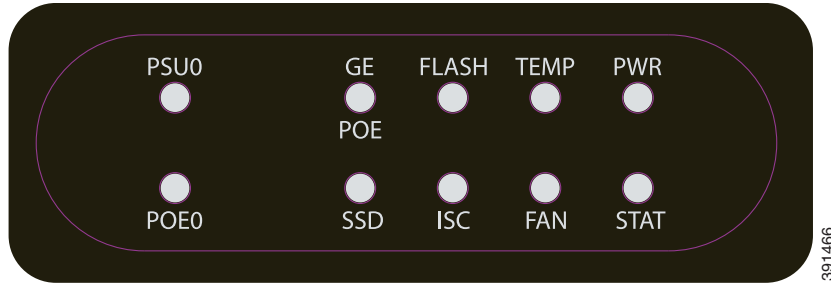

For detailed information on LEDs, see the “LED Indicators” section on page 1-28.

Platform Summary

Figure 1-4 shows an internal view of the Cisco 4351 ISR chassis with the parts and module locations.

Figure 1-13 Platform Summary of the Cisco 4351 ISR Chassis

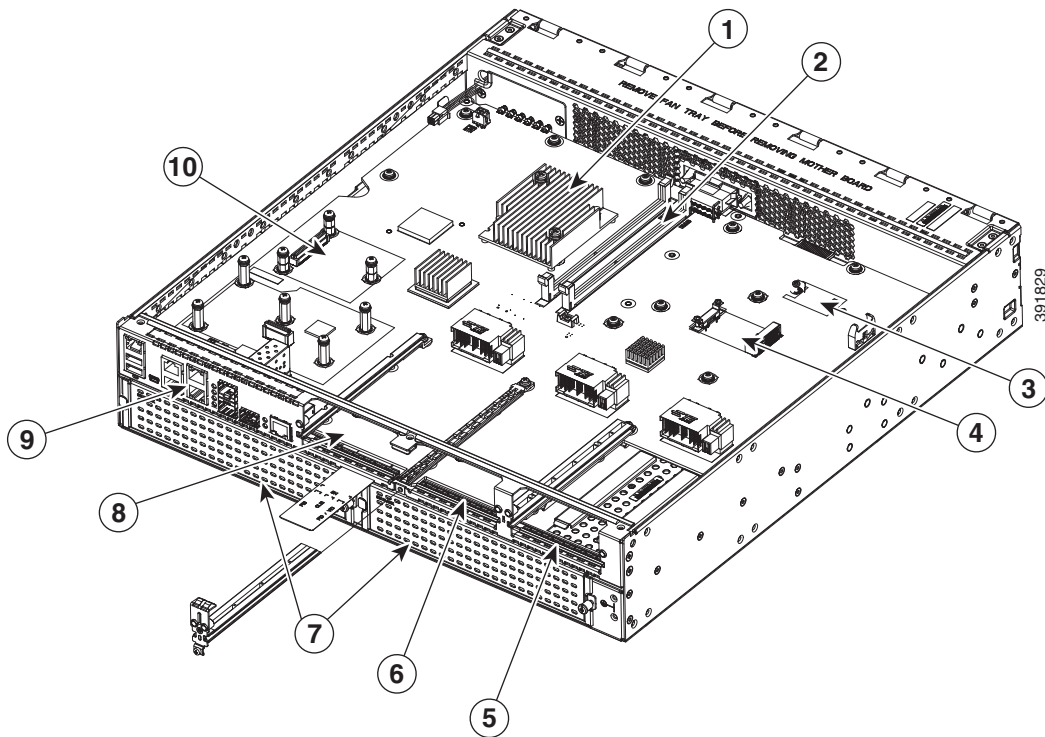

1	CPU	2	DIMMs
3	Flash memory card connector	4	SSD mSATA connector
5	NIM slot 3	6	NIM slot 2
7	SM-X slots	8	NIM slot 1
9	RJ-45 GE ports	10	ISC slot

Cisco 4331 ISR Chassis

This section contains the following views of the Cisco 4331 ISR router:

- [Bezel Side Ports and LEDs on the Cisco 4331 ISR \(Figure 1-14\)](#)
- [Back Panel Ports and Slots on the Cisco 4331 ISR \(Figure 1-15\)](#)

Figure 1-14 Bezel Side Ports and LEDs on the Cisco 4331 ISR

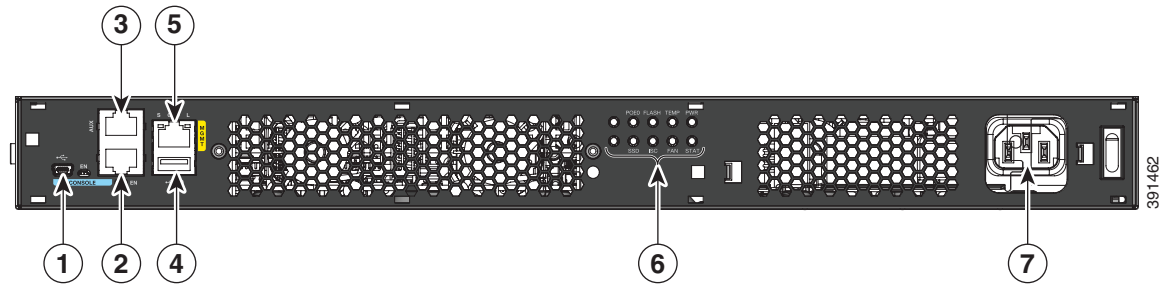

1	USB Type B mini port	2	Serial console port
3	AUX port	4	USB Type A port
5	Management port	6	LEDs
7	AC Power		

Figure 1-15 Back Panel Ports and Slots on the Cisco 4331 ISR

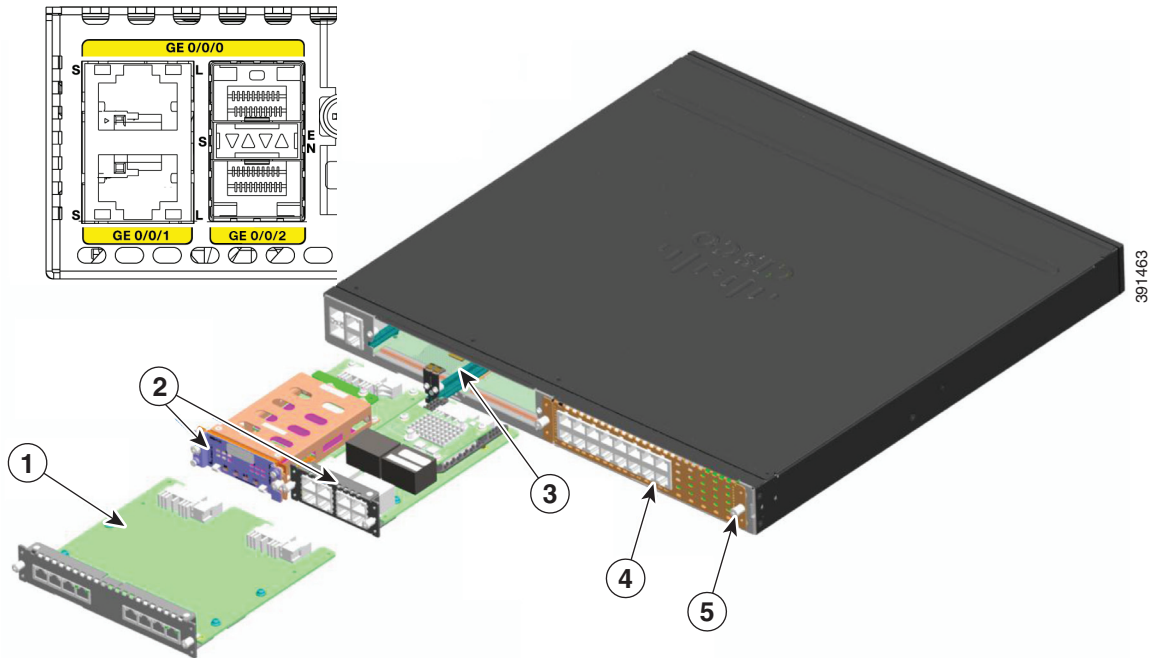

1	Double-wide NIM	2	NIMs
3	Removable module slot divider	4	SM-X slot
5	Ground connection		

For detailed information on LEDs, see the “LED Indicators” section on page 1-28.

Platform Summary

Figure 1-16 shows an internal view of the Cisco 4431 ISR with the parts and module locations.

Figure 1-16 Platform Summary of the Cisco 4331 ISR Chassis

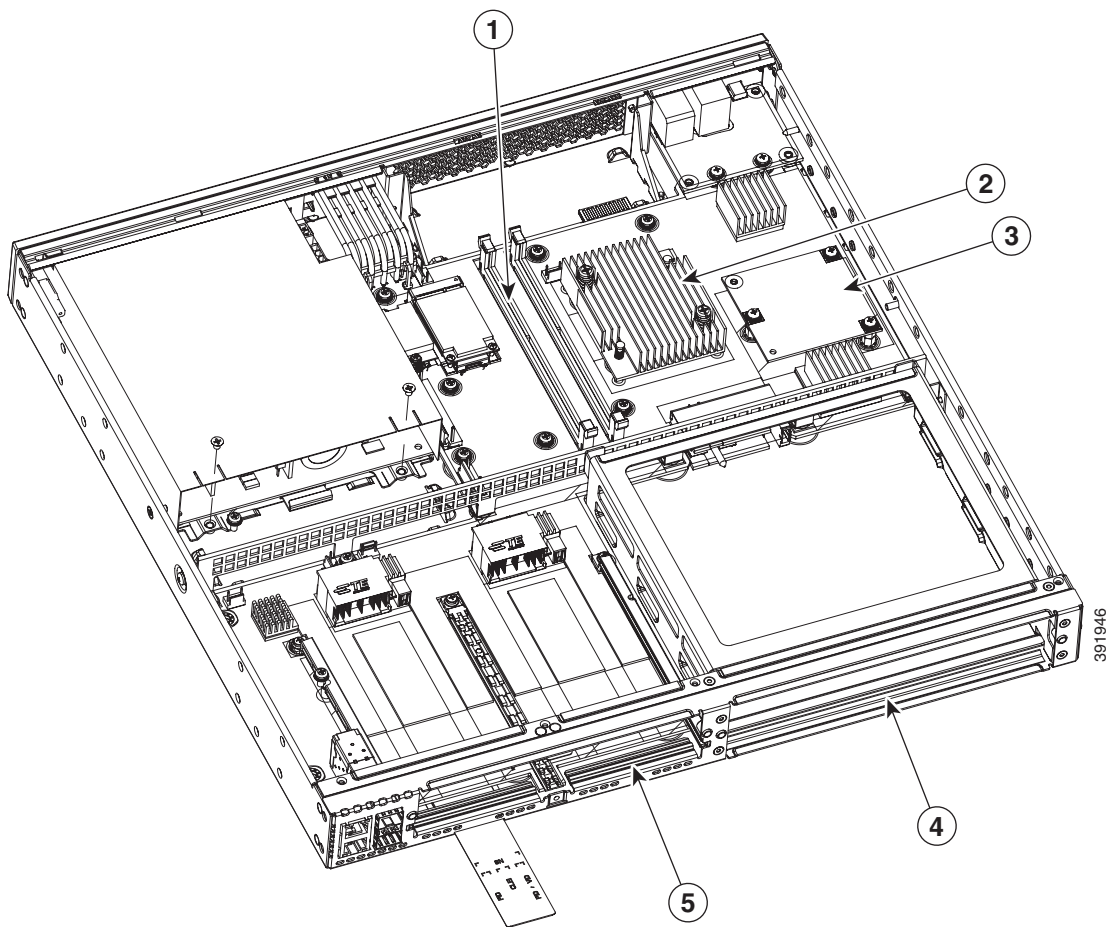

1	DIMMs	2	CPU
3	ISC slot	4	SM-X slot
5	NIM slot		

Cisco 4321 ISR Chassis

This section contains the following views of the Cisco 4321 ISR router:

- [Back Panel Ports on the Cisco 4321 ISR](#)
- [LEDs on the Cisco 4321 ISR \(Figure 1-17\)](#)
- [LEDs on the Cisco 4321 ISR \(Figure 1-18\)](#)

Figure 1-17 Back Panel Ports on the Cisco 4321 ISR

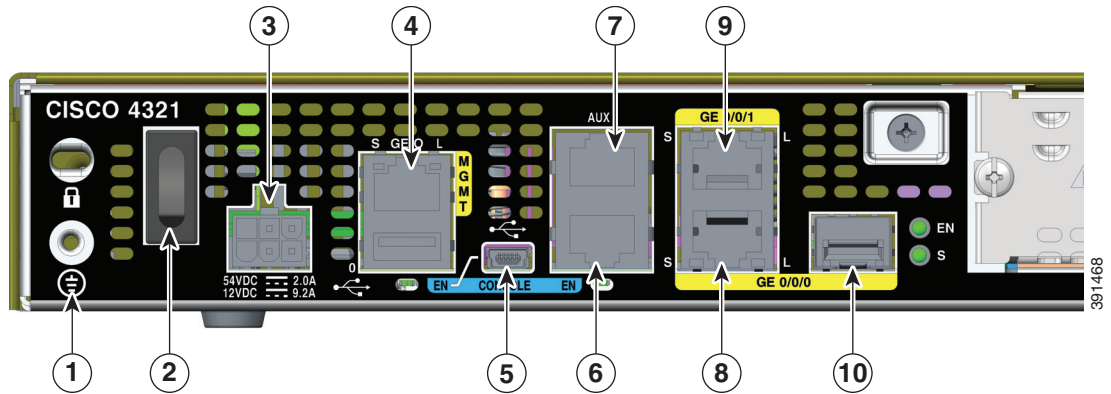

1	Grounding	2	Power switch
3	Power input connector	4	GE “MGMT” port (with USB port below)
5	USB Type B mini port	6	Console port
7	Auxiliary port	8	GE 0/0/1 (copper cable) port
9	GE 0/0/0 RJ-45 (copper cable) port	10	GE 0/0/0 SFP (fiber-optic) port

Figure 1-18 Back Panel (I/O Side) View of the Cisco 4321 ISR

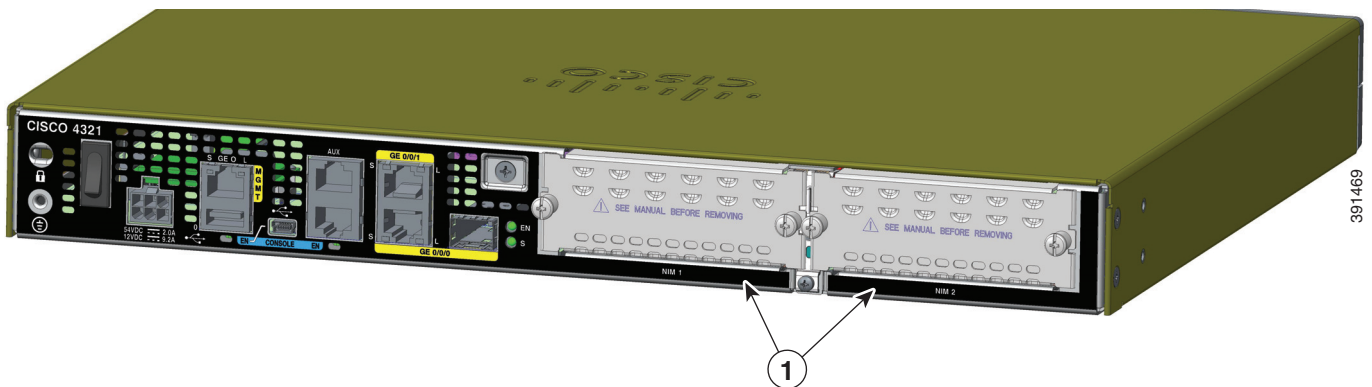

1	NIM slots
---	-----------

Figure 1-19 LEDs on the Cisco 4321 ISR

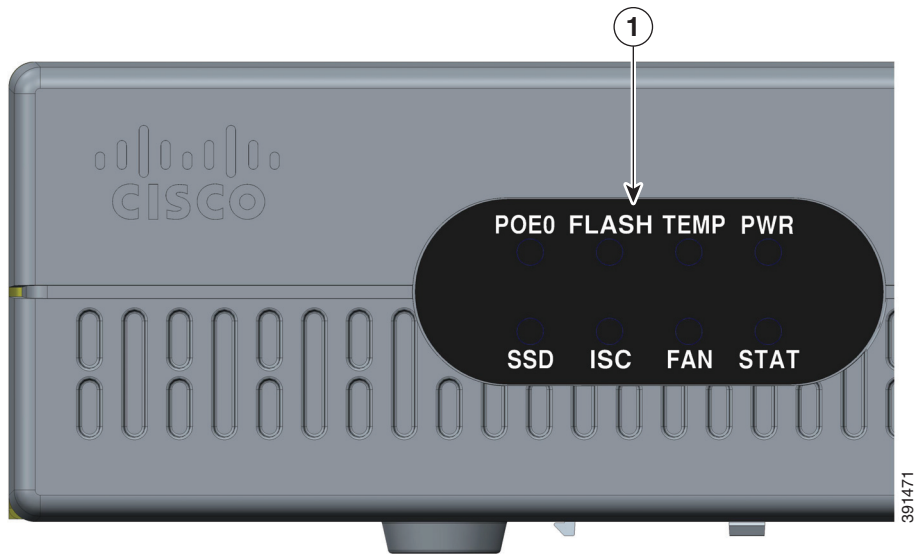

1	LEDs
----------	------

For detailed information on LEDs, see the [“LED Indicators”](#) section on page 1-28.

Platform Summary

Figure 1-20 shows an internal view of the Cisco 4321 ISR with the parts and module locations.

Figure 1-20 Platform Summary of the Cisco 4321 ISR Chassis

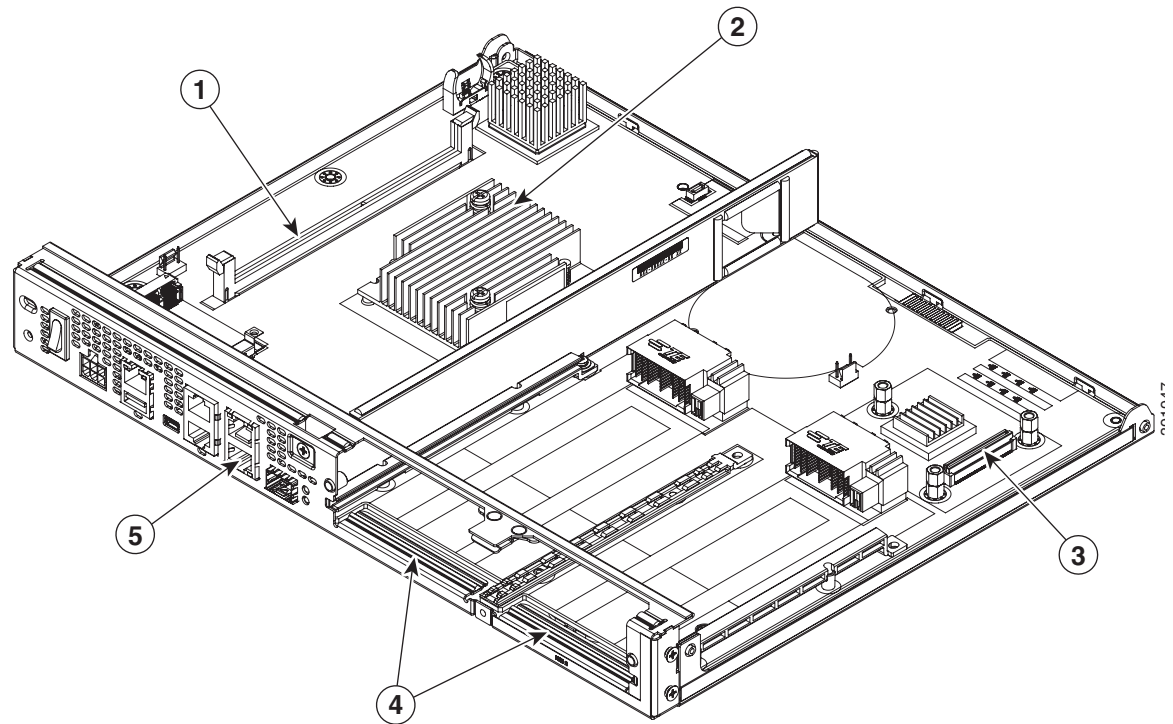

1	DIMM	2	CPU
3	ISC slot	4	NIM slots
5	GE ports		

Cisco 4221 ISR Chassis

This section contains the following views of the Cisco 4221 ISR router:

- [Back Panel Ports on the Cisco 4221 ISR \(Figure 1-21\)](#)
- [Back Panel \(I/O Side\) View of the Cisco 4221 ISR \(Figure 1-22\)](#)
- [LEDs on the Cisco 4221 ISR \(Figure 1-23\)](#)

Figure 1-21 Back Panel Ports on the Cisco 4221 ISR

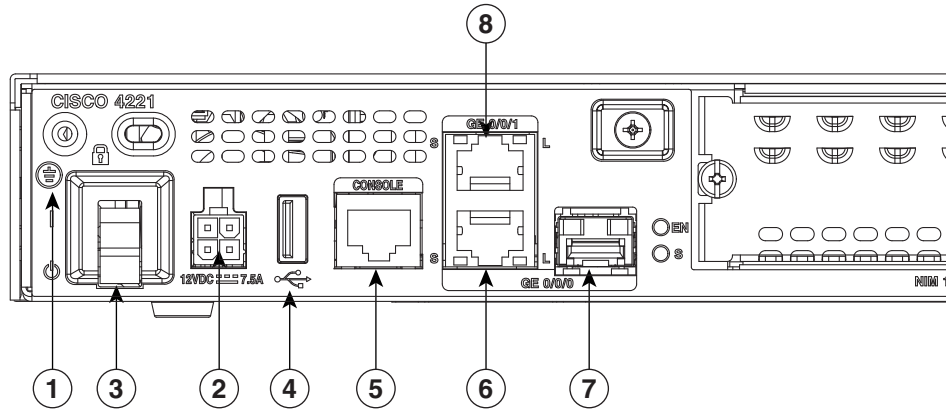

365769

1	Grounding	2	Power input connector
3	Power switch	4	USB
5	Console port	6	GE 0/0/0 RJ-45 (copper cable) port
7	GE 0/0/0 SFP (fiber-optic) port	8	GE 0/0/1 (copper cable) port

Figure 1-22 Back Panel (I/O Side) View of the Cisco 4221 ISR

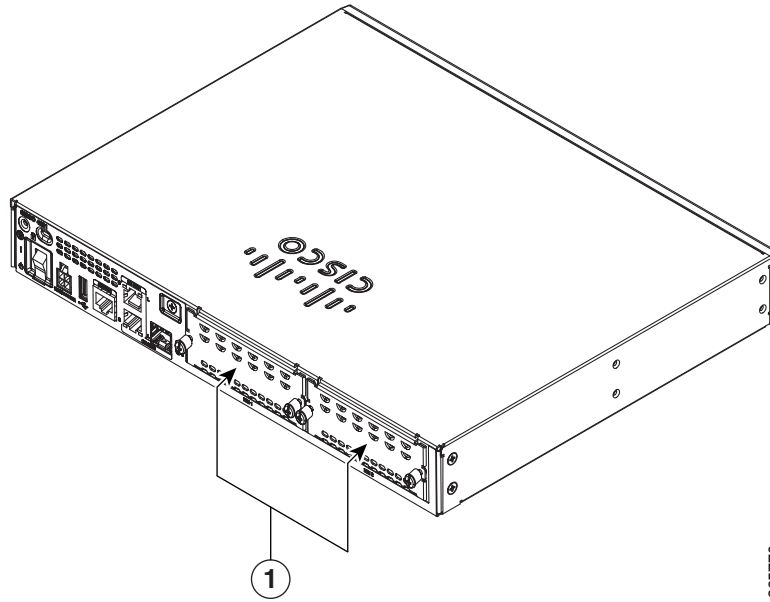

365770

1	NIM slots
---	-----------

Figure 1-23 LEDs on the Cisco 4221 ISR

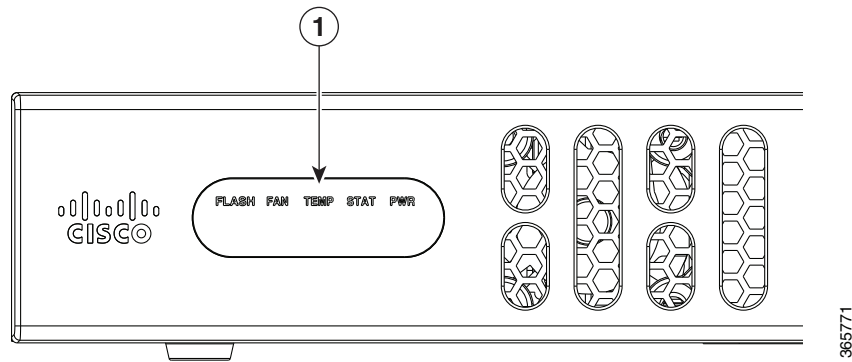

1	LEDs
----------	------

For detailed information on LEDs, see the [“LED Indicators”](#) section on page 1-28.

Platform Summary

Figure 1-24 shows an internal view of the Cisco 4221 ISR with the parts and module locations.

Figure 1-24 Platform Summary of the Cisco 4221 ISR Chassis

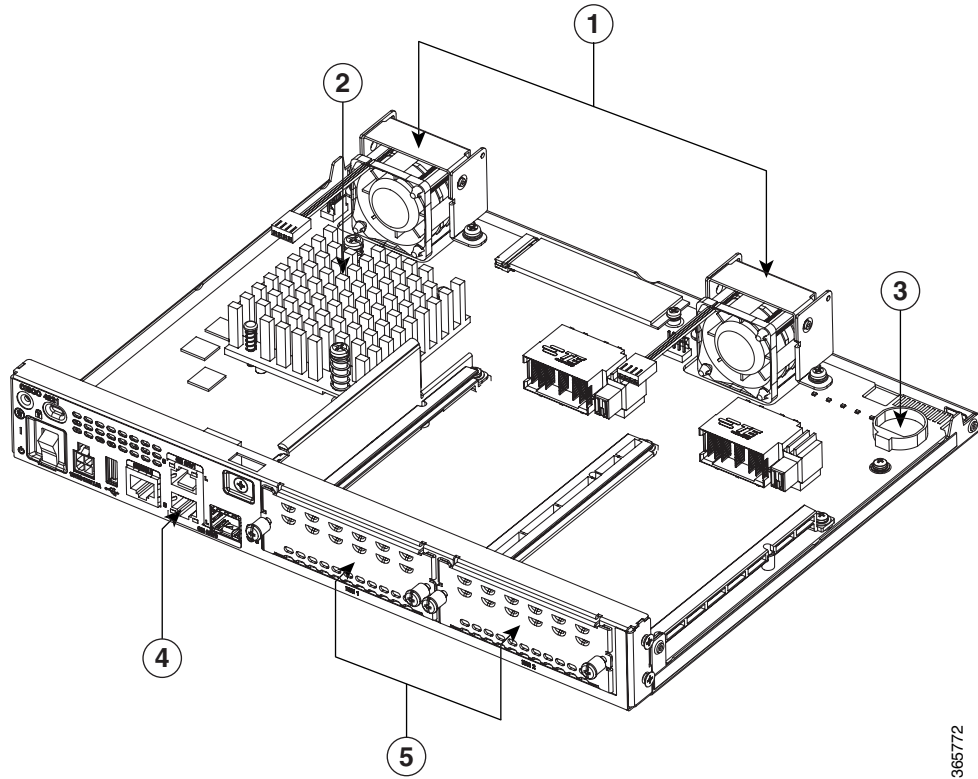

365772

1	Fan	2	CPU
3	Battery	4	GE 0/0/0/0 RJ-45 (copper cable) port
5	NIM slots		

Hardware and Module Configuration

Table 1-1 shows the key hardware and module configurations in the Cisco 4000 Series ISRs.

Table 1-1 Hardware Features and Module Configuration in the Cisco 4000 Series ISRs

Interface	Cisco 4451-X ISR	Cisco 4431 ISR	Cisco 4351 ISR	Cisco 4331 ISR	Cisco 4321 ISR	Cisco 4221 ISR
DRAM	3 DIMMs 2 GB for each slot	3 DIMMs 2 GB for each slot	2 DIMMs 2 GB for each slot	2 DIMMs 2 GB for each slot	1 DIMM (4 GB DIMM supported) ¹ 4 GB on board memory	4 Gb on board memory
NIMs	3 single-wide or 1 double-wide + 1 single-wide	3 single-wide or 1 double-wide + 1 single-wide	3 single-wide or 1 double-wide + 1 single-wide	2 single-wide or 1 double-wide	2 single-wide or 1 double-wide	2 single-wide NIM slots or 1 double-wide
SM-X	2 single-wide or 1 double-wide	NA	2 single-wide or 1 double-wide	1 single-wide	NA	NA
SSD or HDD NIM	1 single-wide	1 single-wide	1 single-wide	1 single-wide	1 single-wide	1 single-wide
Internal mSATA Interface	NA	NA	1 mSATA slot	1 mSATA slot	1 mSATA slot	NA
Front Panel PoE	2 PoE ports	2 PoE ports	2 PoE ports	NA	NA	NA
Front Panel GE	4 ports	4 ports	3 ports	3 ports	2 ports	2 ports
ISC Slot	All ISC card types	All ISC card types	All ISC card types	All ISC card types	All ISC card types	NA
USB Type A Ports	2 USB Type A	2 USB Type A	2 USB Type A	1 USB Type A	1 USB Type A	1 USB Type A

1. There is no DIMM installed by default. DIMM is optional.

Locating the Serial Number, PID, VID, and CLEI

Software License

To obtain a software license, you need a product authorization key (PAK) and the unique device identifier (UDI) of the device where the license will be installed.

The serial number (SN), product ID (PID), version ID (VID), and Common Language Equipment Identifier (CLEI) are printed on a label on the back of the router or on a label tray located on the router chassis or motherboard. The UDI can be viewed using the **show license udi** command in privileged Exec mode in Cisco Internet Operating System (IOS) software. For additional information on the UDI or how to obtain a PAK, see the [Cisco Software Activation on Integrated Services Routers and Cisco Integrated Service Routers Generation 2](#) document on Cisco.com.

The UDI has two main components:

- Product ID (PID)
- Serial number (SN)

Labels on the Router

Though your router might be different from the one shown in [Figure 1-25](#), the label location is similar for all routers in the Cisco 4000 Series ISR. [Figure 1-25](#) shows the location of the labels on the Cisco 4451-X ISRs.

Figure 1-25 Label Location on the Cisco 4451-X ISR

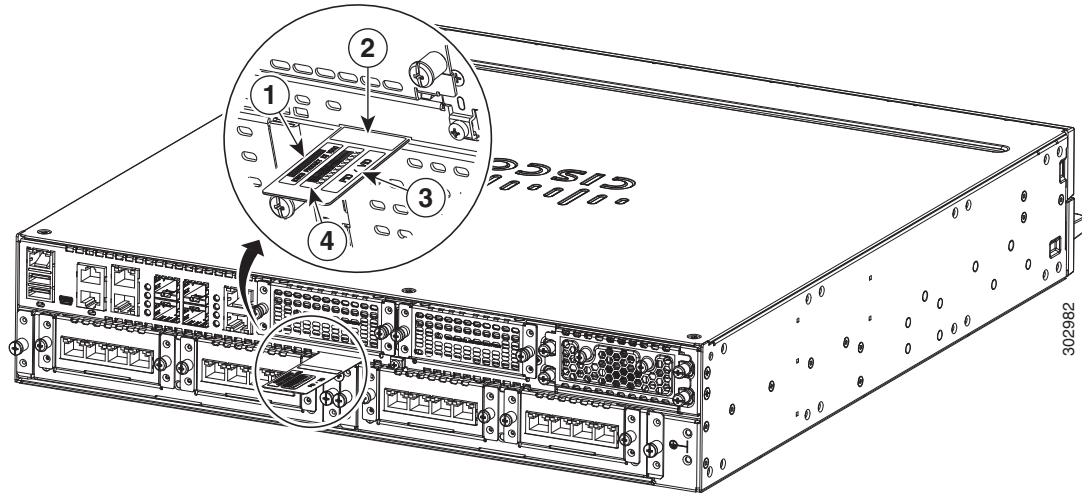

1	Product ID	2	Serial Number
3	PID/VID	4	CLEI

For Additional Help Locating Labels on the Router

Use the Cisco Product Identification (CPI) tool to find labels on the router. The tool provides detailed illustrations and descriptions of where the labels are located on Cisco products. It includes the following features:

- A search option that allows browsing for models by using a tree-structured product hierarchy
- A search field on the final results page that makes it easier to look up multiple products
- End-of-sale products clearly identified in results lists

The tool streamlines the process of locating serial number labels and identifying products. Serial number information expedites the entitlement process and is important for access to support services.

Hardware Features

This section describes the hardware features in the routers.

- [Built-In Interface Ports](#), page 1-27
- [LED Indicators](#), page 1-28
- [Fans, Ventilation, and Airflow](#), page 1-38

Built-In Interface Ports

The Cisco 4000 Series ISR have multiple 10/100/1000 front panel ports, SFPs, and 10/100/1000 management ports.

Dual Mode GE/SFP Ports

There are dual mode ports available on the router that can function as GE or SFP ports.

GE Ports

The GE RJ-45 copper interface ports support 10BASE-T, 100BASE-TX, and 1000BASE-T.

SFP Ports

The small-form-factor pluggable (SFP) ports support, but are not restricted to 1000BASE-LX/LH, 1000BASE-SX, 1000BASE-ZX, and Coarse Wavelength-Division Multiplexing (CWDM-8) modules, as well as 100Mbs SFP modules.

The SFP port shares the same physical port as an RJ-45 GE port with the same number. It can only be used for one or the other function at one time. The SFP port supports auto-media-detection, auto-failover and remote fault indication (RFI), as described in the IEEE 802.3ah specification.

Use the **media-type {rj45{auto-failover}} | {sfp{auto-failover}}** command to enable the auto-media-detection and auto-failover features. Use the Command Lookup Tool for details about this command.

The SFP port can be configured for the following behaviors:

- Always use the RJ-45 port.
- Always use the SFP port.
- Always use the RJ-45 port but fail over to the SFP port if the RJ-45 port fails. This is the default configuration.
- Always use the SFP port but fail over to the RJ-45 port if the SFP port fails.

USB Serial Console Port

The Mini-USB type B serial port can be used as an alternative to the RJ-45 console port. For Windows operating systems older than Windows 7, you must install a Windows USB device driver before using the USB console port.

Front Panel PoE+ Ports

On the Cisco 4451-X ISR and Cisco 4351 ISR, two of the front panel Ethernet ports are PoE+ (802.3at) compliant ports. These are ports GE 0/0/0 and GE 0/0/1. The Cisco 4431 ISR, Cisco 4321 ISR and Cisco 4221 do not support front panel PoE+.

System PoE power supplies do not provide power to the front panel ports.

Internal PoE Daughter Card

The internal PoE daughter card provides a total of 30.8 watts of power across the two ports.

LED Indicators

Table 1-2 summarizes the LED indicators that are located in the router bezel or chassis, but not on the interface cards and modules.

Note

For module LEDs, please refer to the respective module installation guides for each module.

Table 1-2 LED Descriptions (Applies to the Cisco 4451-X ISR, Cisco 4431 ISR, and Cisco 4351 ISRs)

LED	Represents	Color	Description	Location	Available On
STAT	System Status	Solid green	System operating normally.	Bezel side	All models
		Blinking amber	BIOS/Rommon is booting.		
		Amber	BIOS/Rommon has completed booting, and system is at Rommon prompt or booting platform software.		
		Off	System is not out of reset or BIOS image is not loadable.		
TEMP	Temperature Status	Solid green	All temperature sensors in the system are within acceptable range.	Bezel side	All models
		Amber	One or more temperature sensors in the system are outside the acceptable range.		
		Off	Temperature is not being monitored.		
FAN	Fan Status	Green	All fans are operating.	Bezel side	All models
		Amber	One fan has stopped working.		
		Blinking Amber	Two or more fans have stopped working, or the fan tray has been removed.		
		Off	Fans are not being monitored.		
L (left)	Ethernet ports 0 and 1 Link	Green	Ethernet cable is present and link is established with other side or PoE power is enabled for this port.	I/O side	All models
		Off	No link.		
S (left)	Speed of Ethernet ports 0 and 1	Green	Blink frequency indicates port speed: <ul style="list-style-type: none"> 1 blink+ pause - FE or GE port operating at 10 Mb/s 2 blinks + pause - FE or GE port operating at 100 Mb/s 3 blinks + pause - GE port operating at 1000 Mb/s 	I/O side	All models
		Off			

Table 1-2 LED Descriptions (Applies to the Cisco 4451-X ISR, Cisco 4431 ISR, and Cisco 4351 ISRs) (continued)

LED	Represents	Color	Description	Location	Available On
L (right)	Ethernet ports 2 and 3 ¹ and Management Ethernet Link	Green	Ethernet cable is present and link is established with other side.	I/O side	All models
		Off	No link.		
S (right)	Ethernet ports 2, and 3 ¹ and Management Ethernet Speed	Green	Blink frequency indicates port speed: <ul style="list-style-type: none"> • 1 blink+ pause - FE or GE port operating at 10 Mb/s • 2 blinks + pause - FE or GE port operating at 100 Mb/s • 3 blinks + pause - GE port operating at 1000 Mb/s 	I/O side	All models
		Off	No link		
SFP EN	Port 0, 1, 2, and 3 Enable	Green	Present and enabled.	I/O side	All models ¹
		Amber	Present with failure.		
		Off	Not present.		
SFP S	Status of Ports 0, 1, 2, and 3	Blinking Green	Blinking frequency indicates port speed. See the definition for the S LED.	I/O side	All models ¹
		Amber	Initialized with error.		
		Off	Not present.		
SER CON (right)	Serial Console Active	Green	Indicates that the active console port is RJ-45. Note When this LED is on, the USB CON LED will be off.	I/O side	All models
USB CON (left)	USB Console Active	Green	Green indicates that the active console port is USB. Note When this LED is on, the SER CON LED will be off.	I/O side	All models
SSD	mSATA Slot Status	Green	SSD mSATA present and enabled.	Bezel side	Cisco ISR4351
		Amber	Initialized with error.		
		Off	Not present.		
ISC	ISC Slot Status	Green	PVDM4 is present and is enabled.	Bezel side	All models
		Amber	Initialized with error.		
		Off	Not present.		
FLASH	System Flash Status	Blinking Green	Compact flash/eUSB flash is present and is currently being accessed. Note Do not remove the flash device while the system is powered on.	Bezel side	All models

Table 1-2 LED Descriptions (Applies to the Cisco 4451-X ISR, Cisco 4431 ISR, and Cisco 4351 ISRs) (continued)

LED	Represents	Color	Description	Location	Available On
PSU	Power Supply Unit (P0 and P1) Status	Green	PSU is on and is providing power.	Bezel side	All models ²
		Amber	PSU is on but with errors or in a failure condition.		
		Off	Power supply is turned off.		
POE PSU (not supported in Cisco IOS XE 3.8)	Power Over Ethernet Power Supply Unit 0 and 1 Status	Green	PSU is on and providing power.	Bezel side	All models ^{1,2}
		Amber	PSU is on but with errors or in a failure condition.		
		Off	PSU is off.		
POE Boost (not supported in Cisco IOS XE 3.8)	Power Over Ethernet Boost Mode	Green	Two PoE power supplies are installed and operating in boost mode.	Bezel side	Cisco 4451-X ISR, Cisco ISR4431
		Off	This can mean one of the following: <ul style="list-style-type: none"> No PoE PSU installed. One PoE PSU installed. Two PoE PSUs installed and operating in redundant mode. 		
GE POE	Internal PoE Daughter Card Status	Green	PSU is installed and providing power	Bezel side	All models
		Amber	PSU is installed but in a failure condition.		
		Off	PSU is off.		
PWR	System Power	Green	System power is on and functioning correctly.	Bezel side	All models
		Green blinking	System power is in the process of shutting down.		
		Amber	System power is up, but low level initialization failed.		
		Amber blinking:	System power is up, but the system failed to come out of reset.		
		Off	System power is off.		
AC OK	AC power status	Green	AC power is on.	On each power supply unit	All models
		Off	AC power is off.		

1. The Cisco ISR4351 does not have SPF 3.

2. The Cisco ISR4351 does not support POE PSU 1.

Table 1-3 LED Descriptions (Applies to the Cisco 4331 ISR and the Cisco 4321 ISR Routers)

LED	Represents	Color	Description	Location	Available On
STAT	System Status	Solid green	System operating normally.	Bezel side	All models
		Blinking amber	BIOS/Rommon is booting.		
		Amber	BIOS/Rommon has completed booting, and system is at Rommon prompt or booting platform software.		
		Off	System is not out of reset or BIOS image is not loadable.		
TEMP	Temperature Status	Solid green	All temperature sensors in the system are within acceptable range.	Bezel side	All models
		Amber	One or more temperature sensors in the system are outside the acceptable range.		
		Off	Temperature is not being monitored.		
FAN	Fan Status	Green	All fans are operating.	Bezel side	All models
		Amber	One fan has stopped working.		
		Blinking Amber	Two or more fans have stopped working, or the fan tray has been removed.		
		Off	Fans are not being monitored.		
L	Ethernet ports 0 and 1 ¹	Green	Ethernet cable is present and link is established with other side.	I/O side	All models
		Off	No link.		
S	Speed of Ethernet ports 0 and 1	Green	Blink frequency indicates port speed: <ul style="list-style-type: none"> • 1 blink - 10-Mbps link speed • 2 blinks - 100-Mbps link speed • 3 blinks - 1000-Mbps link speed 	I/O side	All models
		Blinking			
		Off			
SFP EN	Port 0, and 1 (for Cisco 4331 ISR), and Port 0 for Cisco 4321 ISR) Enable	Green	Indicates that the SFP module detected and recognized.	I/O side	All models
		Amber	Initialized with error.		
		Off	Not present.		
SFP S	Status of port 0, and 1 (for Cisco 4331 ISR), and Port 0 for Cisco 4321 ISR)	Green	Indicates that the SFP module is detected and recognized.	I/O side	All models
		Amber	Initialized with error.		
		Off	Not present.		
		Off	Not present.		
SER CON (right)	Serial Console Active	Green	Indicates that the active console port is RJ-45. Note When this LED is on, the USB CON LED will be off.	I/O side ²	All models

LED	Represents	Color	Description	Location	Available On
USB CON (left)	USB Console Active	Green	Green indicates that the active console port is USB. Note When this LED is on, the SER CON LED will be off.	I/O side ²	All models
SSD	mSATA Slot Status	Green	SSD mSATA is present and enabled.	Bezel side	All models.
		Amber	Initialized with error.		
		Off	Not present.		
POE0	POE PSU	Green	PoE is on and providing power.	Bezel side	All models.
		Amber	PoE is in a failed condition.		
		Off	PoE supply is not present.		
ISC	ISC Slot Status	Green	PVDM4 is present and enabled.	Bezel side	All models
		Amber	Initialized with error.		
		Off	Not present.		
FLASH	System Flash Status	Blinking Green	Compact flash/eUSB flash is present and currently being accessed. Note Do not remove the flash device while the system is powered on.	Bezel side	All models
PWR	System Power	Green	System power is on and functioning correctly.	Bezel side	All models
		Green blinking	System power is in the process of shutting down.		
		Amber	System power is up, but low level initialization failed.		
		Amber blinking:	System power is up, but the system failed to come out of reset.		
		Off	System power is off.		

1. Management Ethernet Link on bezel side on the Cisco 4331 ISR.

2. These LEDs are on the bezel side for the Cisco 4331 ISR

Table 1-4 LED Descriptions (Applies to the Cisco 4221 ISR Router)

LED	Represents	Color	Description	Location	Available On
STAT	System Status	Solid green	System operating normally.	Bezel side	All models
		Blinking amber	BIOS/Rommon is booting.		
		Amber	BIOS/Rommon has completed booting, and system is at Rommon prompt or booting platform software.		
		Off	System is not out of reset or BIOS image is not loadable.		

LED	Represents	Color	Description	Location	Available On
TEMP	Temperature Status	Solid green	All temperature sensors in the system are within acceptable range.	Bezel side	All models
		Amber	One or more temperature sensors in the system are outside the acceptable range.		
		Off	Temperature is not being monitored.		
FAN	Fan Status	Green	All fans are operating.	Bezel side	All models
		Amber	One fan has stopped working.		
		Blinking Amber	Two or more fans have stopped working, or the fan tray has been removed.		
		Off	Fans are not being monitored.		
L	Ethernet ports 0 and 1 ¹	Green	Ethernet cable is present and link is established with other side.	I/O side	All models
		Off	No link.		
S	Speed of Ethernet ports 0 and 1	Green	Blink frequency indicates port speed: <ul style="list-style-type: none"> 1 blink - 10-Mbps link speed 2 blinks - 100-Mbps link speed 3 blinks - 1000-Mbps link speed 	I/O side	All models
		Blinking			
		Off			
SER CON (right)	Serial Console Active	Green	Indicates that the active console port is RJ-45. Note When this LED is on, the USB CON LED will be off.	I/O side ²	All models
USB CON (left)	USB Console Active	Green	Green indicates that the active console port is USB. Note When this LED is on, the SER CON LED will be off.	I/O side ²	All models
		Off	PoE supply is not present.		
ISC	ISC Slot Status	Green	PVDM4 is present and enabled.	Bezel side	All models
		Amber	Initialized with error.		
		Off	Not present.		
FLASH	System Flash Status	Blinking Green	Compact flash/eUSB flash is present and currently being accessed. Note Do not remove the flash device while the system is powered on.	Bezel side	All models

LED	Represents	Color	Description	Location	Available On
PWR	System Power	Green	System power is on and functioning correctly.	Bezel side	All models
		Green blinking	System power is in the process of shutting down.		
		Amber	System power is up, but low level initialization failed.		
		Amber blinking:	System power is up, but the system failed to come out of reset.		
		Off	System power is off.		

1. Management Ethernet Link on bezel side on the Cisco 4221 ISR.
2. These LEDs are on the bezel side for the Cisco 4221 ISR

Removable and Interchangeable Modules and Cards

Table 1-1 on page 1-25 summarizes the type of removable modules and cards that can be installed in the router to provide specific capabilities. Service Modules (SM-Xs), Network Interface Modules (NIMs), and E-Series Server Modules, fit into external slots and can be removed or replaced without opening the chassis.

External Slots

- [Network Interface Modules and Service Modules, page 1-35](#)
- [Cisco UCS E-Series Server Modules, page 1-35](#)
- [Solid State Drives, page 1-36](#)

Internal Slots

- [Packet Voice Digital Signal Processor Modules, page 1-36](#)
- [Memory, page 1-37](#)
- [System Flash, page 1-36](#)



Warning

Only trained and qualified personnel should be allowed to install, replace, or service this equipment. Statement 1030



Warning

This equipment must be installed and maintained by service personnel as defined by AS/NZS 3260. Incorrectly connecting this equipment to a general-purpose outlet could be hazardous. The telecommunications lines must be disconnected 1) before unplugging the main power connector or 2) while the housing is open, or both. Statement 1043

See the [Overview of Cisco Network Modules and Service Modules for Cisco Access Routers](#) document for general information and single- and double-wide slot numbering.

See the [“Installing and Removing NIMs and SM-Xs”](#) section on page 6-29 for instructions that describe how to install SM-Xs and NIMs in the router.

See the [Overview of Cisco Interface Cards for Cisco Access Routers](#) for general interface card information.

See the [Installing Cisco Interface Cards in Cisco Access Routers](#) document, for instructions that describe how to install legacy interface cards in the router.

**Note**

See the router product page on Cisco.com for a list of supported network modules and interface cards.

Network Interface Modules and Service Modules

To install NIMs and SM-X s on the router chassis, see the [“Installing and Removing NIMs and SM-Xs” section on page 6-29](#).

Cisco UCS E-Series Server Modules

The Cisco UCS E-Series Servers (E-Series Servers) are the next generation of Cisco UCS Express servers. E-Series Servers are a family of size, weight, and power efficient blade servers that are housed within the Generation 2 Cisco Integrated Services Routers (ISR G2) and the Cisco 4000 Series Integrated Services Router. These servers provide a general-purpose compute platform for branch-office applications deployed either as bare-metal on operating systems, such as Microsoft Windows or Linux; or as virtual machines on hypervisors, such as VMware vSphere Hypervisor™, Microsoft Hyper-V, or Citrix XenServer.

System Flash

The routers use a CompactFlash or an eUSB flash for the internal bootflash memory depending on the model that you have purchased. The CompactFlash and eUSB flash stores the operating system software image.

The CompactFlash is applicable only to the Cisco 4451-X ISR. Each model supports 1 internal CompactFlash 8-GB, 16-GB, or 32-GB memory card. The CompactFlash is located behind the fan tray on the router chassis.

The Cisco 4431 ISRs have a eMMC flash device. It supports 8GB, 16GB, or 32 GB.

The Cisco 4300 Series ISRs have an onboard flash device or a eMMC flash device. It supports 8GB or 16GB.

**Note**

For the Cisco 4451-X ISR, you must use Cisco-qualified CompactFlash cards. Use of any other cards during normal network operation can affect system performance or reliability.

**Note**

Do not run the router without a CompactFlash card installed. Cisco IOS XE software will not boot without a flash card in the router.

Solid State Drives

The NIM slots in the router support a field-replaceable solid state drive module with a dual-SSD SATA slot. The NIM can be installed in any bay slot 0. The SSDs are hot-swappable as part of normal operation. See the [“Locating Internal and External Slots for Modules on the Cisco 4331 ISR”](#) section on page 6-9 section for more information.

The Cisco ISR4300 platforms support optional internal SSD mSATA. This device is not hot-swappable and requires opening the chassis to service or upgrade.

Packet Voice Digital Signal Processor Modules

The Packet Voice Digital Signal Processor Modules (PVDM4s) add additional voice capabilities to the routers. The PVDM4 is installed inside the chassis of the router. See the [“Installing the PVDM4 on the Motherboard of the Router”](#) section on page 6-33 for installation instructions.

Memory

The routers contain the following types of memory:

- DIMMs—Stores the running configuration and routing tables and is used for packet buffering by the network interfaces. Cisco IOS XE software executes from memory. Supported module types are Dual In-Line Memory Modules (DIMMs).



Note

The DIMMs are interchangeable although the same sizes are not supported in all locations. The Cisco 4300 ISRs use a different type of DIMM compared to the 4400 ISRs. For proper operation, the DIMMs for the Cisco 4400 ISR should not be installed in an Cisco 4300 ISR and vice versa. The single forwarding plane DIMM must have a 2-GB DIMM that is exactly like one of the two DIMMs used for the control plane with 4 GB of default memory. The control plane uses two DIMMs and they must be exactly the same type and density. This applies to the Cisco ISR4400 series only. The Cisco 4300 ISRs do not have a distinct forwarding plane DIMM.

- Boot/NVRAM—Stores the bootstrap program (ROM monitor), and the configuration register. The boot/NVRAM is not serviceable.
- Flash memory—Internal bootflash memory. For details, see the “[System Flash](#)” section on [page 1-36](#).
- CompactFlash memory card (Cisco ISR4451-X routers)—Available in 8 GB, 16 GB, or 32 GB.
- eUSB flash card (Cisco ISR 4300 router)—Available in 8 GB or 16 GB.

Power Supply

The routers support a variety of power supply configurations. The power supplies are field-replaceable and externally accessible. The Cisco 4331 ISR power supply is not externally accessible, it is inside the chassis.

The Cisco 4451-X ISR and Cisco 4431 ISRs support dual, hot-swappable power supplies. The PoE Power Supply Converter on the Cisco 4451-X ISR is also dual and hot-swappable.

[Table 1-5](#) summarizes the power options.

Table 1-5 Field Replaceable Unit Power Options

Router Model	AC Input PSU	DC Input PSU	Dual, Hot Swap Power Supply	PoE Power Supply Converter
Cisco 4451-X ISR	X		X	X
Cisco 4431 ISR	X	X	X	
Cisco ISR4351	X			X
Cisco 4331 ISR	X			
Cisco 4321 ISR	X			
Cisco 4221 ISR	X	X		

Fans, Ventilation, and Airflow

Chassis Ventilation

Cooling is supported with internal fans. An onboard temperature sensor controls the fan speed. The fans are always on when the router is powered on. Under most conditions, the fans operate at the slowest speed to conserve power and reduce fan noise. The fans operate at the higher speeds when necessary under conditions of higher ambient temperature. To replace the Cisco 4451-X ISR, Cisco 4431 ISR, and Cisco ISR4351 fan trays, see the “Replacing a Fan Tray” section on page 6-54.

Figure 1-26 shows the Cisco 4451-X ISR airflow, Figure 1-27 shows the Cisco 4431 ISR airflow, Figure 1-28 shows the Cisco 4321 ISR airflow, and Figure 1-29 shows the Cisco 4221 ISR airflow.

Figure 1-26 Cisco 4451-X ISR Airflow

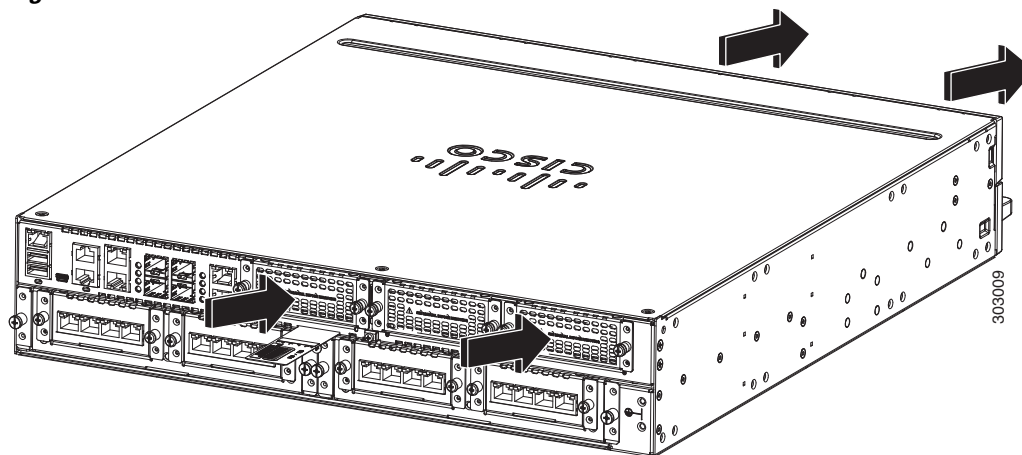

Figure 1-27 Cisco 4431 ISR Airflow

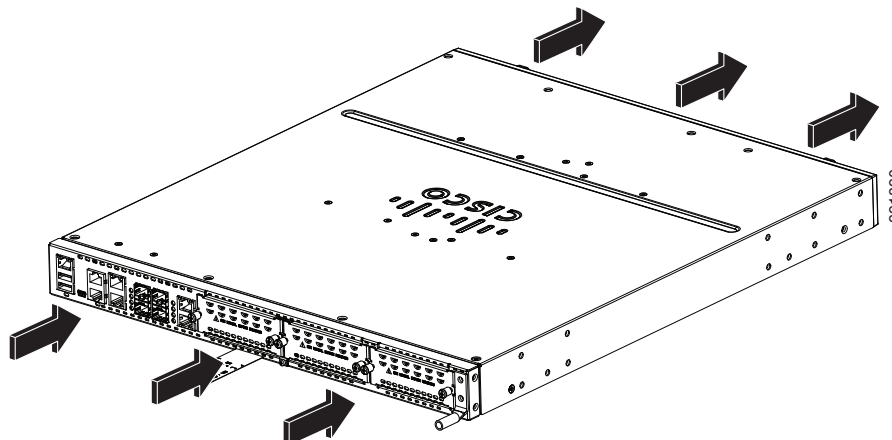
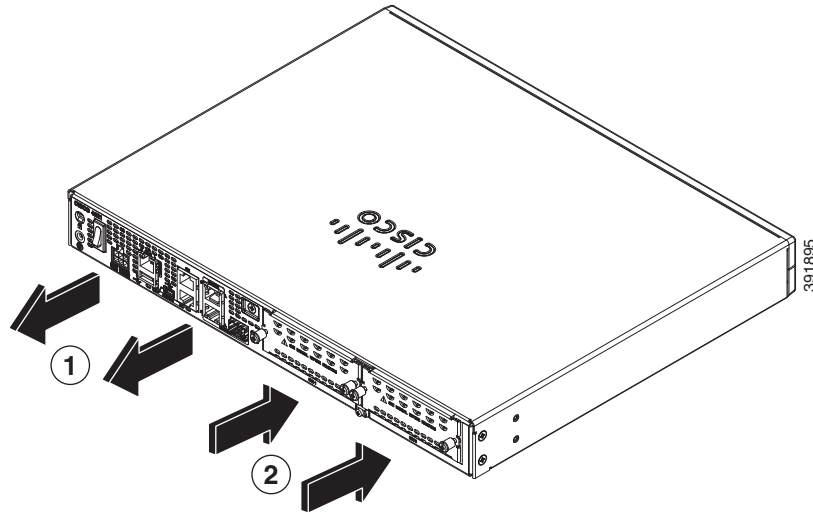
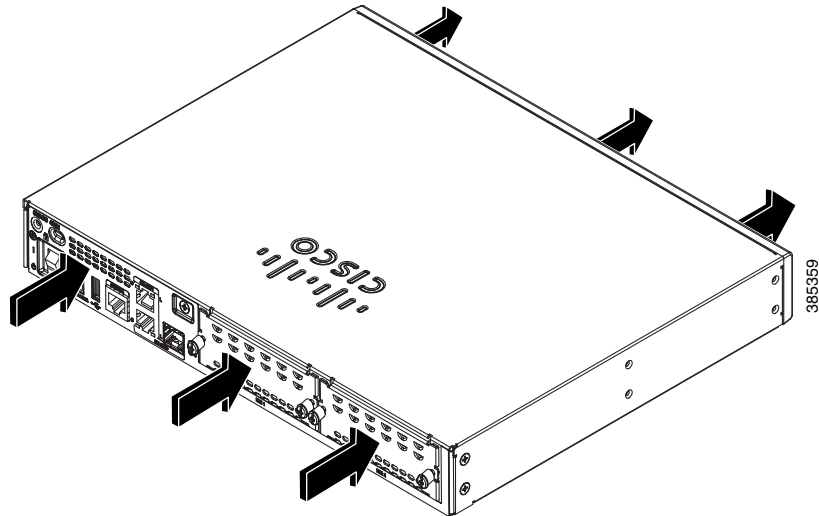

Figure 1-28 Cisco 4321 ISR Airflow



1	Exhaust	2	Intake
----------	---------	----------	--------

Figure 1-29 Cisco 4221 ISR Airflow



About Slots and Interfaces

This section covers the following topics:

- [About Slot, Subslot \(Bay\), and Port Numbering, page 1-40](#)
- [Slot Numbering, page 1-41](#)
- [Subslot/Bay Numbering, page 1-42](#)
- [Gigabit Ethernet Management, page 1-42](#)

About Slot, Subslot (Bay), and Port Numbering

The routers supports two types of interface modules: Enhanced Service Modules (SM-X) and Network Modules (NIMs).

In most cases, the router designates its interfaces using a 3-tuple notation that lists the slot, bay, and port. The 3-tuple value is zero based. An example of a 3-tuple is 0/1/2. This refers to slot 0, the second bay in slot 0 (the first bay is 0 so the second bay is 1), and the third port in bay 1. See [Table 1-6](#) for more examples.

Table 1-6 Slot, Subslot (Bay) and Port Numbering

3-Tuple Example	Slot	Bay	Port
0/1/2	0	2nd	3rd
0/0/1	0	1st	2nd
1/1/1	1	2nd	2nd

- Slots and bays are numbered from the left to the right, and from the top to the bottom.
- NIMs are designated by the number of the first slot that they occupy. A double-wide NIM occupies two slots, but its designation is only the left-most slot number.
- The auxiliary (AUX) serial port and console (CON) serial port do not have slot, bay, or port numbers.
- The GE management port is named GE 0 and has a port number. It does not have a slot or bay number.
- The two USB ports are named USB0 and USB1. They do not have slot or bay numbers. The Cisco ISR4331 and Cisco ISR4321 only have one USB port.



Note USB0 and USB1 can be used to insert flash drives.

[Figure 1-30](#) shows the ports and slots on the Cisco 4451-X ISRs.

Figure 1-30 Ports and Slots on the Cisco 4451-X ISRs

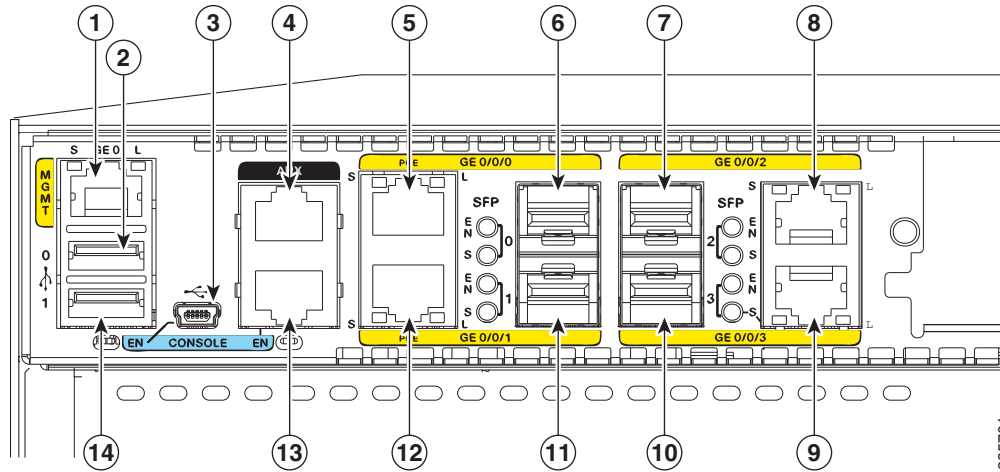

1	Gigabit Ethernet management port	2	USB port 0
3	USB Type B mini port	4	Auxiliary port
5	RJ-45 Gigabit Ethernet port (GE 0/0/0)	6	Small-form-factor pluggable (SFP) 0/Gigabit Ethernet port (GE 0/0/0)
7	SFP 2/Gigabit Ethernet port (GE 0/0/2)	8	RJ-45 Gigabit Ethernet port (GE 0/0/2)
9	RJ-45 Gigabit Ethernet port GE 0/0/3	10	SFP 3/Gigabit Ethernet GE 0/0/3
11	SFP 1/Gigabit Ethernet GE 0/0/1	12	RJ-45 Gigabit Ethernet port GE 0/0/1
13	Console port	14	USB port 1

Slot Numbering

Slots are numbered 0, 1 and 2.

About Slot 0

The following are the main features of Slot 0:

- Slot 0 is the motherboard and not removable. It is reserved for integrated ports and NIMs.
- The front panel GE ports (or native interface ports) always reside in slot 0 and bay 0. The ports are called Gigabitethernet 0/0/0, Gigabitethernet 0/0/1, Gigabitethernet 0/0/2, and Gigabitethernet 0/0/3 (up to as many ports supported on the particular router).
- PVDM4s do not have an external slot number. Therefore, the nomenclature for PVDM4s always has 0 in the first tuple. For example, the 3-tuple for an PVDM4 might be 0/4/x.

Subslot/Bay Numbering

- Integrated devices, also known as integrated ports or FPGEs, and integrated NIMs reside in a fixed section of bay 0.
- Main board NIMs bays start at bay 1, since the integrated devices and integrated NIMs take up bay 0.
- The bay numbers for PVDM4s start with the next bay number after the last NIM bay number.

Gigabit Ethernet Management

The Cisco 4000 Series ISR provides a Gigabit Ethernet Management port, called GE0. This port is the only 1-tuple port on the system. See the [Gigabit Ethernet Management Port](#) section in the *Software Configuration Guide for the Cisco ISR 4400 Series and Cisco ISR 4300 Series Routers* for additional information about the Gigabit Ethernet Management port.

Specifications

The following table provide Cisco 4451-X ISR specifications.

Table 1-7 Cisco 4451-X ISR Router Specifications

Description	Specification
Physical	
Dimensions (H x W x D)	3.5 x 17.25 x 18.7 in. (88.9 x 438.2 x 474.9 mm) 2 RU height
Weight with AC PS (w/o modules)	28.5 lbs (12.92 kg)
Weight with dual AC-PoE PS (w/o modules)	30.0 lbs (13.6 kg)
Weight with dual AC + PoE Adaptor (w/o modules)	38.0-40.0 lbs (17.23-18.14 kg)
Power	
AC input power	
• Input voltage	100 to 240 VAC, autoranging
• Frequency	47 to 63 Hz
• Input current	5.3 A
• Input current with PoE Power Adaptor	7.4 A
• Surge current	60 A peak and less than 12 Arms per half cycle
Power consumption	
• With AC-PoE	75 to 320 W, 256 to 1092 BTU/hr (configuration dependent) 80 to 750 W, 273 to 2560 BTU/hr (configuration dependent)
Ports	
Console port	One RJ-45 connector and one mini USB Type B, USB 2.0 compliant

Table 1-7 Cisco 4451-X ISR Router Specifications (continued)

Description	Specification
Auxiliary port	RJ-45 connector
USB ports	Two USB Type A, USB 2.0 compliant, 2.5 W (500 mA) max ¹
10/100/1000 Gigabit Ethernet	Four RJ-45 connectors (GE0/0/0, GE0/0/1, GE0/0/2, GE0/0/3), auto-MDIX
SFP	Once an SFP module is installed the adjacent RJ-45 GE connector is disabled.

1. 480 Mb/s individually, bandwidth is shared when both are used

The following table provide Cisco 4431 ISR specifications.

Table 1-8 Cisco 4431 ISR Specifications

Description	Specification
Physical	
Dimensions (H x W x D)	1.73 x 17.25 x 19.97 in. (43.9 x 438.15 x 507.2 mm)
Weight with 1 400-WAC power supply (no modules)	18.5 lb (8.4 kg)
Weight with 1 500-W AC+PoE power supply (no other modules)	18.6 lb (8.4 kg)
Power	
AC input power	
• Input voltage	100 to 240 VAC, autoranging
• Frequency	47 to 63 Hz
• Input current	2.88 A to 1.2 A
• Input current with AC+PoE power supply	5.76 A to 2.4 A
• Surge current	60 A peak and less than 12 Arms per half cycle
Power consumption	60 to 250 W (205 to 853 BTU/hr) (configuration dependent)
• With AC+PoE	60 to 440 W (205 to 1500 BTU/hr) (configuration dependent)
DC input power	
• Input voltage	-48 V to -60 V
• Input current	6 A to 4.8 A
• Power consumption	60 to 250 W
• Maximum output power	350 W
Ports	

Table 1-8 Cisco 4431 ISR Specifications (continued)

Description	Specification
Console port	One RJ-45 connector and one mini USB Type B, USB 2.0 compliant
Auxiliary port	RJ-45 connector
USB ports	Two USB Type A, USB 2.0 compliant, 2.5 W (500 mA) max ¹
10/100/1000 Gigabit Ethernet	Four RJ-45 connectors (GE0/0/0, GE0/0/1, GE0/0/2, GE0/0/3), auto-MDIX
SFP	When SFP0 is installed, GE0/0/0 is disabled. SFP/2 is dedicated (always on).

1. 480 Mb/s individually, bandwidth is shared when both are used

The following table provide Cisco 4351ISR specifications.

Table 1-9 Cisco 4351 ISR Specifications

Description	Specification
Physical	
Dimensions (H x W x D)	3.5 x 17.25 x 18.7 in. (88.9 x 438.2 x 474.9 mm), 2 RU height
Weight with AC PS (w/o modules)	28.8 lb (13.1 kg)
Weight with one AC 1,100 PS (w/o modules)	30.5 lbs (13.9 kg)
Power	
AC input power	
• Input voltage	100 to 240 VAC, autoranging
• Frequency	47 to 63 Hz
• Input current	5.3 A
• Input current with PoE Power Adaptor	7.4 A
• Surge current	60 A peak and less than 12 Arms per half cycle
Power consumption	75 to 320 W, 256 to 1092 BTU/hr (configuration dependent)
• With AC-PoE	80 to 750 W, 273 to 2560 BTU/hr (configuration dependent)
Ports	
Console port	One RJ-45 connector and one mini USB Type B, USB 2.0 compliant
Auxiliary port	RJ-45 connector
USB ports	Two USB Type A, USB 2.0 compliant, 2.5 W (500 mA) max ¹

Table 1-9 Cisco 4351 ISR Specifications (continued)

Description	Specification
10/100/1000 Gigabit Ethernet	Three RJ-45 connectors (GE0/0/0, GE0/0/1, GE0/0/2), auto-MDIX
SFP	Manual configuration is required to switch between the RJ-45 and the SFP module.

1. 480 Mb/s individually, bandwidth is shared when both are used

The following table provide Cisco 4331 ISR specifications.

Table 1-10 Cisco 4331 ISR Specifications

Description	Specification
Physical	
Dimensions (H x W x D)	1.75 x 17.25 x 17.25 in. (44.45 x 438.2 x 438.2 mm)
Weight with one AC PS (w/o modules)	13.50 lb (6.12 kg)
Power	
AC input power	
• Input voltage	100 to 240 VAC, autoranging
• Frequency	47 to 63 Hz
• Input current	2.4 A
• Input current with PoE Power Adaptor	4.8 A
• Surge current	60 A peak and less than 12 Arms per half cycle
Power consumption	
• With AC-PoE	60 to 440 W (205 to 1500 BTU/hr) (configuration dependent)
Ports	
Console port	One RJ-45 connector and one mini USB Type B, USB 2.0 compliant
Auxiliary port	RJ-45 connector
USB port	One USB Type A, USB 2.0 compliant, 2.5 W (500 mA) max ¹
10/100/1000 Gigabit Ethernet	Three Gigabit Ethernet ports, 2 RJ-45 connectors (GE 0/0/0, GE 0/0/1, GE 0/0/2), auto-MDIX
SFP	Manual configuration is required to switch between RJ-45 and SFP type. SFP/2 is dedicated (always on).

1. 480 Mb/s individually, bandwidth is shared when both are used

The following table provide Cisco 4321 ISR specifications.

Table 1-11 Cisco 4321 ISR Specifications

Description	Specification
Physical	
Dimensions (H x W x D)	1.75 x14.55 x11.60 in. (44.5 x 369.6.15 x 294.6 mm)
Weight with AC PS (w/o modules)	8.2 lb (3.7 kg)
Power	
AC input power	
• Input voltage	100 to 240 VAC, autoranging
• Frequency	47 to 63 Hz
• Input current	1 A
• Input current with PoE Power Adaptor	2.5 A
• Surge current	90 A peak and less than 8 Arms per half cycle
Power consumption	30 to 80 W (102 to 280 BTU/hr) (configuration dependent)
• With AC-PoE	30 to 200 W (102 to 675 BTU/hr) (configuration dependent)
Ports	
Console port	1 RJ-45 connector and one mini USB Type B, USB 2.0 compliant DONE
Auxiliary port	RJ-45 connector DONE
USB port	1 USB Type A, USB 2.0 compliant, 2.5 W (500 mA) max ¹ DONE
10/100/1000 Gigabit Ethernet	2 RJ-45 connectors and 1 SFP, (GE0/0/0, GE0/0/1, SFP0) auto-MDIX
SFP	Manual configuration is required to switch between RJ-45 and SFP type.

1. 480 Mb/s individually, bandwidth is shared when both are used

The following table provide Cisco 4221 ISR specifications.

Table 1-12 Cisco 4221 Specifications

Description	Specification
Physical	
Dimensions (H x W x D)	1.73 x12.7 x10.00 in. (44.5 x 369.6.15 x 294.6 mm)
Weight with AC PS (w/o modules)	5.3 Lbs. (2.4 kg) Router w/o modules + 1.5 Lbs. (0.68 kg) Power Supply (AC PSU)
Power	

Description	Specification
AC input power	
• Input voltage	85VAC to 264VAC (Label: 100-240VAC)
• Frequency	47 to 63 Hz
• Input current	1 A
• Input current with PoE Power Adaptor	2.5 A
• Surge current	90 A peak and less than 8 Arms per half cycle
Power consumption	Maximum power output 90W No load input power <= 0.15W at 230VAC input
DC input power	
• Input voltage	11.4 V to 12.6V(12V+/-5%)
• Input current	Maximum 7.5A
• Power consumption	The maximum continuous output power shall not exceed 90Watts
• Maximum output power	90 W
Ports	
Console port	One RJ-45: shared console port and auxiliary port
USB port	One USB Type A host port max
10/100/1000 Gigabit Ethernet	Two GE ports allocated among RJ45 and SFP as: One combo port with 10/100/1000RJ-45 Ethernet port or SFP Ethernet port (labeled GE0/0/0) One dedicated 10/100/1000RJ-45 Ethernet port (labeled GE0/0/1)
SFP	One SFP port (GE0/0/0)

Table 1-13 Environmental Specifications

Environmental	
Operating humidity	5 to 85% RH
Operating temperature	32 to 104°F (0 to 40°C)
Altitude in China	0-6560 ft (0-2000 m)
Altitude in all other countries	0-10,000 ft (0-3050 m)

Table 1-13 Environmental Specifications

Environmental	
Transportation and Storage	
Nonoperating temperature	-13 to 158°F (-25 to 70°C)
Nonoperating humidity	5 to 95% RH
Nonoperating altitude	15,000 ft (4570 m)
Acoustic (for ISR4451-X)	
Acoustic: Sound Pressure (Typical/Maximum)	54.4 to 67.4 dBA
Acoustic: Sound Power (Typical/Maximum)	62.6 to 74.5 dBA
Acoustic (for ISR4431)	
Acoustic: Sound Pressure (Typical/Maximum)	54.3 to 79.1 dBA
Acoustic: Sound Power (Typical/Maximum)	57.2 to 80.8 dBA
Acoustic (for ISR4351)	
Acoustic: Sound Pressure (Typical/Maximum)	50.6 to 73.1 dBA
Acoustic: Sound Power (Typical/Maximum)	58.2 to 78.8 dBA
Acoustic (for ISR4331)	
Acoustic: Sound Pressure (Typical/Maximum)	52.8 to 74.8 dBA
Acoustic: Sound Power (Typical/Maximum)	61.2 to 81.6 dBA
Acoustic (for ISR4321)	
Acoustic: Sound Pressure (Typical/Maximum)	24.2 to 51.9 dBA
Acoustic: Sound Power (Typical/Maximum)	31.9 to 59.9 dBA
Acoustic (for Cisco 4221 ISR)	
Acoustic: Sound Pressure (Typical/Maximum)	28.4 to 55.3 dBA
Acoustic: Sound Power (Typical/Maximum)	41 to 68 dBA

Table 1-14 *Regulatory Compliance Table*

Safety compliance	<p>IEC 60950-1, Safety of information technology equipment [world-wide]</p> <p>EN 60950-1:2006, Safety of information technology equipment [EU]</p> <p>UL 60950-1, Second Edition, Standard of safety for information technology equipment [US]</p> <p>CAN/CSA C22.2 No. 60950-1-07, Safety of information technology equipment including electrical business equipment [Canada]</p> <p>AS/NZS 60950.1: 2011 [Australia]</p> <p>GB 4943[PRC]</p> <p>IEC 60950-1: 2005 plus Am1: 2009, [World-wide]</p> <p>For detailed compliance information, see the Regulatory Compliance and Safety Information for the Cisco ISR 4400 and Cisco ISR 4300 Series Routers document.</p>
-------------------	--

Table 1-14 Regulatory Compliance Table

Immunity compliance	<p>CISPR24 ITE-Immunity characteristics, Limits and methods of measurement</p> <p>EN 55024 ITE-Immunity characteristics, Limits and methods of measurement</p> <p>EN 50082-1 Electromagnetic compatibility - Generic immunity standard - Part 1</p> <p>EN 300-386 V1.6.1 Electromagnetic compatibility for TNE</p> <p>EN 61000</p> <p>For detailed compliance information, see the Regulatory Compliance and Safety Information for the Cisco ISR 4400 and Cisco ISR 4300 Series Routers document.</p>
EMC compliance	<p>EN 55022, class A</p> <p>CISPR22, class A</p> <p>CFR47, Part 15, Subpart B, class A</p> <p>AS/NZS CISPR22, Class A</p> <p>VCCI, Class A</p> <p>CNS13438 (Taiwan)</p> <p>KN22:2009 (Korea)</p> <p>ICES-003</p> <p>Harmonic Current Emission</p> <p>EN 61000</p> <p>Voltage Fluctuation Flicker</p> <p>EN61000</p> <p>For detailed compliance information, see the Regulatory Compliance and Safety Information for the Cisco ISR 4400 and Cisco ISR 4300 Series Routers document.</p>

Periodic Inspection and Cleaning

Periodic inspection and cleaning of the external surface of the router is recommended to minimize the negative impact of environmental dust or debris. The frequency of inspection and cleaning is dependent upon the severity of the environmental conditions, but a minimum of every six months is recommended. Cleaning involves vacuuming of router air intake and exhaust vents. See the [“Fans, Ventilation, and Airflow”](#) section on page 1-38.

**Caution**

Sites with ambient temperatures consistently above 25°C or 77°F and with potentially high levels of dust or debris might require periodic preventative maintenance cleaning.



Preparing for Router Installation

This document provides preinstallation information, such as recommendations and requirements that should be before installing your router. See the following sections to prepare for installation:

- [Safety Recommendations, page 2-5](#)
- [General Site Requirements, page 2-7](#)
- [Rack Requirements, page 2-9](#)
- [Router Environmental Requirements, page 2-10](#)
- [Network Cabling Specifications, page 2-11](#)
- [Installation Checklist, page 2-16](#)
- [Creating a Site Log, page 2-17](#)
- To see translated warnings that appear in this publications, see the [Regulatory Compliance and Safety Information for the Cisco 4000 Series Routers](#) document

Standard Warning Statements

This section describes the warning definition and then lists core safety warnings grouped by topic.



Warning

This warning symbol means danger. You are in a situation that could cause bodily injury. Before you work on any equipment, be aware of the hazards involved with electrical circuitry and be familiar with standard practices for preventing accidents. Use the statement number provided at the end of each warning to locate its translation in the translated safety warnings that accompanied this device.

Note: SAVE THESE INSTRUCTIONS

Statement 1071

General Safety Warnings



Warning

Read the installation instructions before you connect the system to its power source. Statement 1004



Warning

Ultimate disposal of this product should be handled according to all national laws and regulations. Statement 1040



Warning

Installation of the equipment must comply with local and national electrical codes. Statement 1074



Warning

To comply with the Class A emissions requirements shielded twisted pair T1/E1 cables must be used for SPA-8-Port Channelized T1/E1 SPA (SPA-8XCHT1/E1) on the router. EN55022/CISPR22 Statement



Warning

To comply with Class A emissions requirements- shielded management Ethernet, CON, and AUX cables on the router must be used.



Warning

Power cable and AC adapter - When installing the product, please use the provided or designated connection cables/power cables/AC adaptors. Using any other cables or adapters could cause a malfunction or a fire. Electrical Appliance and Material Safety Law prohibits the use of certified cables (that have the 'UL' shown on the code) for any other electrical devices than products designated by Cisco. The use of cables that are certified by Electrical Appliance and Material Safety Law (that have 'PSE' shown on the code) is not limited to Cisco-designated products. Statement 371



Warning

Only trained and qualified personnel should be allowed to install or replace this equipment Statement 1030



Warning

This product relies on the building's installation for short-circuit (overcurrent) protection. Ensure that the protective device is rated not greater than: AC power supplies for the Cisco 4451-X ISR. Statement 1005



Warning

This product requires short-circuit (overcurrent) protection to be provided as part of the building installation. Install only in accordance with national and local wiring regulations. Statement 1045



Warning

This unit may have more than one power supply connection. All connections must be removed to de-energize the unit. Statement 1028

-  **Warning** This unit is intended for installation in restricted access areas. A restricted access area can be accessed only through the use of a special tool, lock and key, or other means of security. Statement 1017
-  **Warning** The plug-socket combination must be accessible at all times, because it serves as the main disconnecting device. Statement 1019
-  **Warning** Hazardous voltage or energy may be present on the DC power terminals. Always replace cover when terminals are not in service. Be sure uninsulated conductors are not accessible when cover is in place. Statement 1075
-  **Warning** Use copper conductors only. Statement 1025
-  **Warning** This equipment must be grounded. Never defeat the ground conductor or operate the equipment in the absence of a suitably installed ground conductor. Contact the appropriate electrical inspection authority or an electrician if you are uncertain that suitable grounding is available. Statement 1024
-  **Warning** Hazardous voltage or energy is present on the backplane when the system is operating. Use caution when servicing. Statement 1034
-  **Warning** Class 1 laser product. Statement 1008
-  **Warning** Class 1 LED product. Statement 1027
-  **Warning** Laser radiation is present when the system is open. Statement 1009
-  **Warning** Do not stare into the laser beam. Statement 1010
-  **Warning** Invisible laser radiation may be emitted from disconnected fibers or connectors. Do not stare into beams or view directly with optical instruments. Statement 1051
-  **Warning** Class I(CDRH) and Class 1M (IEC) laser products. Statement 1055

**Warning**

Invisible laser radiation may be emitted from the end of the unterminated fiber cable or connector. Do not view directly with optical instruments. Viewing the laser output with certain optical instruments (for example, eye loupes, magnifiers, and microscopes) within a distance of 100 mm may pose an eye hazard. Statement 1056

**Warning**

There is the danger of explosion if the battery is replaced incorrectly. Replace the battery only with the same or equivalent type recommended by the manufacturer. Dispose of used batteries according to the manufacturer's instructions. Statement 1015

**Warning**

Do not touch or bridge the metal contacts on the battery. Unintentional discharge of the batteries can cause serious burns. Statement 341

**Warning**

To prevent personal injury or damage to the chassis, never attempt to lift or tilt the chassis using the handles on modules (such as power supplies, fans, or cards); these types of handles are not designed to support the weight of the unit. Statement 1032

**Warning**

To prevent the system from overheating, do not operate it in an area that exceeds the maximum recommended ambient temperature of: 40 degrees C. Statement 1047

**Warning**

This equipment must be externally grounded using a customer-supplied ground wire before power is applied. Contact the appropriate electrical inspection authority or an electrician if you are uncertain that suitable grounding is available. Statement 366

**Warning**

Blank faceplates and cover panels serve three important functions: they prevent exposure to hazardous voltages and currents inside the chassis; they contain electromagnetic interference (EMI) that might disrupt other equipment; and they direct the flow of cooling air through the chassis. Do not operate the system unless all cards, faceplates, front covers, and rear covers are in place. Statement 1029

**Warning**

Only trained and qualified personnel should be allowed to install, replace, or service this equipment. Statement 1030

**Warning**

This equipment must be installed and maintained by service personnel as defined by AS/NZS 3260. Incorrectly connecting this equipment to a general-purpose outlet could be hazardous. The telecommunications lines must be disconnected 1) before unplugging the main power connector or 2) while the housing is open, or both. Statement 1043

**Warning**

This unit might have more than one power supply connection. All connections must be removed to de-energize the unit. Statement 1028

**Warning**

Hazardous network voltages are present in WAN ports regardless of whether power to the unit is OFF or ON. To avoid electric shock, use caution when working near WAN ports. When detaching cables, detach the end away from the unit first. Statement 1026

**Warning**

Before opening the unit, disconnect the telephone-network cables to avoid contact with telephone-network voltages. Statement 1041

**Warning**

Do not use this product near water; for example, near a bath tub, wash bowl, kitchen sink or laundry tub, in a wet basement, or near a swimming pool. Statement 1035

**Warning**

Never install telephone jacks in wet locations unless the jack is specifically designed for wet locations. Statement 1036

**Warning**

No user-serviceable parts inside. Do not open. Statement 1073

**Warning**

Never touch uninsulated telephone wires or terminals unless the telephone line has been disconnected at the network interface. Statement 1037

**Warning**

Avoid using a telephone (other than a cordless type) during an electrical storm. There may be a remote risk of electric shock from lightning. Statement 1038

**Warning**

To report a gas leak, do not use a telephone in the vicinity of the leak. Statement 1039

Safety Recommendations

Follow these guidelines to ensure general safety:

Review the safety warnings listed in [Regulatory Compliance and Safety Information for the Cisco 4000 Series ISRs](#) that comes with your router, before installing, configuring, or maintaining the router

- Review the safety warnings listed in that comes with your router, before installing, configuring, or maintaining the router.
- Never attempt to lift an object that might be too heavy for you to lift by yourself.
- Keep the chassis area clear and dust-free during and after installation.

- If you remove the chassis cover, put it in a safe place.
- Keep tools and chassis components away from walk areas.
- Do not wear loose clothing that could get caught in the chassis. Fasten your tie or scarf and roll up your sleeves.
- Wear safety glasses when working under conditions that might be hazardous to your eyes.
- Do not perform any action that creates a hazard to people or makes the equipment unsafe.

Safety with Electricity



Warning

This unit might have more than one power supply connection. All connections must be removed to de-energize the unit. Statement 1028



Warning

Do not work on the system or connect or disconnect cables during periods of lightning activity. Statement 1001



Warning

Read the installation instructions before connecting the system to the power source. Statement 1004



Warning

The covers are an integral part of the safety design of the product. Do not operate the unit without the covers installed. Statement 1077

Follow these guidelines when working on equipment powered by electricity:

- Locate the emergency power-off switch in the room in which you are working. If an electrical accident occurs, you can quickly turn off the power.
- Disconnect all power before doing the following:
 - Installing or removing a chassis
 - Working near power supplies
- Look carefully for possible hazards in your work area, such as moist floors, ungrounded power extension cables, frayed power cords, and missing safety grounds.
- Do not work alone if hazardous conditions exist.
- Never assume that power is disconnected from a circuit. Always check.
- Never open the enclosure of the internal power supply.
- If an electrical accident occurs, proceed as follows:
 - Use caution; do not become a victim yourself.
 - Turn off power to the device.
 - If possible, send another person to get medical aid. Otherwise, assess the condition of the victim and then call for help.
 - Determine if the person needs rescue breathing or external cardiac compressions; then take appropriate action.

In addition, use the following guidelines when working with any equipment that is disconnected from a power source but still connected to telephone wiring or other network cabling:

- Never install telephone wiring during a lightning storm.
- Never install telephone jacks in wet locations unless the jack is specifically designed for it.
- Never touch uninsulated telephone wires or terminals unless the telephone line is disconnected at the network interface.
- Use caution when installing or modifying telephone lines.
- Remove power cables from all installed power supplies before opening the chassis.

Preventing Electrostatic Discharge Damage

Electrostatic discharge (ESD) can damage equipment and impair electrical circuitry. It can occur if electronic printed circuit cards are improperly handled and can cause complete or intermittent failures. Always follow ESD prevention procedures when removing and replacing modules:

- Ensure that the router chassis is electrically connected to ground.
- Wear an ESD-preventive wrist strap, ensuring that it makes good skin contact. Connect the clip to an unpainted surface of the chassis frame to channel unwanted ESD voltages safely to ground. To guard against ESD damage and shocks, the wrist strap and cord must operate effectively.
- If no wrist strap is available, ground yourself by touching a metal part of the chassis.



Caution

For the safety of your equipment, periodically check the resistance value of the anti-static strap. It should be between 1 and 10 megohms (Mohm).

General Site Requirements

This section describes the requirements your site must meet for safe installation and operation of your router. Ensure that the site is properly prepared before beginning installation. If you are experiencing shutdowns or unusually high errors with your existing equipment, this section can also help you isolate the cause of failures and prevent future problems.

General Precautions

Observe the following general precautions when using and working with your Cisco 4451-X ISR.

- Keep your system components away from radiators and heat sources and do not block cooling vents.
- Do not spill food or liquids on your system components and never operate the product in a wet environment.
- Do not push any objects into the openings of your system components. Doing so can cause fire or electric shock by shorting out interior components.
- Position system cables and power supply cables carefully. Route system cables and the power supply cable and plug so that they cannot be stepped on or tripped over. Be sure that nothing else rests on your system component cables or power cable.

- Do not modify power cables or plugs. Consult a licensed electrician or your power company for site modifications. Always follow your local and national wiring rules.
- If you turn off your system, wait at least 30 seconds before turning it on again to avoid system component damage.

Site Selection Guidelines

The Cisco 4000 Series ISRs require specific environmental operating conditions. Temperature, humidity, altitude, and vibration can affect the performance and reliability of the router. The following sections provide specific information to help you plan for the proper operating environment.

The Cisco 4000 Series ISRs are designed to meet the industry EMC, safety, and environmental standards described in the [Regulatory Compliance and Safety Information for the Cisco 4000 Series ISRs](#) document.

Site Environmental Requirements

Environmental monitoring in the router protects the system and components from damage caused by excessive voltage and temperature conditions. To ensure normal operation and avoid unnecessary maintenance, plan and prepare your site configuration *before* installation. After installation, make sure the site maintains the environmental characteristics as shown in [Table 2-1](#).

Table 2-1 Router Environmental Tolerances

Environmental Characteristic	Minimum	Maximum
Steady State Operating	0 degree C	40 degree C (40 degrees C at 10,000 feet)
Storage	-20 degrees C	+70 degrees C
Humidity operating (noncondensing)	10%	90%
Humidity nonoperating (noncondensing)	5%	95%
Altitude operating: over allowable temperature range (0 to 50 degrees C)	-500 feet	10,000 feet
Altitude, nonoperating: over allowable temperature range	-1000 feet	50,000 feet
Thermal shock non-operating with change over time of 3 minute	-25 degrees C	+70 degrees C
Thermal Shock - Operating at 2.5 degree C per minute	0 degrees C	+50 degrees C

Physical Characteristics

Be familiar with the physical characteristics of the Cisco 4451-X ISR to assist you in placing the system in the proper location.

Table 2-2 shows the weight and dimensions of the Cisco 4451-X ISR.

Table 2-2 Physical Characteristics of Cisco 4451-X ISRs

Characteristics	Cisco 4451-X ISRs
Height	3.5 in. (8.89 cm.)—2RU rack-mount
Width	17.25 in. (43.815 cm.)—19-inch rack-mount
Depth	18.7 in. (47.498 cm.) (including card handles, cable-management brackets, power supply handles)
Weight	38-40 lbs (17.23-18.14 kg)

The following list describes additional Cisco 4451-X ISR chassis characteristics:

- Chassis height meets EIA-310 rack spacing 2RU (3.5 inches/88.90 mm.), universal rack-mount
- Chassis width meets EIA-310 19-inch (17.25 inches/438.15 mm) wide with rack brackets
- Cable-management brackets at each Cisco 4451-X ISR locations can hold 16 ports of STP/UTP RJ 45 cables
- Cable-management brackets allow a bend radius of 1.5 inches for cables
- Adjustable rack-mount brackets allow for a front to rear rail variance distance of 15.50/394mm to 19.00/482.6mm

Rack Requirements

Some Cisco routers include brackets for use with a 19-inch rack or, if specified in your order, optional larger brackets for use with a 23-inch rack.

The following information can help you plan your equipment rack configuration:

- Allow clearance around the rack for maintenance.
- Allow at least one rack unit of vertical space between routers.
- Enclosed racks must have adequate ventilation. Ensure that the rack is not congested, because each router generates heat. An enclosed rack should have louvered sides and a fan to provide cooling air. Heat generated by equipment near the bottom of the rack can be drawn upward into the intake ports of the equipment above it.
- When mounting a chassis in an open rack, ensure that the rack frame does not block the intake or exhaust ports. If the chassis is installed on slides, check the position of the chassis when it is seated in the rack.

Router Environmental Requirements

Cisco 4451-X ISRs can be placed on a desktop or installed in a rack. The location of your router and the layout of your equipment rack or wiring room are extremely important considerations for proper operation. Equipment placed too close together, inadequate ventilation, and inaccessible panels can cause malfunctions and shutdowns, and can make maintenance difficult. Plan for access to both front and rear panels of the router.

When planning your site layout and equipment locations, refer to the [“General Site Requirements” section on page 2-7](#), section. If you are currently experiencing shutdowns or an unusually high number of errors with your existing equipment, these precautions and recommendations may help you isolate the cause of failure and prevent future problems.

- Ensure that the room where your router operates has adequate air circulation. Electrical equipment generates heat. Without adequate air circulation, ambient air temperature may not cool equipment to acceptable operating temperatures.
- Always follow ESD-prevention procedures described in the [“Preventing Electrostatic Discharge Damage” section on page 2-7](#) to avoid damage to equipment. Damage from static discharge can cause immediate or intermittent equipment failure.
- Ensure that the chassis cover and module rear panels are secure. All empty network module slots, interface card slots, and power supply bays must have filler panels installed. The chassis is designed to allow cooling air to flow within it, through specially designed cooling slots. A chassis with uncovered openings permits air leaks, which may interrupt and reduce the flow of air across internal components.
- Baffles can help to isolate exhaust air from intake air, which also helps to draw cooling air through the chassis. The best placement of the baffles depends on the airflow patterns in the rack, which can be found by experimenting with different configurations.
- When equipment installed in a rack (particularly in an enclosed rack) fails, try operating the equipment by itself, if possible. Power off other equipment in the rack (and in adjacent racks) to allow the router under test a maximum of cooling air and clean power.

Power Guidelines and Requirements

Check the power at your site to ensure that you are receiving “clean” power (free of spikes and noise). Install a power conditioner if necessary.

The AC power supply includes the following features:

- Autoselects either 110 V or 220 V operation.
- All units include a 6-foot (1.8-meter) electrical power cord. (A label near the power inlet indicates the correct voltage, frequency [AC-powered systems only], current draw, and power dissipation for the unit.)

Table 2-3 lists power requirements for the Cisco 4451-X ISRs.

Table 2-3 Power Requirements for Cisco 4451-X ISRs

Router	Power Source	Input Power	Input Voltage Tolerance Limits
Cisco 4451-X ISR	AC	100 — 240 VAC, 5.3 A, 50 — 60 Hz	90 — 264 VAC
Cisco 4451-X ISR with PoE	AC	100 — 240 VAC, 11.0 A, 50 — 60 Hz	90 — 264 VAC

Network Cabling Specifications

The following sections describe the cables needed to install your Cisco 4451-X ISR in the following sections:

- [Console and Auxiliary Port Considerations, page 2-11](#)
- [Preparing for Network Connections, page 2-14](#)

Console and Auxiliary Port Considerations

The router includes an asynchronous serial console port and an auxiliary port. The console and auxiliary ports provide access to the router either locally using a console terminal connected to the console port, or remotely using a modem connected to the auxiliary port. This section discusses important cabling information to consider before connecting the router to a console terminal or modem.

The main difference between the console and auxiliary ports is that the auxiliary port supports hardware flow control and the console port does not. Flow control paces the transmission of data between a sending device and a receiving device. Flow control ensures that the receiving device can absorb the data sent to it before the sending device sends more. When the buffers on the receiving device are full, a message is sent to the sending device to suspend transmission until the data in the buffers has been processed. Because the auxiliary port supports flow control, it is ideally suited for use with the high-speed transmissions of a modem. Console terminals send data at speeds slower than modems do; therefore, the console port is ideally suited for use with console terminals.



Note

The Cisco 4221 ISR does not have an auxiliary port.

Console Port Connections

The router has both EIA/TIA-232 asynchronous (RJ-45) and USB 5-pin mini Type B, 2.0 compliant serial console ports. The console ports do not have any hardware flow control. Shielded USB cables with properly terminated shields are recommended.

EIA/TIA-232

Depending on the cable and the adapter used, this port appears as a DTE or DCE device at the end of the cable. Only one port can be used at the same time.

The default parameters for the console port are 9600 baud, 8 data bits, 1 stop bit, and no parity. The console port does not support hardware flow control. For detailed information about installing a console terminal, see the [“Connecting to a Console Terminal or Modem”](#) section on page 3-25.

For cable and port pinouts, see the [Cisco Modular Access Router Cable Specifications](#) document located on Cisco.com.

USB Serial Console

The USB serial console port connects directly to the USB connector of a PC using a USB Type A to 5-pin mini USB Type-B cable. The USB Console supports full speed (12Mb/s) operation. The console port does not support hardware flow control.



Note

Always use shielded USB cables with a properly terminated shield.

The default parameters for the console port are 9600 baud, 8 data bits, no parity, and 1 stop bit. For detailed information about installing a console terminal, see the [“Connecting to a Console Terminal or Modem”](#) section on page 3-25.

For operation with a Microsoft Windows OS version older than Windows 7, the Cisco Windows USB Console Driver must be installed on any PC connected to the console port. If the driver is not installed, prompts guide you through a simple installation process. For detailed information about installing the Cisco Windows USB Console Driver see [“Installing the Cisco Microsoft Windows USB Device Driver”](#) section on page 3-27.

The Cisco Windows USB Console Driver allows plugging and unplugging the USB cable from the console port without affecting Windows HyperTerminal operations. No special drivers are needed for Mac OS X or Linux.

Only one console port can be active at a time. When a cable is plugged into the USB console port, the RJ-45 port becomes inactive. Conversely, when the USB cable is removed from the USB port, the RJ-45 port becomes active.

Baud rates for the USB console port are 1200, 2400, 4800, 9600, 19200, 38400, 57600, and 115200 bps.



Note

4-pin mini USB Type-B connectors are easily confused with 5-pin mini USB Type-B connectors. Only the 5-pin mini USB Type-B is supported.

USB Console OS Compatibility

- Windows 8, Windows 7, Windows 2000, Window XP 32 bit, Windows Vista 32 bit
- Mac OS X version 10.5.4
- Redhat / Fedora Core 10 with kernel 2.6.27.5-117

- Ubuntu 8.10 with kernel 2.6.27-11
- Debian 5.0 with kernel 2.6
- Suse 11.1 with kernel 2.6.27.7-9

Auxiliary Port Connections

The router has an EIA/TIA-232 asynchronous serial auxiliary port (RJ-45) that supports flow control. Depending on the cable and the adapter used, this port appears as a DTE or DCE device at the end of the cable.

For connection to a modem, you must use an RJ-45-to-DB-25 adapter cable. This cable is orderable separately along with a DB-9-to-DB-25 adapter.

For detailed information about connecting devices to the auxiliary port, see the [“Connecting to a Console Terminal or Modem”](#) section on page 3-25.

For cable and port pinouts, see the [Cisco Modular Access Router Cable Specifications](#) document at Cisco.com.

Preparing for Network Connections

When setting up your router, consider distance limitations and potential electromagnetic interference (EMI) as defined by the applicable local and international regulations.

Network connection considerations are provided for:

- [Ethernet Connections, page 2-14](#)

See the following online document for more information about network connections and interfaces:

- [Cisco Modular Access Router Cable Specifications](#)



Warning

To avoid electric shock, do not connect safety extra-low voltage (SELV) circuits to telephone-network voltage (TNV) circuits. LAN ports contain SELV circuits, and WAN ports contain TNV circuits. Some LAN and WAN ports both use RJ-45 connectors. Statement 1021

Ethernet Connections

The IEEE has established Ethernet as standard IEEE 802.3. The routers support the following Ethernet implementations:

- 1000BASE-T—1000 Mb/s full-duplex transmission over a Category 5 or better unshielded twisted-pair (UTP) cable. Supports the Ethernet maximum length of 328 feet (100 meters).
- 100BASE-T—100 Mb/s full-duplex transmission over a Category 5 or better unshielded twisted-pair (UTP) cable. Supports the Ethernet maximum length of 328 feet (100 meters).
- 10BASE-T—10 Mb/s full-duplex transmission over a Category 5 or better unshielded twisted-pair (UTP) cable. Supports the Ethernet maximum length of 328 feet (100 meters).

See the [Cisco Modular Access Router Cable Specifications](#) document at Cisco.com for information about Ethernet cables, connectors, and pinouts.

Required Tools and Equipment for Installation and Maintenance



Warning

Only trained and qualified personnel should be allowed to install, replace, or service this equipment. Statement 1030



Warning

This equipment must be installed and maintained by service personnel as defined by AS/NZS 3260. Incorrectly connecting this equipment to a general-purpose outlet could be hazardous. The telecommunications lines must be disconnected 1) before unplugging the main power connector or 2) while the housing is open, or both. Statement 1043

You need the following tools and equipment to install and upgrade the router and its components:

- ESD-preventive cord and wrist strap
- Number 2 Phillips screwdriver
- Phillips screwdrivers: small, 3/16-in. (4 to 5 mm) and medium, 1/4-in. (6 to 7 mm)
 - To install or remove modules
 - To remove the cover, if you are upgrading memory or other components
- Screws that fit your rack
- Wire crimper
- Wire for connecting the chassis to an earth ground:
 - AWG 6 (13 mm²) wire for NEBS-compliant chassis grounding
 - AWG 14 (2 mm²) or larger wire for NEC-compliant chassis grounding
 - AWG 18 (1 mm²) or larger wire for EN/IEC 60950-compliant chassis grounding
- For NEC-compliant grounding, an appropriate user-supplied ring terminal, with an inner diameter of 1/4 in. (5 to 7 mm)

In addition, depending on the type of modules you plan to use, you might need the following equipment to connect a port to an external network:

- Cables for connection to the WAN and LAN ports (dependent on configuration)



Note For more information on cable specifications, see the [Cisco Modular Access Router Cable Specifications document](#) at Cisco.com.

- Ethernet hub or PC with a network interface card for connection to an Ethernet (LAN) port.
- Console terminal (an ASCII terminal or a PC running HyperTerminal or similar terminal emulation software) configured for 9600 baud, 8 data bits, 1 stop bit, no flow control, and no parity.
- Modem for connection to the auxiliary port for remote administrative access (optional).
- Data service unit (DSU) or channel service unit/data service unit (CSU/DSU) as appropriate for serial interfaces.
- External CSU for any CT1/PRI modules without a built-in CSU.

Installation Checklist

The sample installation checklist lists items and procedures for installing a new router. Make a copy of this checklist and mark the entries when completed. Include a copy of the checklist for each router in your site log (described in the next section, “[Creating a Site Log](#)”).

Installation checklist for site _____

Router name _____

Task	Verified by	Date
Installation checklist copied		
Background information placed in Site Log		
Site power voltages verified		
Installation site power check completed		
Required tools available		
Additional equipment available		
Router received		
Router quick start guide received		
<i>Regulatory Compliance and Safety Information for the Cisco ISR 4400 and Cisco ISR 4300 Series Routers</i> document received		
Product registration card received		
Cisco.com contact information label received		
Chassis components verified		
Initial electrical connections established		
ASCII terminal (for local configuration) or modem (for remote configuration) available		
Signal distance limits verified		
Startup sequence steps completed		
Initial operation verified		
Software image verified		

Creating a Site Log

The Site Log provides a record of all actions related to the router. Keep it in an accessible place near the chassis where anyone who performs tasks has access to it. Use the installation checklist to verify steps in the installation and maintenance of the router. Site Log entries might include the following information:

- Installation progress—Make a copy of the installation checklist and insert it into the site log. Make entries as each procedure is completed.
- Upgrade and maintenance procedures—Use the site log as a record of ongoing router maintenance and expansion history. A site log might include the following events:
 - Installation of network modules
 - Removal or replacement of network modules and other upgrades
 - Configuration changes
 - Maintenance schedules and requirements
 - Maintenance procedures performed
 - Intermittent problems
 - Comments and notes

Inspect all items for shipping damage. If anything appears to be damaged or if you encounter problems installing or configuring your router, contact customer service. Warranty, service, and support information is in the quick start guide that shipped with your router, or in the Preface of this guide. See the [“Obtaining Documentation and Submitting a Service Request”](#) section on page -xx.



Installing and Connecting the Router

This document describes how to install and connect the Cisco 4000 Series Integrated Services Routers (ISRs) to LAN, WAN, and Voice networks. The following sections provide technical details.

- [Installing the Router, page 3-4](#)
- [Chassis Grounding, page 3-22](#)
- [Connecting Power, page 3-23](#)
- [Connecting to a Console Terminal or Modem, page 3-25](#)
- [Installing the Cisco Microsoft Windows USB Device Driver, page 3-27](#)
- [Uninstalling the Cisco Microsoft Windows USB Driver, page 3-29](#)
- [Connecting WAN, LAN, and Voice Interfaces, page 3-30](#)



Warning

To see translations of the warnings that appear in this publication, see the *Regulatory Compliance and Safety Information for the Cisco 4000 Series ISRs* document. **Only trained and qualified personnel should be allowed to install, replace, or service this equipment.** Statement 1030



Warning

This unit might have more than one power supply connection. All connections must be removed to de-energize the unit. Statement 1028



Warning

Blank faceplates and cover panels serve three important functions: they prevent exposure to hazardous voltages and currents inside the chassis; they contain electromagnetic interference (EMI) that might disrupt other equipment; and they direct the flow of cooling air through the chassis. Do not operate the system unless all cards, faceplates, front covers, and rear covers are in place. Statement 1029



Warning

Hazardous network voltages are present in WAN ports regardless of whether power to the unit is OFF or ON. To avoid electric shock, use caution when working near WAN ports. When detaching cables, detach the end away from the unit first. Statement 1026

**Warning**

This equipment must be grounded. Never defeat the ground conductor or operate the equipment in the absence of a suitably installed ground conductor. Contact the appropriate electrical inspection authority or an electrician if you are uncertain that suitable grounding is available. Statement 1024

**Warning**

Before opening the unit, disconnect the telephone-network cables to avoid contact with telephone-network voltages. Statement 1041

**Warning**

Do not use this product near water; for example, near a bath tub, wash bowl, kitchen sink or laundry tub, in a wet basement, or near a swimming pool. Statement 1035

**Warning**

Never install telephone jacks in wet locations unless the jack is specifically designed for wet locations. Statement 1036

**Warning**

Never touch uninsulated telephone wires or terminals unless the telephone line has been disconnected at the network interface. Statement 1037

**Warning**

Avoid using a telephone (other than a cordless type) during an electrical storm. There may be a remote risk of electric shock from lightning. Statement 1038

**Warning**

To report a gas leak, do not use a telephone in the vicinity of the leak. Statement 1039

**Warning**

This unit is intended for installation in restricted access areas. A restricted access area can be accessed only through the use of a special tool, lock and key, or other means of security. Statement 1017

**Warning**

Blank faceplates and cover panels serve three important functions: they prevent exposure to hazardous voltages and currents inside the chassis; they contain electromagnetic interference (EMI) that might disrupt other equipment; and they direct the flow of cooling air through the chassis. Do not operate the system unless all cards, faceplates, front covers, and rear covers are in place. Statement 1029

**Warning**

The covers are an integral part of the safety design of the product. Do not operate the unit without the covers installed. Statement 1077

What You Need to Know

CLI Console Access

Use the USB or RJ-45 console port on the router to access the Cisco Internet Operating System (IOS-XE) command line interface (CLI) on the router and perform configuration tasks. A terminal emulation program is required to establish communication between the router and a PC. See the [“Connecting to a Console Terminal or Modem”](#) section on page 3-25 for instructions.



Note A Microsoft Windows USB driver must be installed before you establish physical connectivity between the router and the PC.

Slot and Port Numbers

The routers have built in ports and new slots. The new slots accommodate new modules and interface cards; SM-Xs, NIMs, ISCs, PVDM4s, and the Cisco E-Series Server Modules. See the [“About Slots and Interfaces”](#) section on page 1-39 for slot and port numbering.

Software Licenses

To use all the features on the router, you must purchase a software package.

See the [“Licensing”](#) section of the *Software Configuration Guide for the Cisco 4400 and Cisco 4300 Series ISRs* for more information.

Before You Begin

Before installing and connecting a Cisco Integrated Services Router, read the safety warnings and gather the following tools and equipment.

- ESD-preventive cord and wrist strap
- Number 2 Phillips screwdriver
- Flat-blade screwdrivers: small, 3/16-in. (4 to 5 mm) and medium, 1/4-in. (6 to 7 mm)
 - To install or remove modules
 - To remove the cover, if you are upgrading memory or other components
- Screws that fit your rack
- Wire crimper
- Wire for connecting the chassis to an earth ground:
 - AWG 6 (13 mm²) wire for NEBS-compliant chassis grounding
 - AWG 14 (2 mm²) or larger wire for NEC-compliant chassis grounding
 - AWG 18 (1 mm²) or larger wire for EN/IEC 60950-compliant chassis grounding
- For NEC-compliant grounding, an appropriate user-supplied ring terminal, with an inner diameter of 1/4 in. (5 to 7 mm)

In addition, depending on the type of modules you plan to use, you might need the following equipment to connect a port to an external network:

- Cables for connection to the WAN and LAN ports (dependent on configuration)



Note For more information on cable specifications, see the [Cisco Modular Access Router Cable Specifications](#) document on Cisco.com.

- Ethernet hub or PC with a network interface card for connection to an Ethernet (LAN) port.
- Console terminal (an ASCII terminal or a PC running HyperTerminal or similar terminal emulation software) configured for 9600 baud, 8 data bits, 1 stop bit, no flow control, and no parity.
- Modem for connection to the auxiliary port for remote administrative access (optional).
- Data service unit (DSU) or channel service unit/data service unit (CSU/DSU) as appropriate for serial interfaces.
- External CSU for any CT1/PRI modules without a built-in CSU.

Unpacking the Router

Do not unpack the router until you are ready to install it. If the final installation site will not be ready for some time, keep the chassis in its shipping container to prevent accidental damage. When you are ready to install the router, proceed with unpacking it.

The router, accessory kit, publications, and any optional equipment you ordered may be shipped in more than one container. When you unpack the containers, check the packing list to ensure that you received all of the items on the list.

Installing the Router

If you need to install modules and FRUs, you can install them either before or after you install the router. Ideally, you install modules when you have the best access to the back panel of the router. Internal modules and FRUs, such as SMs, NIMs or Packet Voice Digital Signal Processor Module (PVDM4s), Compact Flash Cards, and fan trays should be installed before rack-mounting.

There are two methods of installing the router:

- [Rack-Mounting the Chassis, page 3-5](#)
- [Setting the Chassis on a Desktop, page 3-22](#)



Warning

Before working on a system that has an on/off switch, turn OFF the power and unplug the power cord.
Statement 1



Caution

To prevent damage to the chassis, never attempt to lift or tilt the chassis by holding it by the plastic panel on the front. Always hold the chassis by the sides of the metal body.

Rack-Mounting the Chassis

**Warning**

If the rack is provided with stabilizing devices, install the stabilizers before mounting or servicing the unit in the rack. Statement 1006

**Warning**

This equipment must be grounded. Never defeat the ground conductor or operate the equipment in the absence of a suitably installed ground conductor. Contact the appropriate electrical inspection authority or an electrician if you are uncertain that suitable grounding is available. Statement 1024

**Warning**

To prevent the system from overheating, do not operate it in an area that exceeds the maximum recommended ambient temperature of: 40 degrees C. Statement 1047

Cisco ISR4451-Xs can be installed in 19-inch (48.26-cm) EIA and 23-inch (58.42-cm) Southwestern Bell Corporation (SBC) racks. The Cisco ISR4451-Xs can also be mounted in a 600-mm ETSI rack. Use the standard brackets shipped with the router for mounting the chassis in a 19-inch EIA rack; you can order optional larger brackets for mounting the chassis in a 23-inch SBC rack.

You can mount the router in the following ways:

- Center-front mounting—Brackets attached in the center front of the chassis with only the front panel facing forward.
- Center-back mounting—Brackets attached in the center back of the chassis with only the back panel facing forward.
- Front mounting—Brackets attached at the front of the chassis with the front panel facing forward.
- Back mounting—Brackets attached at the back of the chassis with the back panel facing forward.

Attaching Rack-Mount Brackets

Attach the mounting brackets to the router chassis as shown in [Figure 3-1](#) through [Figure 3-4](#), using the screws provided.

**Caution**

Do not over-torque the screws. The recommended torque is 15 to 18 inch-lb (1.7 to 2.0 N-m).

Attach the second bracket to the opposite side of the chassis. Use a number-2 Phillips screwdriver to install the number-8 bracket screws.

**Caution**

Your chassis installation must allow unrestricted airflow for chassis cooling.

Figure 3-1 Bracket Installation for Front Mounting (Cisco ISR4451-X Shown)

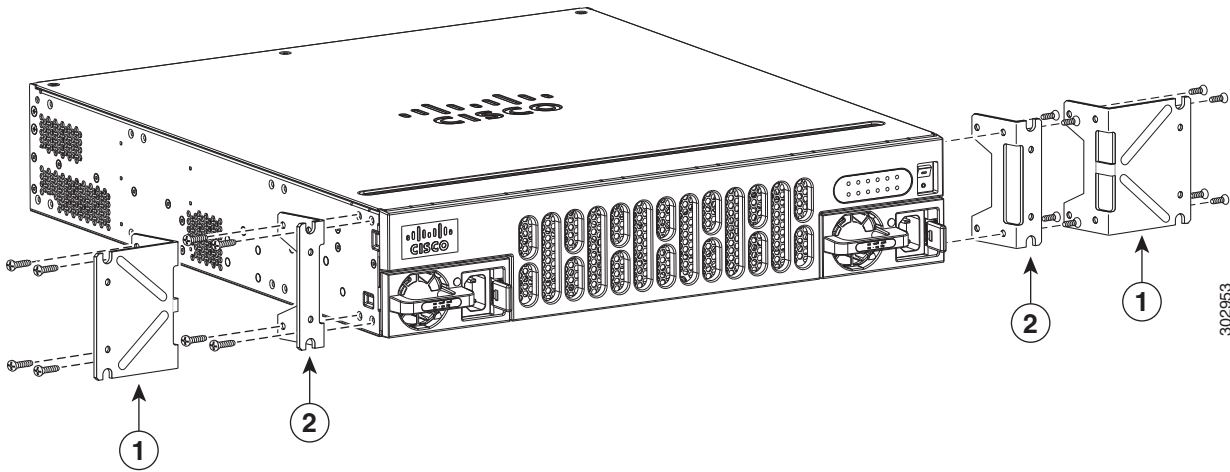

1	23-inch SBC ¹ brackets	2	19-inch EIA brackets
----------	-----------------------------------	----------	----------------------

1. Southwestern Bell Corporation (SBC)

Figure 3-2 Bracket Installation for Center-Front Mounting (Cisco ISR4451-X Shown)

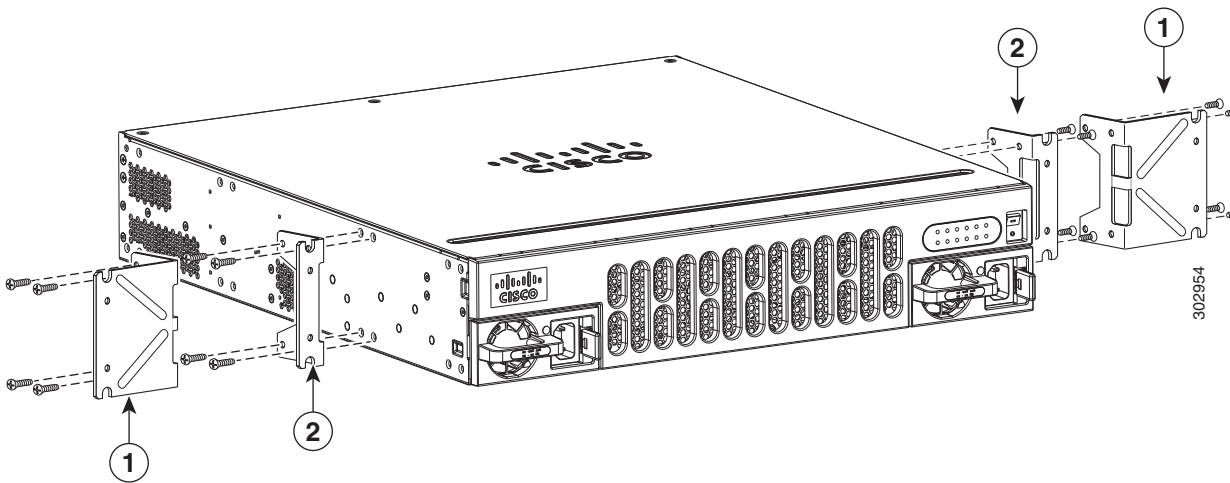

1	23-inch SBC brackets	2	19-inch EIA brackets
----------	----------------------	----------	----------------------

Figure 3-3 Bracket Installation for Back Mounting (Cisco ISR4451-X Shown)

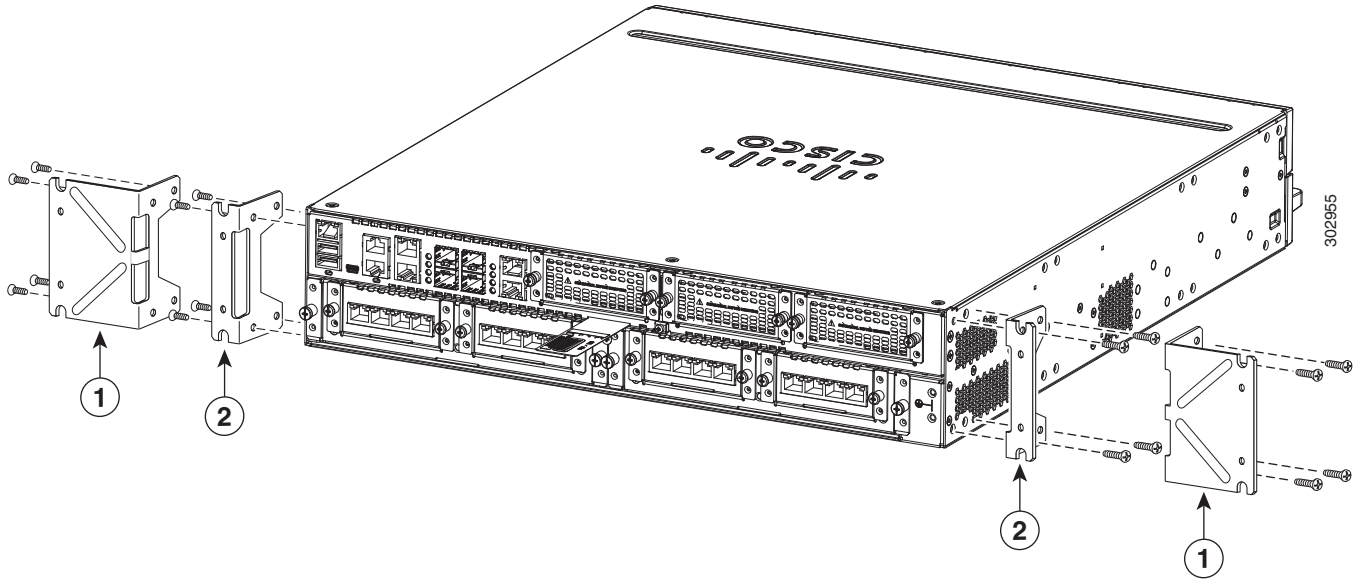

1	23-inch SBC brackets	2	19-inch EIA brackets
---	----------------------	---	----------------------

Figure 3-4 Bracket Installation for Center-Back Mounting (Cisco ISR4451-X Shown)

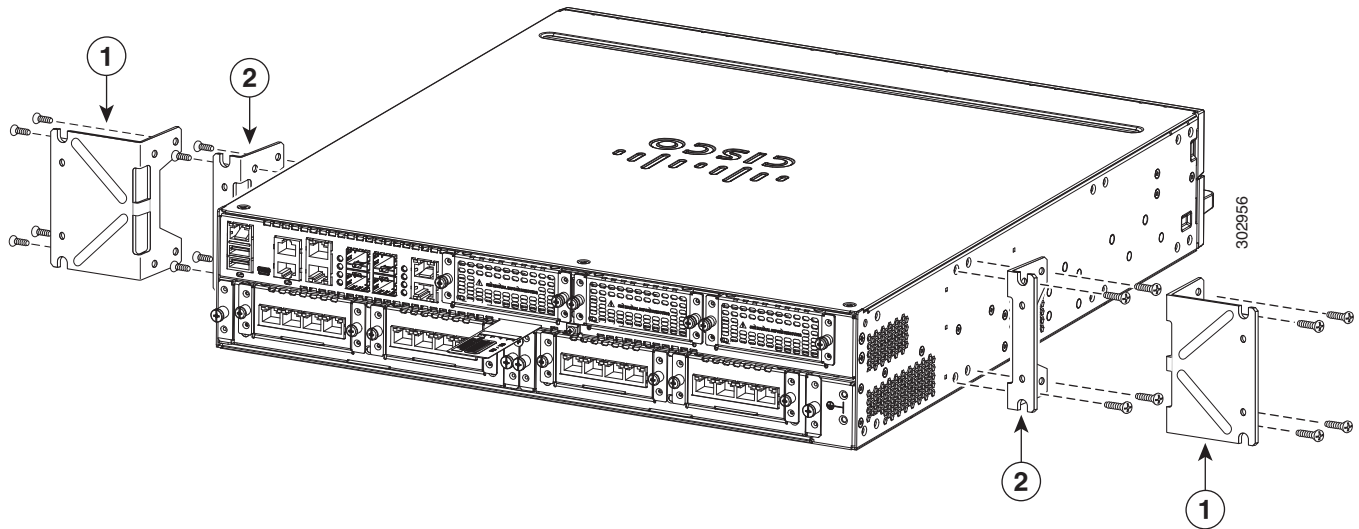

1	23-inch SBC brackets	2	19-inch EIA brackets
---	----------------------	---	----------------------

Mounting the Router in a Rack

After you attach the rack-mount brackets to the router chassis, use the screws provided with the rack to install the chassis in the rack. (See [Figure 3-5](#).)

**Tip**

For both the 19-inch EIA brackets and the 23-inch SBC brackets, start the lower pair of screws first, and rest the brackets on the lower screws while you insert the upper pair of screws.

**Tip**

The screw slots in the brackets are spaced to line up with every *second* pair of screw holes in the rack. When the correct screw holes are used, the small threaded holes in the brackets line up with unused screw holes in the rack. If the small holes do not line up with the rack holes, you must raise or lower the brackets to the next rack hole.

**Warning**

To prevent bodily injury when mounting or servicing this unit in a rack, you must take special precautions to ensure that the system remains stable. The following guidelines are provided to ensure your safety:

- **This unit should be mounted at the bottom of the rack if it is the only unit in the rack.**
 - **When mounting this unit in a partially filled rack, load the rack from the bottom to the top with the heaviest component at the bottom of the rack.**
 - **If the rack is provided with stabilizing devices, install the stabilizers before mounting or servicing the unit in the rack.** Statement 1006
-

**Warning**

To prevent personal injury or damage to the chassis, never attempt to lift or tilt the chassis using the handles on modules (such as power supplies, fans, or cards); these types of handles are not designed to support the weight of the unit. Statement 1032

**Caution**

Be sure to leave space above and below each router in a rack to allow for cooling air circulation.

Figure 3-5 shows a typical installation in a rack.

Figure 3-5 *Mounting the Chassis in a Rack (Typical)*

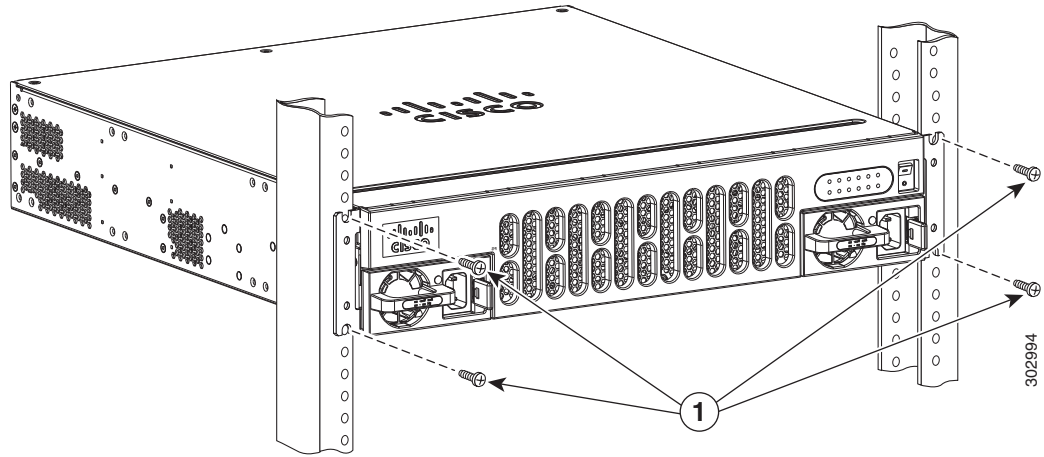

1 Mounting screws (4)

Figure 3-6 shows an installation with a chassis rear-forward.

Figure 3-6 *Mounting the Chassis in a Rack, Rear Forward (Cisco ISR4451-X Shown)*

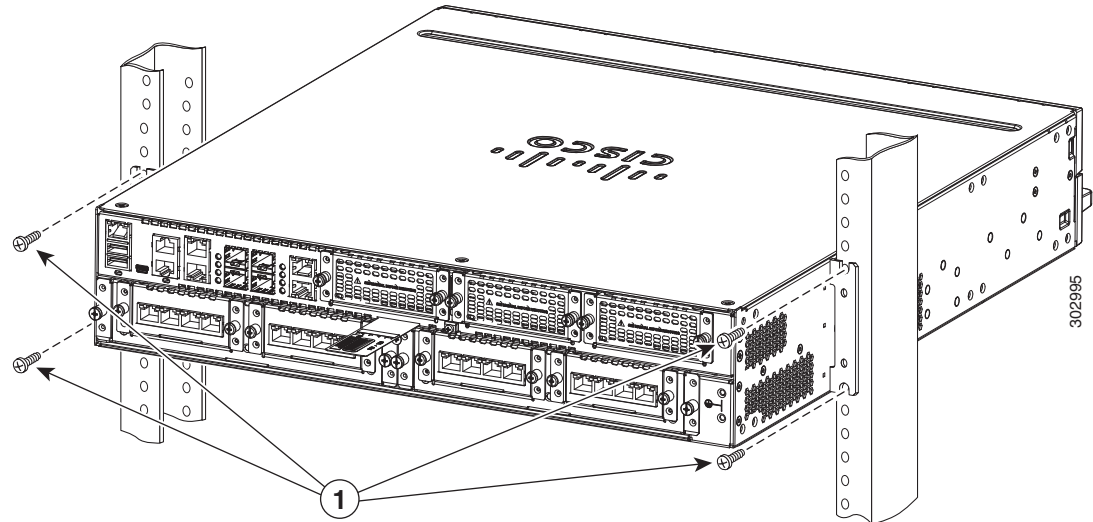

1 Mounting screws (4)

Attaching Wall-Mount Brackets to the Cisco 4431 ISR

Attach the wall-mounting brackets to the router chassis as shown in [Figure 3-7](#) using the four PHMS screws and the plastic spacers provided for each bracket.

**Caution**

Do not over-torque the screws. The recommended torque is 15 to 18 inch-lb (1.7 to 2.0 N-m).

Attaching the Cisco 4431 ISR to a Wall

Attach the router to the wall using the brackets attached in the previous section.

Use the following attaching hardware:

- To attach to a wall stud, each bracket requires one number-10 wood screws (round- or pan-head) with number-10 washers, or two number-10 washer-head screws.

The screws must be long enough to penetrate at least 1.5 inches (38.1 mm) into the supporting wood or metal wall stud.

- For hollow-wall mounting, each bracket requires two wall anchors with washers. Wall anchors and washers must be size number 10.
- Route the cables so that they do not put a strain on the connectors or mounting hardware.

**Caution**

Your chassis installation must allow unrestricted airflow for chassis cooling.

Figure 3-7 Bracket Installation for Wall Mounting (Cisco ISR4431 Shown)

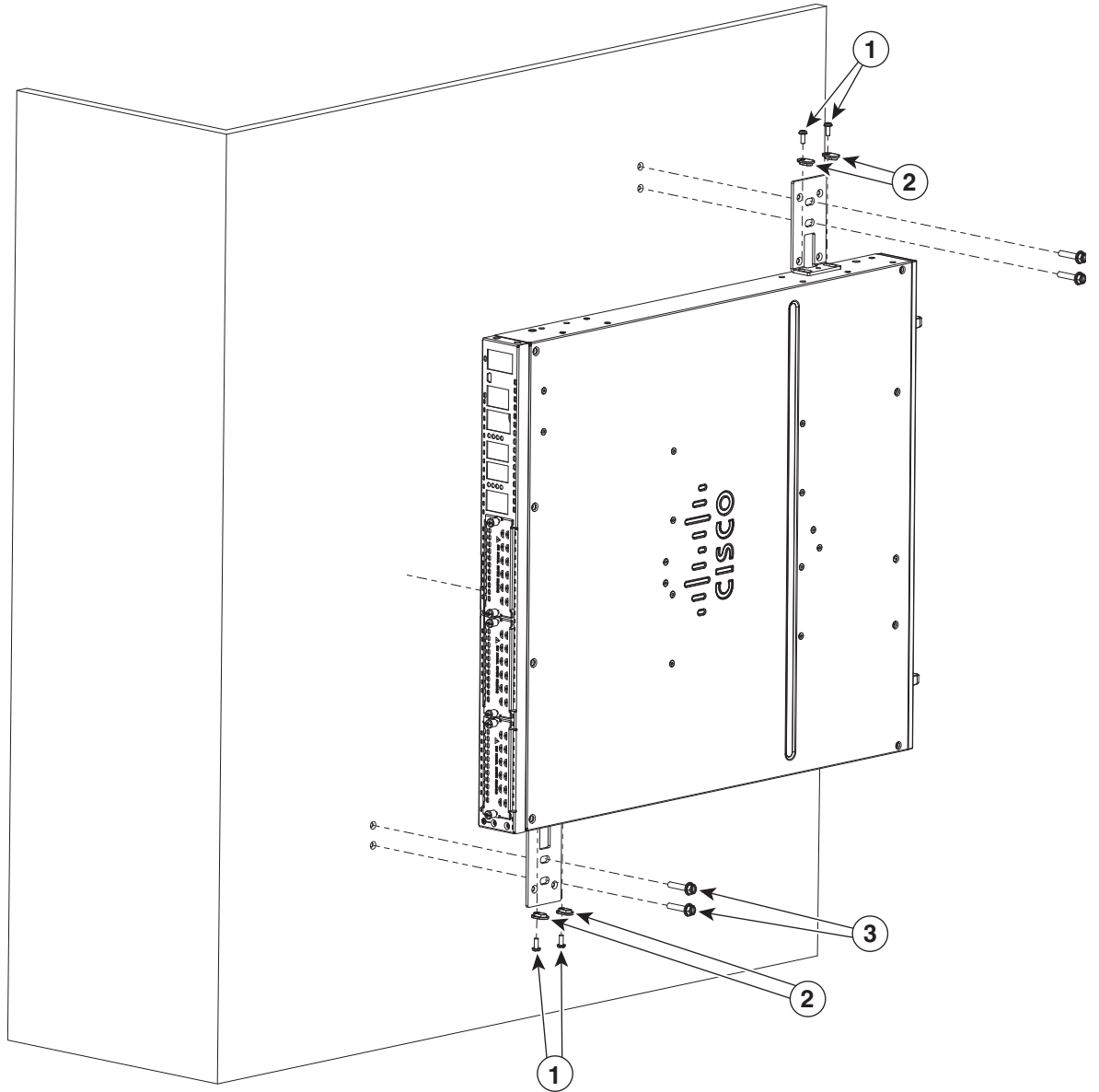

1	Machine screws (included in install kit)	2	Plastic spacers (included)
3	Wall-mounting hardware (customer supplied)		



Note

You can also install it diagonally using the other two sides if you prefer.

Mounting the Cisco 4431 ISR in a Rack

Attach the brackets to the router chassis (towards the front or back) as shown in [Figure 3-8](#) and [Figure 3-9](#).

Figure 3-8 Bracket Installation for Front Mounting (Cisco 4431 ISR Shown)

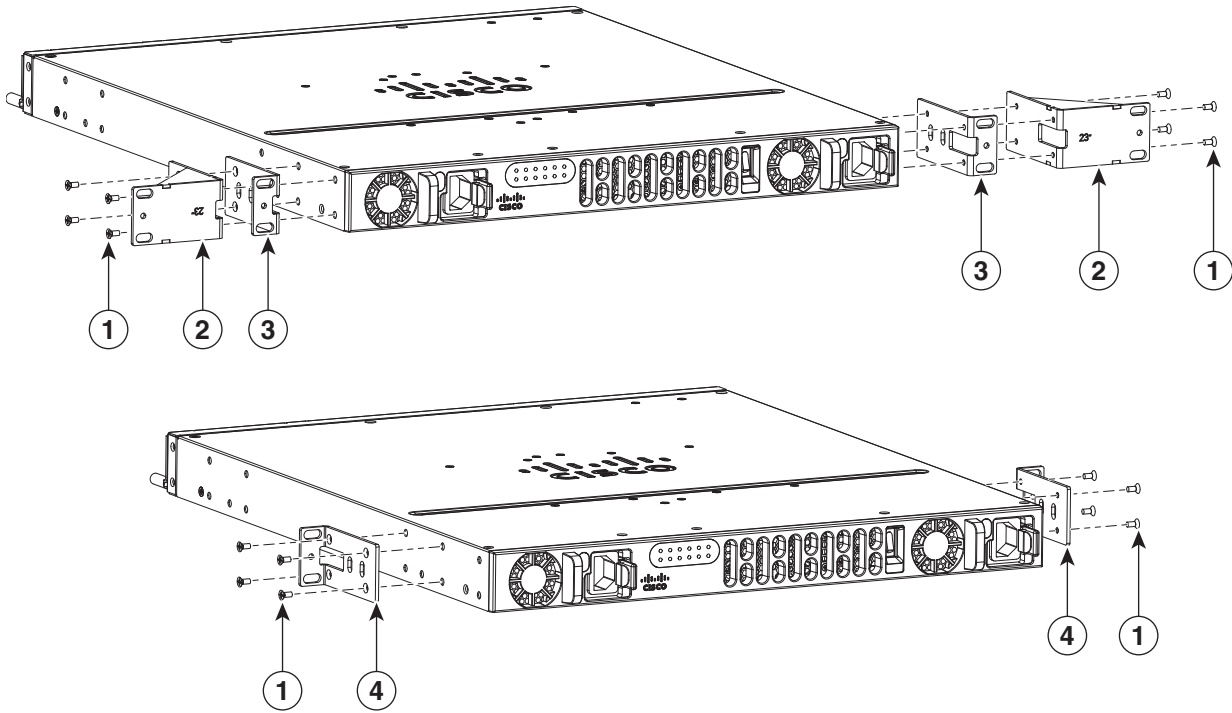

391427

1	Screws	2	23-inch SBC brackets
3	19-inch EIA brackets	4	19-inch EIA brackets

Figure 3-9 Bracket Installation for Back Mounting

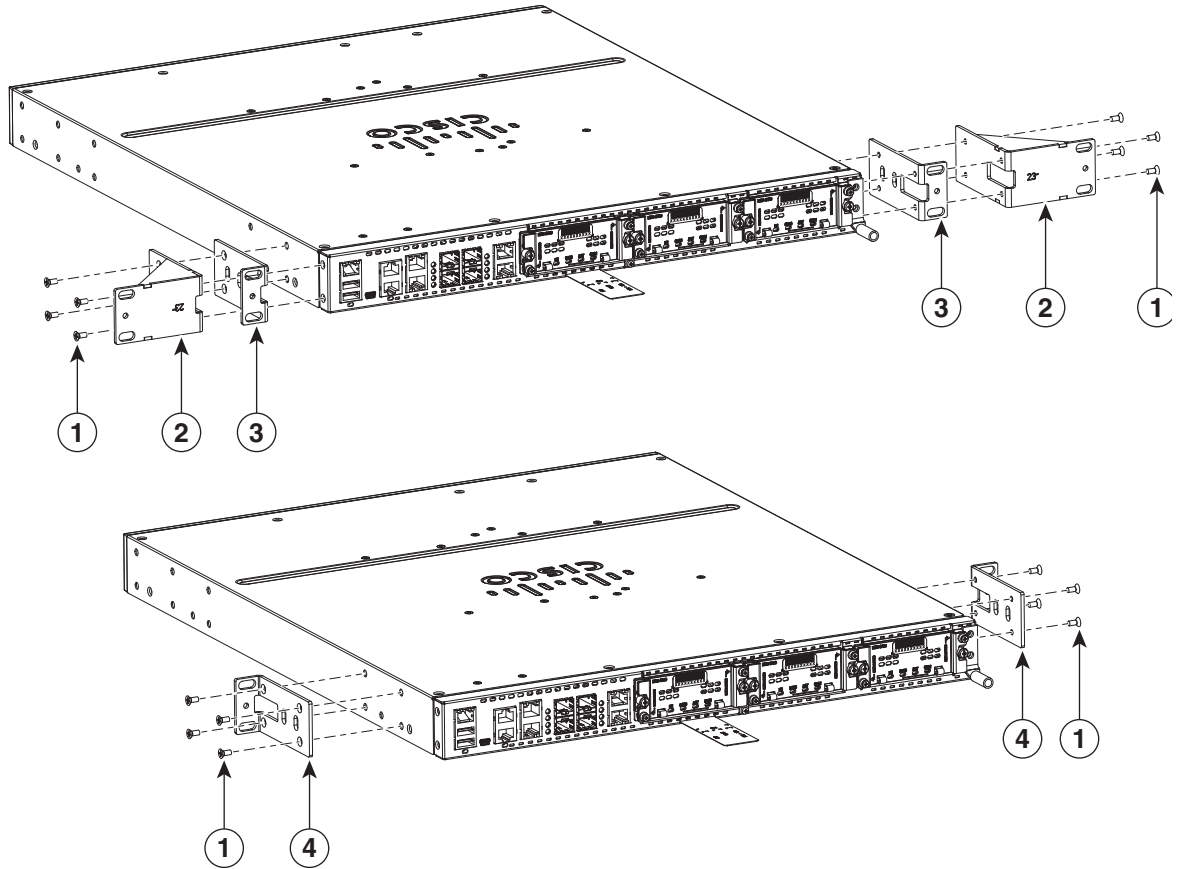

1	Screws	2	23-inch SBC brackets
3	19-inch EIA brackets	4	19-inch EIA brackets

**Tip**

For both the 19-inch EIA brackets and the 23-inch SBC brackets, start the lower pair of screws first, and rest the brackets on the lower screws while you insert the upper pair of screws.

**Tip**

The screw slots in the brackets are spaced to line up with every *second* pair of screw holes in the rack. When the correct screw holes are used, the small threaded holes in the brackets line up with unused screw holes in the rack. If the small holes do not line up with the rack holes, you must raise or lower the brackets to the next rack hole.

**Warning**

To prevent bodily injury when mounting or servicing this unit in a rack, you must take special precautions to ensure that the system remains stable. The following guidelines are provided to ensure your safety:

- This unit should be mounted at the bottom of the rack if it is the only unit in the rack.
 - When mounting this unit in a partially filled rack, load the rack from the bottom to the top with the heaviest component at the bottom of the rack.
 - If the rack is provided with stabilizing devices, install the stabilizers before mounting or servicing the unit in the rack. Statement 1006
-

**Warning**

To prevent personal injury or damage to the chassis, never attempt to lift or tilt the chassis using the handles on modules (such as power supplies, fans, or cards); these types of handles are not designed to support the weight of the unit. Statement 1032

**Caution**

Be sure to leave space above and below each router in a rack to allow for cooling air circulation.

After you attach the rack-mount brackets to the router chassis, use the screws provided with the rack to install the chassis in the rack.

Figure 3-10 shows a typical installation in a rack.

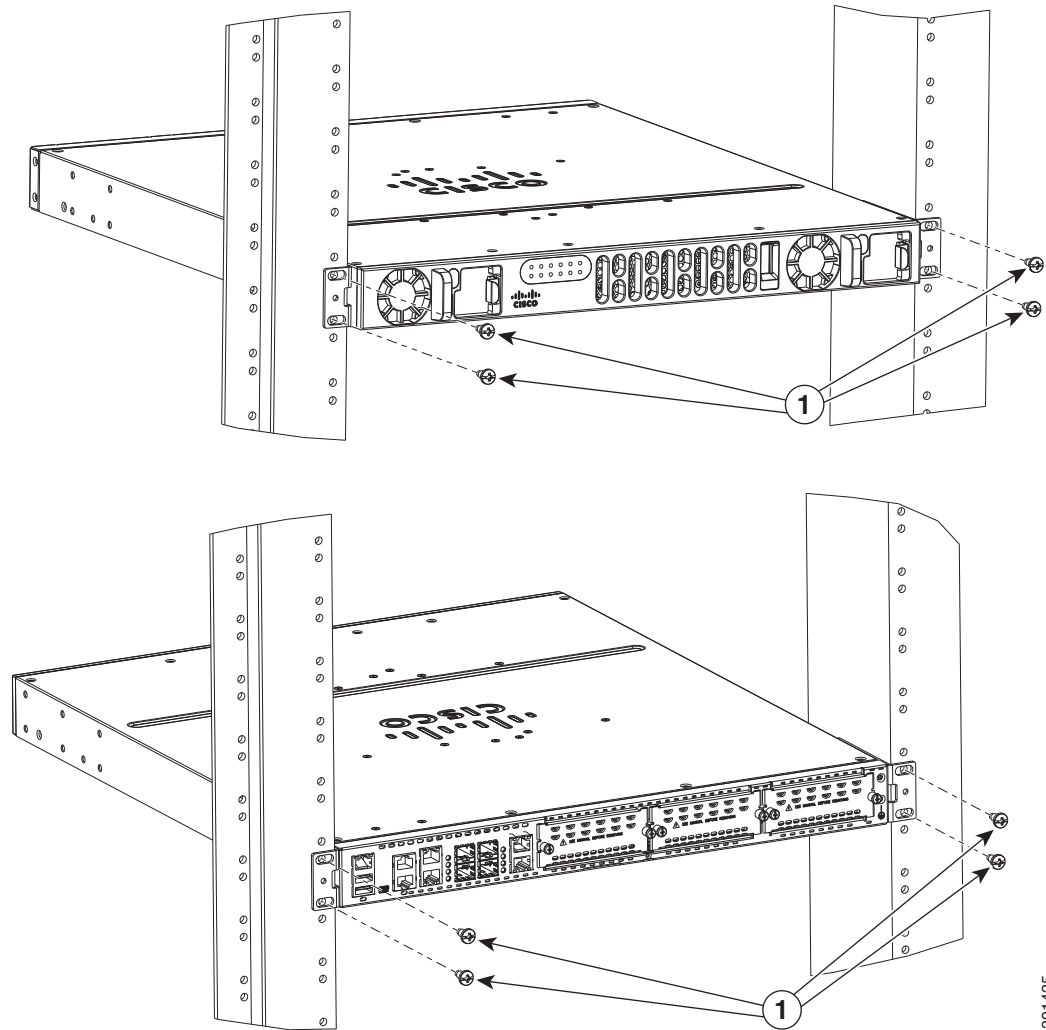
Figure 3-10 Mounting the Cisco 4431 ISR Chassis in a Rack

1	Mounting screws (4)
----------	---------------------

391425

Attaching Wall-Mount Brackets to the Cisco 4221 ISR

Attach the wall-mounting brackets to the router chassis as shown in [Figure 3-11](#) using the four PHMS screws and the plastic spacers provided for each bracket.

**Note**

Do not over-torque the screws. The recommended torque is 15 to 18 inch-lb (1.7 to 2.0 N-m).

Attaching the Cisco 4221 ISR to a Wall

User the following attaching hardware:

- To attach to a wall stud, each bracket requires one number-10 wood screws (round- or pan-head) with number-10 washers, or two number-10 washer-head screws.

- The screws must be long enough to penetrate at least 1.5 inches (38.1 mm) into the supporting wood or metal wall stud.
- For hollow-wall mounting, each bracket requires two wall anchors with washers. Wall anchors and washers must be size number 10.
- Route the cables so that they do not put a strain on the connectors or mounting hardware.

**Note**

Your chassis installation must allow unrestricted airflow for chassis cooling.

Figure 3-11 Bracket Installation for Wall Mounting (Cisco 4221 ISR Shown)

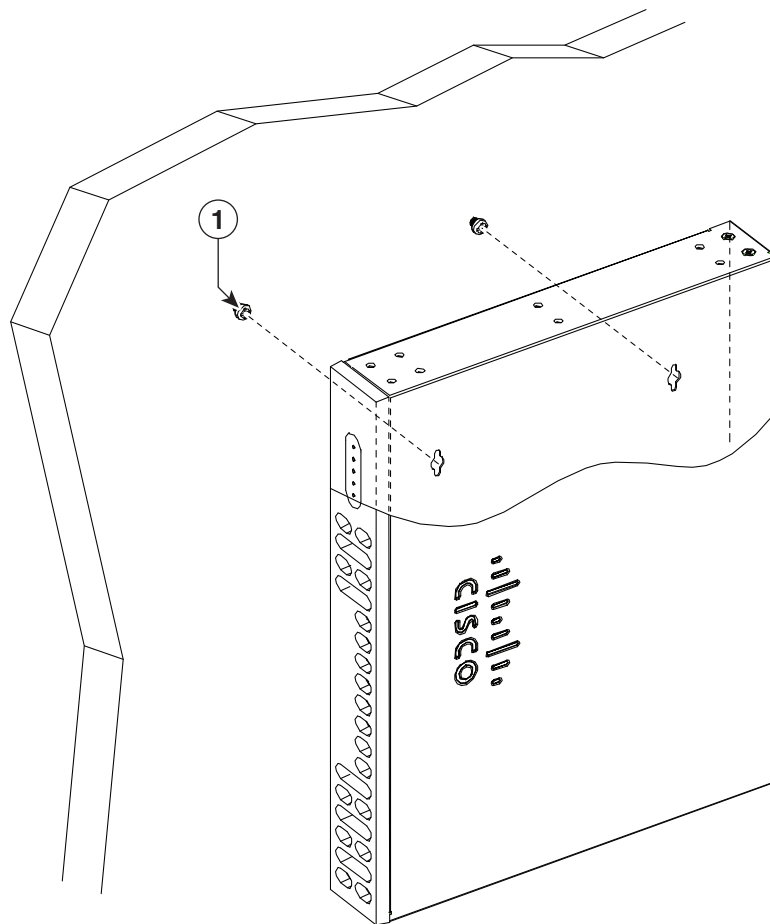

385297

1	Machine screws
---	----------------

Mounting the Cisco 4221 ISR in a Rack

Attach the brackets to the router chassis (towards the front or back) as shown in [Figure 3-12](#) and [Figure 3-13](#).

Figure 3-12 Bracket Installation for Front Mounting (Cisco 4221 ISR Shown)

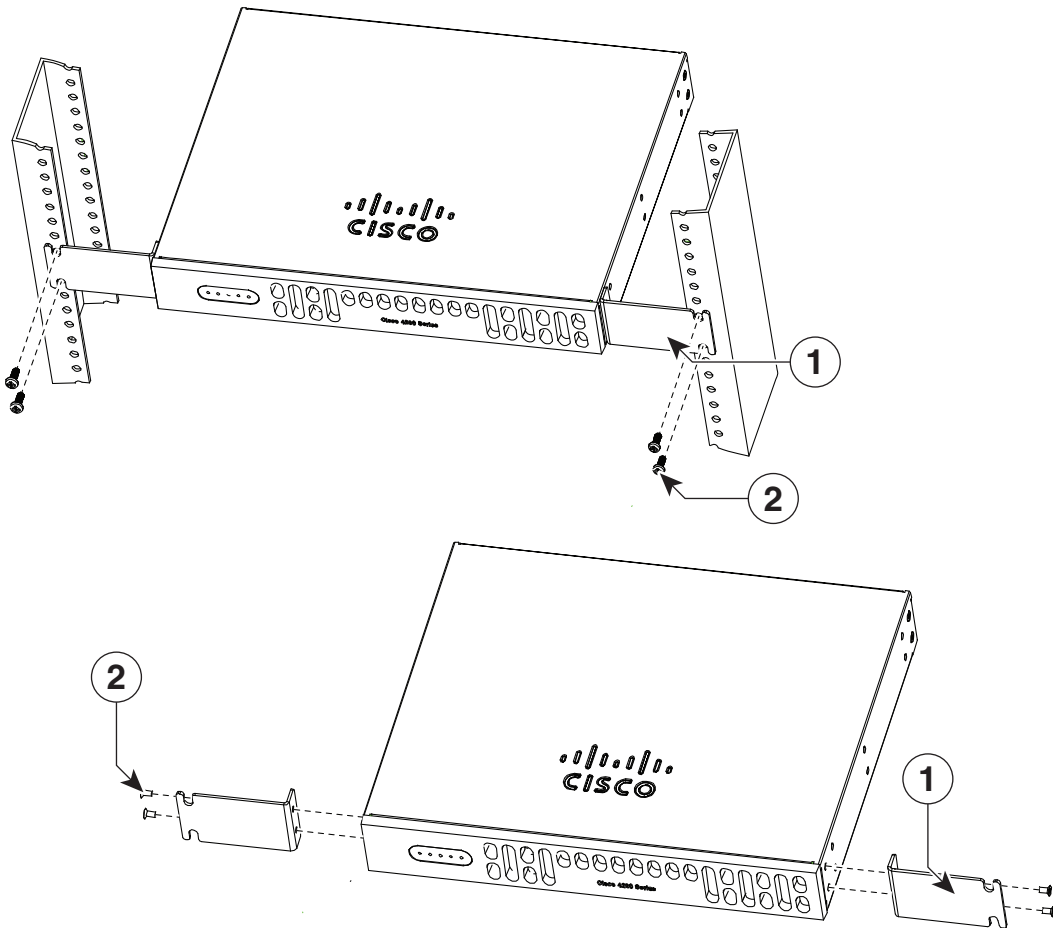

385354

1	Mounting Screws	2	23-inch SBC brackets
---	-----------------	---	----------------------

Figure 3-13 Bracket Installation for Back Mounting

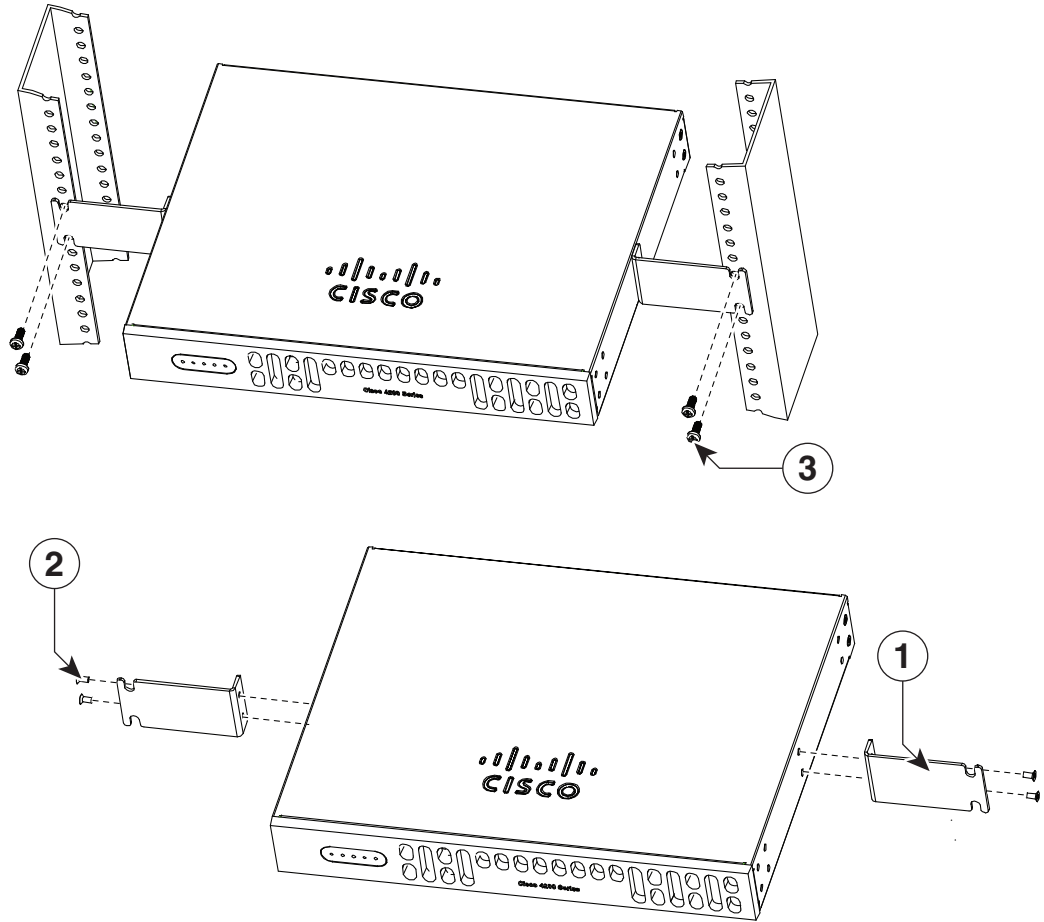

385299

1	Screws	2	23-inch SBC brackets
---	--------	---	----------------------

Mounting the Cisco 4221 ISR in a Rack with the DC Power Unit

Attach the brackets to the router chassis (towards the left or right) as shown in [Figure 3-14](#) and [Figure 3-15](#).

Figure 3-14 DC Power Bracket Installation for Left Mounting (Cisco 4221 ISR Shown)

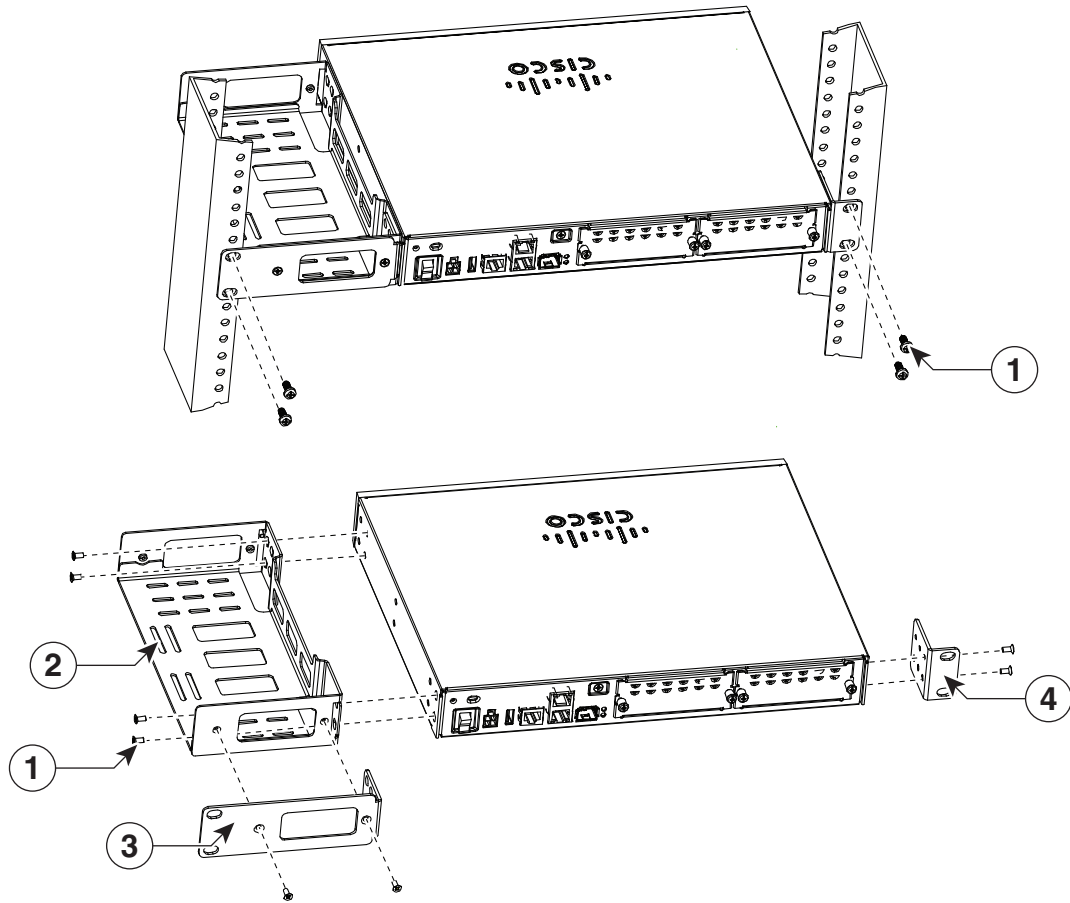

385355

1	Mounting Screws	2	DC power supply unit installation module
3	23-inch SBC brackets	4	19-inch SBC brackets

Figure 3-15 DC Power Bracket Installation for Right Mounting (Cisco 4221 ISR Shown)

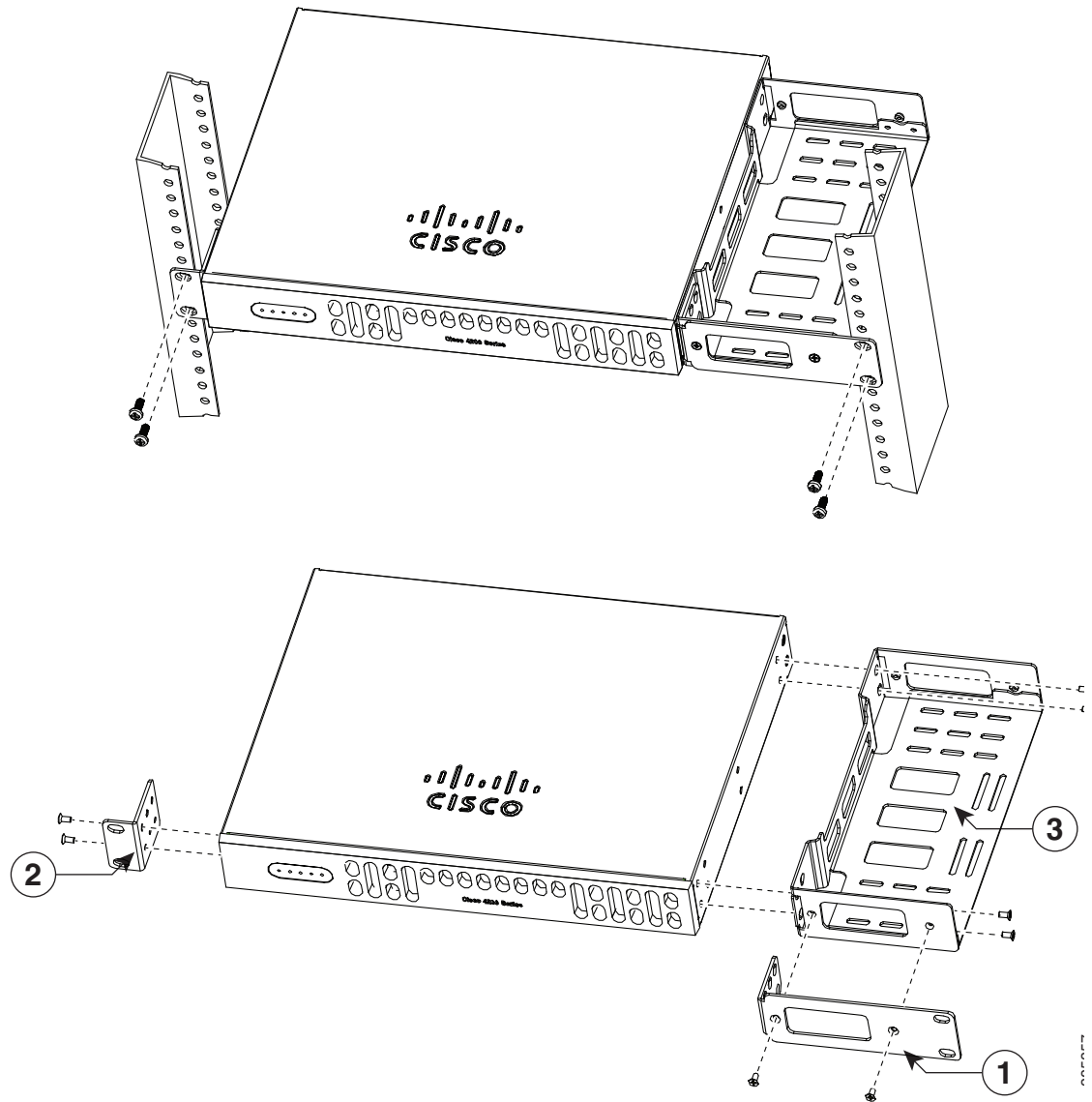

1	23-inch SBC brackets	2	19-inch SBC brackets
3	DC power supply unit installation module		

Grounding the Chassis

After the router is installed, you must connect the chassis to a reliable earth ground. For the chassis ground connection procedures, see the [“Chassis Grounding” section on page 3-22](#).

Setting the Chassis on a Desktop

You can place the router on a desktop, bench top, or shelf.



Note

Do not set the chassis in an area where the high acoustic noise can be an issue.



Warning

To prevent personal injury or damage to the chassis, never attempt to lift or tilt the chassis using the handles on modules (such as power supplies, fans, or cards); these types of handles are not designed to support the weight of the unit. Statement 1032



Caution

Do not place anything on top of the router that weighs more than 10 pounds (4.5 kg), and do not stack routers on a desktop. Excessive distributed weight of more than 10 pounds, or pound point load of 10 pounds on top could damage the chassis.



Caution

Your chassis installation must allow unrestricted airflow for chassis cooling. For placing the router on a desktop, keep at least 1 inch (2.54 cm) of clear space beside the cooling inlet and exhaust vents.

After the router is installed, you must connect the chassis to a reliable earth ground. For the chassis ground connection procedures, see the [“Chassis Grounding” section on page 3-22](#).

Chassis Grounding



Warning

This equipment must be grounded. Never defeat the ground conductor or operate the equipment in the absence of a suitably installed ground conductor. Contact the appropriate electrical inspection authority or an electrician if you are uncertain that suitable grounding is available. Statement 1024



Warning

During this procedure, wear grounding wrist straps to avoid ESD damage to the card. Do not directly touch the backplane with your hand or any metal tool, you could shock yourself. Statement 94

You must connect the chassis to a reliable earth ground; the ground wire must be installed in accordance with local electrical safety standards.

- For grounding, use size 6 AWG (13 mm²) copper wire and the ground lug provided in the accessory kit.



Note

This equipment is suitable for installation in Network Telecommunications Facilities and locations where the NEC applies. The equipment is suitable for installation as part of the Common Bonding Network (CBN).

- For NEC-compliant grounding, use size 14 AWG (2 mm²) or larger copper wire and an appropriate user-supplied ring terminal with an inner diameter of 1/4 in. (5–7 mm).

- For EN/IEC 60950-compliant grounding, use size 18 AWG (1 mm²) or larger copper wire and an appropriate user-supplied ring terminal.

To install the ground connection for your router, perform the following steps:

-
- Step 1** Strip one end of the ground wire to the length required for the ground lug or terminal.
- For the ground lug—approximately 0.75 inch (20 mm)
 - For user-provided ring terminal—as required
- Step 2** Crimp the ground wire to the ground lug or ring terminal, using a crimp tool of the appropriate size.
- Step 3** Attach the ground lug or ring terminal to the chassis as shown in [Figure 3-16](#). For a ground lug, use the two screws with captive locking washers provided. For a ring terminal, use one of the screws provided. Tighten the screws to a torque of 8 to 10 in-lb (0.9 to 1.1 N-m).

Figure 3-16 Chassis Ground Connection on the Router (Cisco ISR4451-X shown) Chassis

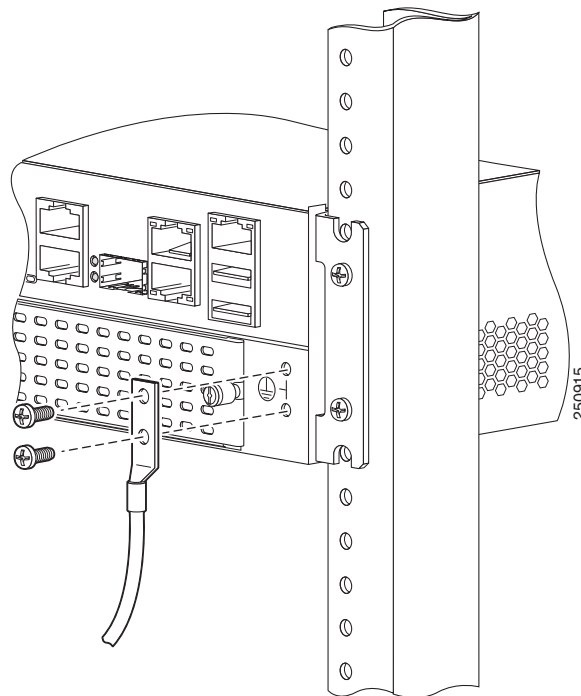

- Step 4** Connect the other end of the ground wire to a known reliable earth ground point at your site.
-

Connecting Power

This section explains how to connect AC power to the router.



Read the installation instructions before connecting the system to the power source. Statement 1004

**Warning**

This unit might have more than one power supply connection. All connections must be removed to de-energize the unit. Statement 1028

**Warning**

Only trained and qualified personnel should be allowed to install, replace, or service this equipment. Statement 1030

**Note**

The installation must comply with all required electrical codes applicable at the installation site.

**Warning**

When installing the product, please use the provided or designated connection cables/power cables/AC adaptors. Using any other cables/adaptors could cause a malfunction or a fire. Electrical Appliance and Material Safety Law prohibits the use of UL-certified cables (that have the "UL" shown on the code) for any other electrical devices than products designated by CISCO. The use of cables that are certified by Electrical Appliance and Material Safety Law (that have "PSE" shown on the code) is not limited to CISCO-designated products. Statement 371.

Connecting to AC Power

If your router uses AC power, connect it to a 15 A, 120 VAC (10 A, 240 VAC) circuit with overcurrent protection.

**Note**

The input voltage tolerance limits for AC power are 90 and 264 VAC.

**Note**

This product requires surge protection to be provided as part of the building installation. To comply with the Telcordia GR-1089 NEBS standard for electromagnetic compatibility and safety, an external surge protective device (SPD) is required at the AC power service equipment.

**Warning**

AC connected units must have a permanent ground connection in addition to the power cable ground wire. NEBS-compliant grounding satisfies this requirement. Statement 284

**Warning**

This product requires short-circuit (overcurrent) protection, to be provided as part of the building installation. Install only in accordance with national and local wiring regulations. Statement 1045

**Warning**

This product relies on the building's installation for short-circuit (overcurrent) protection. Ensure that the protective device is rated not greater than: 15A, 120VAC (16A, 240VAC). Statement 1005

Connecting to a Console Terminal or Modem

The router has asynchronous serial ports and auxiliary ports. These ports provide administrative access to the router either locally (with a console terminal or a PC) or remotely (with a modem). To configure the router through the Cisco IOS CLI, you must establish a connection between the router console port and either a terminal or a PC.

Use the following cables and adapters to establish a local or remote connection.

Table 3-1 Local and Remote Connections

Port Type	Cable	Section
Serial (RJ-45)	EIA RJ-45	Connecting to the Serial Port with Microsoft Windows
Serial (USB)	USB 5-pin mini USB Type-B-to-USB Type-A	
Auxiliary (Modem)	DB-9-to-DB-25	Connecting WAN, LAN, and Voice Interfaces

Connecting to the Serial Port with Microsoft Windows



Note

Install the USB device driver before establishing a physical connection between the router and the PC using the USB Console cable plugged into the USB serial port, otherwise the connection will fail. See the [“Installing the Cisco Microsoft Windows USB Device Driver”](#) section on page 3-27.

Step 1

Connect the end of the console cable with the RJ-45 connector to the light blue console port on the router.

or

Connect a USB 5-pin mini USB Type-B to the USB console port as shown in [Figure 3-17](#). If you are using the USB serial port for the first time on a Windows-based PC, install the USB driver now according to the instructions in the following sections.

- [“Installing the Cisco Microsoft Windows XP USB Driver”](#) section on page 3-28
- [“Installing the Cisco Microsoft Windows 2000 USB Driver”](#) section on page 3-28
- [“Installing the Cisco Microsoft Windows Vista USB Driver”](#) section on page 3-28



Note

You cannot use the USB port and the EIA port concurrently. See [“Connecting WAN, LAN, and Voice Interfaces”](#) section on page 3-30. When the USB port is used it takes priority over the RJ-45 EIA port.

Step 2

Connect the end of the cable with the DB-9 connector (or USB Type-A) to the terminal or PC. If your terminal or PC has a console port that does not accommodate a DB-9 connector, you must provide an appropriate adapter for that port.

Step 3

To communicate with the router, start a terminal emulator application. This software should be configured with the following parameters:

- 9600 baud

- 8 data bits
- no parity
- 1 stop bit
- no flow control

Figure 3-17 Connecting the USB Console Cable to the Router (Shown: Cisco ISR4451-X)

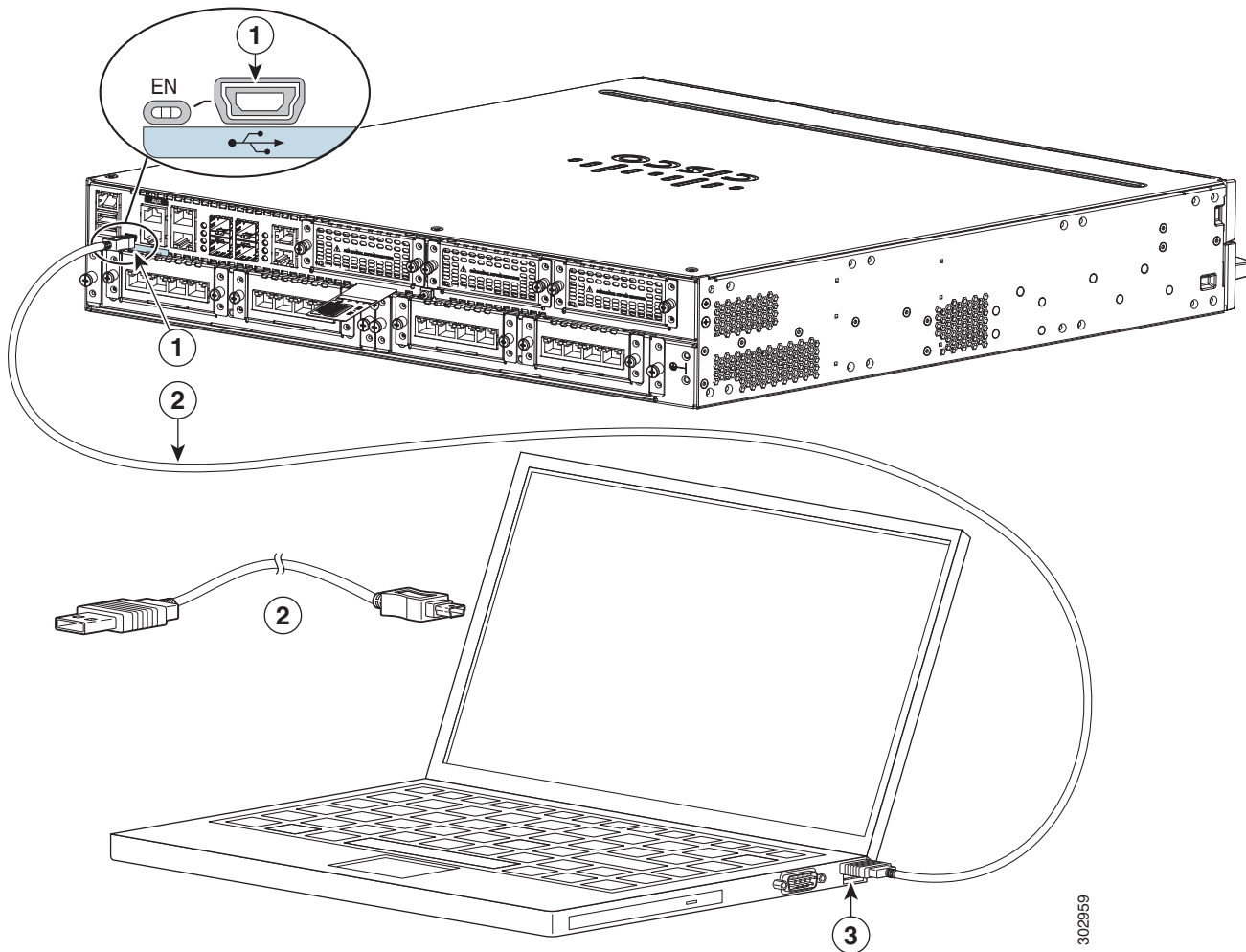

1	USB 5-pin mini USB Type-B console port	2	USB 5-pin mini USB Type-B to USB Type-A console cable
3	USB Type-A		

Connecting to the Console Port with Mac OS X

This procedure describes how to connect a Mac OS X system USB port to the console using the built in OS X Terminal utility.

Step 1 Use the Finder to go to **Applications > Utilities > Terminal**.

Step 2 Connect the OS X USB port to the router.

Step 3 Enter the following commands to find the OS X USB port number

```
macbook:user$ cd /dev
macbook:user$ ls -ltr /dev/*usb*
crw-rw-rw- 1 root  wheel      9,  66 Apr  1 16:46 tty.usbmodem1a21
DT-macbook:dev user$
```

Step 4 Connect to the USB port with the following command followed by the router USB port speed

```
macbook:user$ screen /dev/tty.usbmodem1a21 9600
```

To disconnect the OS X USB console from the Terminal window

Enter **Ctrl-a** followed by **Ctrl-**

Connecting to the Console Port with Linux

This procedure shows how to connect a Linux system USB port to the console using the built in Linux Terminal utility.

Step 1 Open the Linux Terminal window.

Step 2 Connect the Linux USB port to the router.

Step 3 Enter the following commands to find the Linux USB port number

```
root@usb-suse# cd /dev
root@usb-suse /dev# ls -ltr *ACM*
crw-r--r-- 1 root  root      188,  0 Jan 14 18:02 ttyACM0
root@usb-suse /dev#
```

Step 4 Connect to the USB port with the following command followed by the router USB port speed

```
root@usb-suse /dev# screen /dev/ttyACM0 9600
```

To disconnect the Linux USB console from the Terminal window

Enter **Ctrl-a** followed by **:** then **quit**

Installing the Cisco Microsoft Windows USB Device Driver

A USB device driver must be installed the first time a Microsoft Windows-based PC is connected to the USB serial port on the router.

This section contains the following topics:

- [“Installing the Cisco Microsoft Windows XP USB Driver”](#)
- [“Installing the Cisco Microsoft Windows 2000 USB Driver”](#)
- [“Installing the Cisco Microsoft Windows Vista USB Driver”](#)

Installing the Cisco Microsoft Windows XP USB Driver

This procedure shows how to install the Microsoft Windows XP USB driver.

Before you begin, download the appropriate driver for your router model from the Cisco Software Download site, USB Console Software category:

<http://www.cisco.com/cisco/software/navigator.html?mode=prod>

-
- Step 1** Unzip the file Cisco_usbconsole_driver_X_X.zip (where X is a revision number).
 - Step 2** If using 32-bit Windows XP double-click the file setup.exe from the Windows_32 folder, or if using 64-bit Windows XP double-click the file setup(x64).exe from the Windows_64 folder.
 - Step 3** The Cisco Virtual Com InstallShield Wizard begins. Click **Next**.
 - Step 4** The Ready to Install the Program window appears, Click **Install**.
 - Step 5** The InstallShield Wizard Completed window appears. Click **Finish**.
 - Step 6** Connect the USB cable to the PC and router USB console ports. See [Table 3-1](#). The EN LED for the USB console port turns green, and within a few moments the Found New Hardware Wizard appears. Following the instructions to complete the installation of the driver.
 - Step 7** The USB console is ready for use.
-

Installing the Cisco Microsoft Windows 2000 USB Driver

This procedure shows how to install the Microsoft Windows 2000 USB driver.

-
- Step 1** Obtain the file Cisco_usbconsole_driver.zip from the Cisco.com web site and unzip it.
 - Step 2** Double-click the file setup.exe.
 - Step 3** The Cisco Virtual Com InstallShield Wizard begins. Click **Next**.
 - Step 4** The Ready to Install the Program window appears, Click **Install**.
 - Step 5** The InstallShield Wizard Completed window appears. Click **Finish**.
 - Step 6** Connect the USB cable to the PC and router USB console ports. See [Table 3-1](#). The EN LED for the USB console port turns green, and within a few moments a series of Found New Hardware Wizard windows appear. Following the instructions to complete the installation of the driver.
 - Step 7** The USB console is ready for use.
-

Installing the Cisco Microsoft Windows Vista USB Driver

This procedure shows how to install the Microsoft Windows Vista USB driver.

-
- Step 1** Obtain the file Cisco_usbconsole_driver.zip from the Cisco.com web site and unzip it.
 - Step 2** If using 32-bit Windows Vista double-click the file setup.exe from the Windows_32 folder, or if using 64-bit Windows Vista double-click the file setup(x64).exe from the Windows_64 folder.

Step 3 The Cisco Virtual Com InstallShield Wizard begins. Click **Next**.

Step 4 The Ready to Install the Program window appears, Click **Install**.



Note If a User Account Control warning appears, click “Allow - I trust this program...” to proceed.

Step 5 The InstallShield Wizard Completed window appears. Click **Finish**.

Step 6 Connect the USB cable to the PC and router USB console ports. See [Table 3-1](#). The EN LED for the USB console port turns green, and within a few moments a pop up window stating “Installing device driver software” appears. Following the instructions to complete the installation of the driver.

Step 7 The USB console is ready for use.

Uninstalling the Cisco Microsoft Windows USB Driver

This section provides instructions for how to uninstall the Cisco Microsoft Windows USB device driver.

- [“Uninstalling the Cisco Microsoft Windows XP and 2000 USB Driver”](#)
- [“Uninstalling the Cisco Microsoft Windows Vista USB Driver”](#)

Uninstalling the Cisco Microsoft Windows XP and 2000 USB Driver

This procedure shows you how to uninstall both the Microsoft Windows XP and 2000 USB driver. The driver can be removed using the Windows Add Remove Programs utility or the setup.exe program.

Using the Add Remove Programs utility



Note Disconnect the router console terminal before uninstalling the driver.

Step 1 Click **Start** > **Control Panel** > **Add or Remove** Programs.

Step 2 Scroll to Cisco Virtual Com and click **Remove**.

Step 3 When the Program Maintenance window appears, select the **Remove** radio button. Click **Next**.

Using the Setup.exe program



Note Disconnect the router console terminal before uninstalling the driver.

Step 1 Run the setup.exe for Windows 32-bit or setup(x64).exe for Windows-64bit. Click **Next**.

Step 2 The InstallShield Wizard for Cisco Virtual Com appears. Click **Next**.

Step 3 When the Program Maintenance window appears, select the **Remove** radio button. Click **Next**.

Step 4 When the Remove the Program window appears, click **Remove**.

Step 5 When the InstallShield Wizard Completed window appears click **Finish**.

Uninstalling the Cisco Microsoft Windows Vista USB Driver

This procedure shows you how to uninstall the Microsoft Windows Vista USB driver.



Note

Disconnect the router console terminal before uninstalling the driver.

Step 1 Run the setup.exe for Windows 32-bit or setup(x64).exe for Windows-64bit. Click **Next**.

Step 2 The InstallShield Wizard for Cisco Virtual Com appears. Click **Next**.

Step 3 When the Program Maintenance window appears, select the **Remove** radio button. Click **Next**.

Step 4 When the Remove the Program window appears, click **Remove**.



Note

If a User Account Control warning appears, click “Allow - I trust this program...” to proceed.

Step 5 When the InstallShield Wizard Completed window appears click **Finish**.

Connecting WAN, LAN, and Voice Interfaces

This section describes how to connect WAN, LAN, and voice interface cables. It covers the following topics:

- [Ports and Cabling, page 3-32](#)
- [Connection Procedures and Precautions, page 3-32](#)



Warning

Do not work on the system or connect or disconnect cables during periods of lightning activity. Statement 1001



Warning

To avoid electric shock, do not connect safety extra-low voltage (SELV) circuits to telephone-network voltage (TNV) circuits. LAN ports contain SELV circuits, and WAN ports contain TNV circuits. Some LAN and WAN ports both use RJ-45 connectors. Use caution when connecting cables. Statement 1021



Warning

Hazardous network voltages are present in WAN ports regardless of whether power to the unit is OFF or ON. To avoid electric shock, use caution when working near WAN ports. When detaching cables, detach the end away from the unit first. Statement 1026

**Caution**

To comply with the Telcordia GR-1089 NEBS standard for electromagnetic compatibility and safety, connect Gigabit Ethernet ports using RJ-45 connectors for shielded twisted pair cable only to intra-building or unexposed wiring or cable. The intra-building cable must be shielded and the shield must be grounded at both ends. The intra-building port(s) of the equipment or subassembly must not be metallicly connected to interfaces that connect to the OSP or its wiring. These interfaces are designed for use as intra-building interfaces only (Type 2 or Type 4 ports as described in GR-1089-CORE, Issue 4) and require isolation from the exposed OSP cabling. The addition of Primary Protectors is not sufficient protection in order to connect these interfaces metallicly to OSP wiring.

**Warning**

Never install telephone jacks in wet locations unless the jack is specifically designed for wet locations. Statement 1036

**Warning**

Never touch uninsulated telephone wires or terminals unless the telephone line has been disconnected at the network interface. Statement 1037

**Warning**

Class 1 laser product. Statement 1008

Ports and Cabling

Table 3-2 summarizes typical WAN, LAN, and voice connections for routers. The connections summarized here are also described in detail in the document on Cisco.com: [Cisco Modular Access Router Cable Specifications](#)

Table 3-2 WAN, LAN, and Voice Connections

Port or Connection	Port Type, Color ¹	Connection:	Cable
Ethernet	RJ-45, yellow	Ethernet hub or Ethernet switch	Category 5 or higher Ethernet
T1/E1 WAN xCE1T1-PRI	RJ-48C/CA81A RJ-48S, tan	T1 or E1 network External T1 CSU or other T1 equipment	RJ-48 T1/E1 RJ-48S to RJ-48S TE RJ-48S to RJ-48S NT RJ-48S to RJ-48S T1 RJ-48S to bare RJ-48S to BNC RJ-48S to twinaxial cable RJ-48S to DB-15 RJ-48S to DB-15 null
T3/DS3/E3 WAN	BNC connector	T3 network, CSU/DSU, or other T3/DS3 equipment	75-ohm coaxial cable
Cisco serial	60-pin D-sub, blue	CSU/DSU and serial network or equipment	Cisco serial transition cable that matches the signaling protocol (EIA/TIA-232, EIA/TIA-449, V.35, X.21, or EIA-530) and the serial port operating mode (DTE or DCE). ²
Cisco Smart serial	Cisco Smart compact connector, blue	CSU/DSU and serial network or equipment	
T1/E1 digital voice	RJ-48C/CA81A, tan	Digital PBX, ISDN network, CSU/DSU	RJ-48 T1/E1
Gigabit Ethernet SFP, optical	LC, color according to optical wavelength	1000BASE-SX, -LX, -LH, -ZX, -CWDM	Optical fiber as specified on applicable data sheet
Gigabit Ethernet SFP, copper	RJ-45	1000BASE-T	Category 5, 5e, 6 UTP

1. Cable color codes are specific to Cisco cables.

2. See the [Cisco Modular Access Router Cable Specifications](#) document for information about choosing these cables.

Connection Procedures and Precautions

- Connect each WAN, LAN, and voice cable to the appropriate connector on the chassis or on a network module or interface card.

- Position the cables carefully, so that they do not put strain on the connectors.
- Organize cables in bundles so that cables do not intertwine.
- Inspect the cables to make sure that the routing and bend radius is satisfactory. Reposition cables, if necessary.
- Install cable ties in accordance with site requirements.

For cable pinouts, see [Cisco Modular Access Router Cable Specifications](#).



Initial Configuration

This chapter describes how to perform the initial configuration on the router after you have installed and connected it. It contains the following sections:

- [Performing the Initial Configuration on the Router, page 4-1](#)
 - [Using Cisco Setup Command Facility, page 4-1](#)
 - [Using Cisco IOS XE CLI—Manual Configuration, page 4-5](#)
- [Verifying the Initial Configuration, page 4-23](#)

Performing the Initial Configuration on the Router

You can perform initial configuration on the router with the help of the following tools:

- [Using Cisco Setup Command Facility](#)
- [Using Cisco IOS XE CLI—Manual Configuration](#)

Using Cisco Setup Command Facility

The setup command facility prompts you to enter the information that is needed to configure a router quickly. The facility steps you through a initial configuration, including LAN and WAN interfaces. For more general information about the setup command facility, see the following document:

Cisco IOS Configuration Fundamentals Configuration Guide, Release 12.4, Part 2: Cisco IOS User Interfaces: Using AutoInstall and Setup:
<http://www.cisco.com/c/en/us/support/ios-nx-os-software/ios-xe-3s/products-installation-and-configuration-guides-list.html>

This section explains how to configure a hostname for the router, set passwords, and configure an interface to communicate with the management network.



Note

The messages that are displayed will vary based on your router model, the installed interface modules, and the software image. The following example and the user entries (in bold) are shown as examples only.

**Note**

If you make a mistake while using the setup command facility, you can exit and run the setup command facility again. Press **Ctrl-C**, and enter the **setup** command in privileged EXEC mode (Router#).

Step 1 From the Cisco IOS-XE CLI, enter the **setup** command in privileged EXEC mode:

```
Router> enable
Password: <password>
Router# setup

      --- System Configuration Dialog ---
Continue with configuration dialog? [yes/no]:
```

You are now in the Setup Configuration Utility.

The prompts in the setup command facility vary; depending on your router model, on the installed interface modules, and on the software image. The following steps and the user entries (in bold) are shown as examples only.

**Note**

This setup command facility is also entered automatically if there is no configuration on the router when it is booted into Cisco IOS-XE.

**Note**

If you make a mistake while using the setup command facility, you can exit and run the setup command facility again. Press **Ctrl-C**, and enter the **setup** command at the privileged EXEC mode prompt (Router#). For more information on using the setup command facility, see *The Setup Command* chapter in *Cisco IOS Configuration Fundamentals Command Reference*, Release 12.2T, at the following URL:
http://www.cisco.com/en/US/docs/ios/12_2t/fun/command/reference/122tfr.html

Step 2 To proceed using the setup command facility, enter **yes**.

```
Continue with configuration dialog? [yes/no]:

At any point you may enter a question mark '?' for help.

Use ctrl-c to abort configuration dialog at any prompt.
Default settings are in square brackets '[]'.
```

Step 3 Basic management setup configures only enough connectivity

```
Would you like to enter basic management setup? [yes/no]: yes
```

Step 4 Enter a hostname for the router (this example uses myrouter):

```
Configuring global parameters:
Enter host name [Router]: myrouter
```

Step 5 Enter an enable secret password. This password is encrypted (for more security) and cannot be seen when viewing the configuration.

```
The enable secret is a password used to protect access to
privileged EXEC and configuration modes. This password, after
entered, becomes encrypted in the configuration.
Enter enable secret: cisco
```

- Step 6** Enter an enable password that is different from the enable secret password. This password is *not* encrypted (and is less secure) and can be seen when viewing the configuration.

The enable password is used when you do not specify an enable secret password, with some older software versions, and some boot images.

Enter enable password: **cisco123**

- Step 7** Enter the virtual terminal password, which prevents unauthenticated access to the router through ports other than the console port:

The virtual terminal password is used to protect access to the router over a network interface.

Enter virtual terminal password: **cisco**

- Step 8** Respond to the following prompts as appropriate for your network:

```
Configure SNMP Network Management? [no]: yes
Community string [public]:
```

A summary of the available interfaces is displayed.



Note The interface summary includes interface numbering, which is dependent on the router model and the installed modules and interface cards.

Current interface summary

Interface	IP-Address	OK?	Method	Status	Protocol
GigabitEthernet0/0/0	unassigned	YES	NVRAM	administratively down	down
GigabitEthernet0/1/0	10.10.10.12	YES	DHCP	up	up
GigabitEthernet0/2/0	unassigned	YES	NVRAM	administratively down	down
SSLVPN-VIF0	unassigned	NO	unset	up	

Any interface listed with OK? value "NO" does not have a valid configuration

- Step 9** Respond to the following prompts as appropriate for your network:

```
Configuring interface GigabitEthernet0/1/0:
Configure IP on this interface? [yes]: yes
IP address for this interface [10.10.10.12]:
Subnet mask for this interface [255.0.0.0] : 255.255.255.0
Class A network is 10.0.0.0, 24 subnet bits; mask is /24
```

The following configuration command script was created:

```
hostname myrouter
enable secret 5 $1$t/Dj$yAeGKviLLZNOBX0b9eif00 enable password cisco123 line vty 0 4
password cisco snmp-server community public !
no ip routing

!
interface GigabitEthernet0/0/0
shutdown
no ip address
!
interface GigabitEthernet0/1/0
no shutdown
ip address 10.10.10.12 255.255.255.0
!
interface GigabitEthernet0/2/0
shutdown
```

```
no ip address
!
end
```

Step 10 Respond to the following prompts. Select [2] to save the initial configuration:

```
[0] Go to the IOS command prompt without saving this config.
[1] Return back to the setup without saving this config.
[2] Save this configuration to nvram and exit.
```

```
Enter your selection [2]: 2
Building configuration...
Use the enabled mode 'configure' command to modify this configuration.
```

```
Press RETURN to get started! RETURN
```

The user prompt is displayed:

```
myrouter>
```

Completing the Configuration

When using the Cisco Setup, and after you have provided all the information requested by the facility, the final configuration appears. To complete your router configuration, follow these steps:

Step 1 The facility prompts you to save the configuration.

- If you answer no, the configuration information you entered is *not* saved, and you return to the router enable prompt (Router#). Enter **setup** to return to the System Configuration Dialog.
- If you answer yes, the configuration is saved, and you are returned to the user EXEC prompt (Router>).

```
Use this configuration? {yes/no} : yes
Building configuration...
Use the enabled mode 'configure' command to modify this configuration.
```

```
Press RETURN to get started!
```

```
%LINK-3-UPDOWN: Interface Ethernet0/0, changed state to up
%LINK-3-UPDOWN: Interface Ethernet0/1, changed state to up
%LINK-3-UPDOWN: Interface Serial0/0/0, changed state to up
%LINK-3-UPDOWN: Interface Serial0/0/1, changed state to down
%LINK-3-UPDOWN: Interface Serial0/2, changed state to down
%LINK-3-UPDOWN: Interface Serial1/0, changed state to up
%LINK-3-UPDOWN: Interface Serial1/1, changed state to down
%LINK-3-UPDOWN: Interface Serial1/2, changed state to down
```

```
<Additional messages omitted.>
```

Step 2 When the messages stop appearing on your screen, press **Return** to get the Router> prompt.

Step 3 The Router> prompt indicates that you are now at the command-line interface (CLI) and you have just completed a initial router configuration. Nevertheless, this is *not* a complete configuration. At this point, you have two choices:

- Run the setup command facility again, and create another configuration.

```
Router> enable
Password: password
Router# setup
```

- Modify the existing configuration or configure additional features by using the CLI:

```
Router> enable
Password: password
Router# configure terminal
Router(config)#
```

Using Cisco IOS XE CLI—Manual Configuration

This section shows you how to access the command-line interface (CLI) to perform the initial configuration on the router.

If the system configuration dialog message does not appear, a default configuration file was installed on the router prior to shipping. Follow these steps to configure the router.

- Step 1** Enter the following answer when the system message appears on the router.

```
--- System Configuration Dialog ---
```

```
At any point you may enter a question mark '?' for help.
Use ctrl-c to abort configuration dialog at any prompt.
Default settings are in square brackets '['].
```

```
Would you like to enter the initial configuration dialog? [yes/no]: no
```

- Step 2** Press **Return** to terminate autoinstall and continue with manual configuration:

```
Would you like to terminate autoinstall? [yes] Return
```

Several messages are displayed, ending with a line similar to the following:

```
...
Copyright (c) 1986-2012 by cisco Systems, Inc.
Compiled <date> <time> by <person>
```

- Step 3** Press **Return** to bring up the Router> prompt.

```
...
flashfs[4]: Initialization complete.
Router>
```

- Step 4** Type **enable** to enter privileged EXEC mode:

```
Router> enable
Router#
```

- [Configuring the Router Hostname, page 4-6](#) (Optional)
- [Configuring the Enable and Enable Secret Passwords, page 4-7](#) (Required)
- [Configuring the Console Idle Privileged EXEC Timeout, page 4-8](#) (Optional)
- [Gigabit Ethernet Management Interface Overview, page 4-10](#) (Required)
- [Specifying a Default Route or Gateway of Last Resort, page 4-12](#) (Required)

- [Configuring IP Routing and IP Protocols, page 4-13](#) (Required)
- [Configuring Virtual Terminal Lines for Remote Console Access, page 4-16](#) (Required)
- [Configuring the Auxiliary Line, page 4-18](#) (Optional)
- [Verifying Network Connectivity, page 4-19](#) (Required)
- [Saving Your Router Configuration, page 4-20](#) (Required)
- [Saving Backup Copies of Configuration and System Image, page 4-20](#) (Optional)

Configuring the Router Hostname

The hostname is used in CLI prompts and default configuration filenames. If you do not configure the router hostname, the router uses the factory-assigned default hostname “Router.”

SUMMARY STEPS

1. **enable**
2. **configure terminal**
3. **hostname *name***
4. Verify that the router prompt displays your new hostname.
5. **end**

DETAILED STEPS

	Command or Action	Purpose
Step 1	enable Example: Router> enable	Enables privileged EXEC mode. <ul style="list-style-type: none"> • Enter your password if prompted.
Step 2	configure terminal Example: Router# configure terminal	Enters global configuration mode.
Step 3	hostname <i>name</i> Example: Router(config)# hostname myrouter	Specifies or modifies the hostname for the network server.
Step 4	Verify that the router prompt displays your new hostname. Example: myrouter(config)#	—
Step 5	end Example: myrouter# end	(Optional) Returns to privileged EXEC mode.

Configuring the Enable and Enable Secret Passwords

To provide an additional layer of security, particularly for passwords that cross the network or are stored on a TFTP server, you can use either the **enable password** command or **enable secret** command. Both commands accomplish the same thing—they allow you to establish an encrypted password that users must enter to access privileged EXEC (enable) mode.

We recommend that you use the **enable secret** command because it uses an improved encryption algorithm. Use the **enable password** command only if you boot an older image of the Cisco IOS XE software.

For more information, see the “Configuring Passwords and Privileges” chapter in the *Cisco IOS Security Configuration Guide*. Also see the *Cisco IOS Password Encryption Facts* tech note and the *Improving Security on Cisco Routers* tech note.

Restrictions

If you configure the **enable secret** command, it takes precedence over the **enable password** command; the two commands cannot be in effect simultaneously.

SUMMARY STEPS

1. **enable**
2. **configure terminal**
3. **enable password** *password*
4. **enable secret** *password*
5. **end**
6. **enable**
7. **end**

DETAILED STEPS

	Command or Action	Purpose
Step 1	enable Example: Router> enable	Enables privileged EXEC mode. <ul style="list-style-type: none"> • Enter your password if prompted.
Step 2	configure terminal Example: Router# configure terminal	Enters global configuration mode.
Step 3	enable password <i>password</i> Example: Router(config)# enable password pswd2	(Optional) Sets a local password to control access to various privilege levels. <ul style="list-style-type: none"> • We recommend that you perform this step only if you boot an older image of the Cisco IOS-XE software or if you boot older boot ROMs that do not recognize the enable secret command.

	Command or Action	Purpose
Step 4	enable secret <i>password</i> Example: Router(config)# enable secret <i>greentree</i>	Specifies an additional layer of security over the enable password command. <ul style="list-style-type: none"> Do not use the same password that you entered in Step 3.
Step 5	end Example: Router(config)# end	Returns to privileged EXEC mode.
Step 6	enable Example: Router> enable	Enables privileged EXEC mode. <ul style="list-style-type: none"> Verify that your new enable or enable secret password works.
Step 7	end Example: Router(config)# end	(Optional) Returns to privileged EXEC mode.

Configuring the Console Idle Privileged EXEC Timeout

This section describes how to configure the console line's idle privileged EXEC timeout. By default, the privileged EXEC command interpreter waits 10 minutes to detect user input before timing out.

When you configure the console line, you can also set communication parameters, specify autobaud connections, and configure terminal operating parameters for the terminal that you are using. For more information on configuring the console line, see the *Cisco IOS Configuration Fundamentals and Network Management Configuration Guide*. In particular, see the “Configuring Operating Characteristics for Terminals” and “Troubleshooting and Fault Management” chapters.

SUMMARY STEPS

- enable**
- configure terminal**
- line console 0**
- exec-timeout** *minutes* [*seconds*]
- end**
- show running-config**

DETAILED STEPS

	Command or Action	Purpose
Step 1	enable Example: Router> enable	Enables privileged EXEC mode. <ul style="list-style-type: none"> Enter your password if prompted.
Step 2	configure terminal Example: Router# configure terminal	Enters global configuration mode.
Step 3	line console 0 Example: Router(config)# line console 0	Configures the console line and starts the line configuration command collection mode.
Step 4	exec-timeout minutes [seconds] Example: Router(config-line)# exec-timeout 0 0	Sets the idle privileged EXEC timeout, which is the interval that the privileged EXEC command interpreter waits until user input is detected. <ul style="list-style-type: none"> The example shows how to specify no timeout. Setting the exec-timeout value to 0 will cause the router to never log out once logged in. This could have security implications if you leave the console without manually logging out using the disable command.
Step 5	end Example: Router(config)# end	Returns to privileged EXEC mode.
Step 6	show running-config Example: Router(config)# show running-config	Displays the running configuration file. <ul style="list-style-type: none"> Verify that you properly configured the idle privileged EXEC timeout.

Examples

The following example shows how to set the console idle privileged EXEC timeout to 2 minutes 30 seconds:

```
line console
  exec-timeout 2 30
```

The following example shows how to set the console idle privileged EXEC timeout to 30 seconds:

```
line console
  exec-timeout 0 30
```

Gigabit Ethernet Management Interface Overview

The router provides an Ethernet management port, named GigabitEthernet0.

The purpose of this interface is to allow users to perform management tasks on the router; it is an interface that should not and often cannot forward network traffic but can be used to access the router via Telnet and SSH to perform management tasks on the router. The interface is most useful before a router has begun routing, or in troubleshooting scenarios when other forwarding interfaces are inactive.

The following aspects of the management ethernet interface should be noted:

- The router has one management ethernet interface named GigabitEthernet0.
- IPv4, IPv6, and ARP are the only routed protocols supported for the interface.
- The interface provides a way to access to the router even if forwarding interfaces are not functional, or the IOS process is down.
- The management ethernet interface is part of its own VRF. See the “Management Ethernet Interface VRF” section in the *Software Configuration Guide for the Cisco 4400 and Cisco 4300 Series ISRs* for more details.

Default Gigabit Ethernet Configuration

By default, a forwarding VRF is configured for the interface with a special group named “Mgmt-intf.” This cannot be changed. This isolates the traffic on the management interface away from the forwarding plane. Basic configuration is like other interfaces, however, there are many forwarding features not supported on these interfaces. No forwarding features can be configured on GigabitEthernet0 interface as it is only used for management.

For example, the default configuration is as follows:

```
interface GigabitEthernet0
vrf forwarding Mgmt-intf
ip address 172.18.77.212 255.255.255.240
negotiation auto
```

Gigabit Ethernet Port Numbering

The Gigabit Ethernet Management port is always GigabitEthernet0.

The port can be accessed in configuration mode.

```
Router# config t
Enter configuration commands, one per line. End with CNTL/Z.
Router(config)#interface gigabitethernet0
Router(config-if)#
```

Configuring Gigabit Ethernet Interfaces

This sections shows how to assign an IP address and interface description to an Ethernet interface on your router.

For comprehensive configuration information on Gigabit Ethernet interfaces, see the “Configuring LAN Interfaces” chapter of the *Cisco IOS Interface and Hardware Component Configuration Guide*, http://www.cisco.com/en/US/docs/ios/12_2/interface/configuration/guide/icflanin.html

For information on interface numbering, see the software configuration guide for your router.

SUMMARY STEPS

1. **enable**
2. **show ip interface brief**
3. **configure terminal**
4. **interface {fastethernet | gigabitethernet} 0/0/port**
5. **description string**
6. **ip address ip-address mask**
7. **no shutdown**
8. **end**
9. **show ip interface brief**

DETAILED STEPS

	Command or Action	Purpose
Step 1	enable Example: Router> enable	Enables privileged EXEC mode. <ul style="list-style-type: none"> • Enter your password if prompted.
Step 2	show ip interface brief Example: Router# show ip interface brief	Displays a brief status of the interfaces that are configured for IP. <ul style="list-style-type: none"> • Learn which type of Ethernet interface is on your router.
Step 3	configure terminal Example: Router# configure terminal	Enters global configuration mode.
Step 4	interface {fastethernet gigabitethernet} 0/port Example: Router(config)# interface gigabitethernet 0/0/0	Specifies the Ethernet interface and enters interface configuration mode. Note For information on interface numbering, see About Slot, Subslot (Bay), and Port Numbering, page 1-40 .
Step 5	description string Example: Router(config-if)# description GE int to 2nd floor south wing	(Optional) Adds a description to an interface configuration. <ul style="list-style-type: none"> • The description helps you remember what is attached to this interface. The description can be useful for troubleshooting.
Step 6	ip address ip-address mask Example: Router(config-if)# ip address 172.16.74.3 255.255.255.0	Sets a primary IP address for an interface.

	Command or Action	Purpose
Step 7	<code>no shutdown</code> Example: Router(config-if)# no shutdown	Enables an interface.
Step 8	<code>end</code> Example: Router(config)# end	Returns to privileged EXEC mode.
Step 9	<code>show ip interface brief</code> Example: Router# show ip interface brief	Displays a brief status of the interfaces that are configured for IP. <ul style="list-style-type: none"> Verify that the Ethernet interfaces are up and configured correctly.

Configuration Examples

Configuring the GigabitEthernet Interface: Example

```
!
interface GigabitEthernet0/0/0
  description GE int to HR group
  ip address 172.16.3.3 255.255.255.0
  duplex auto
  speed auto
  no shutdown
!
```

Sample Output for the show ip interface brief Command

```
Router#show ip interface brief
Interface                IP-Address      OK? Method Status                Protocol
GigabitEthernet0/0/0    unassigned      YES NVRAM    administratively down  down
GigabitEthernet0/0/1    unassigned      YES NVRAM    administratively down  down
GigabitEthernet0/0/2    unassigned      YES NVRAM    administratively down  down
GigabitEthernet0/0/3    unassigned      YES NVRAM    administratively down  down
GigabitEthernet0        10.0.0.1        YES manual    up                      up
```

Specifying a Default Route or Gateway of Last Resort

This section describes how to specify a default route with IP routing enabled. For alternative methods of specifying a default route, see the [Configuring a Gateway of Last Resort Using IP Commands](#) tech note.

The Cisco IOS-XE software uses the gateway (router) of last resort if it does not have a better route for a packet and if the destination is not a connected network. This section describes how to select a network as a default route (a candidate route for computing the gateway of last resort). The way in which routing protocols propagate the default route information varies for each protocol.

Configuring IP Routing and IP Protocols

For comprehensive configuration information about IP routing and IP routing protocols, see the [Configuring IP Routing Protocol-Independent Feature](#) on Cisco.com.

IP Routing

IP routing is automatically enabled in the Cisco IOS-XE software. When IP routing is configured, the system will use a configured or learned route to forward packets, including a configured default route.

**Note**

This task section does not apply when IP routing is disabled. To specify a default route when IP routing is disabled, refer to the [Configuring a Gateway of Last Resort Using IP Commands](#) tech note on Cisco.com.

Default Routes

A router might not be able to determine the routes to all other networks. To provide complete routing capability, the common practice is to use some routers as smart routers and give the remaining routers default routes to the smart router. (Smart routers have routing table information for the entire internetwork.) These default routes can be passed along dynamically, or can be configured into the individual routers.

Most dynamic interior routing protocols include a mechanism for causing a smart router to generate dynamic default information that is then passed along to other routers.

Default Network

If a router has an interface that is directly connected to the specified default network, the dynamic routing protocols running on the router will generate or source a default route. In the case of RIP, the router will advertise the pseudonetwork 0.0.0.0. In the case of IGRP, the network itself is advertised and flagged as an exterior route.

A router that is generating the default for a network also may need a default of its own. One way a router can generate its own default is to specify a static route to the network 0.0.0.0 through the appropriate device.

Gateway of Last Resort

When default information is being passed along through a dynamic routing protocol, no further configuration is required. The system periodically scans its routing table to choose the optimal default network as its default route. In the case of RIP, there is only one choice, network 0.0.0.0. In the case of IGRP, there might be several networks that can be candidates for the system default. The Cisco IOS-XE software uses both administrative distance and metric information to determine the default route (gateway of last resort). The selected default route appears in the gateway of last resort display of the **show ip route EXEC** command.

If dynamic default information is not being passed to the software, candidates for the default route are specified with the **ip default-network** global configuration command. In this usage, the **ip default-network** command takes an unconnected network as an argument. If this network appears in the routing table from any source (dynamic or static), it is flagged as a candidate default route and is a possible choice as the default route.

If the router has no interface on the default network, but does have a route to it, it considers this network as a candidate default path. The route candidates are examined and the best one is chosen, based on administrative distance and metric. The gateway to the best default path becomes the gateway of last resort.

SUMMARY STEPS

1. **enable**
2. **configure terminal**
3. **ip route** *dest-prefix mask next-hop-ip-address* [*admin-distance*] [**permanent**]
4. **ip default-network** *network-number*
or
ip route *dest-prefix mask next-hop-ip-address*
5. **end**
6. **show ip route**

DETAILED STEPS

	Command or Action	Purpose
Step 1	enable Example: Router> enable	Enables privileged EXEC mode. <ul style="list-style-type: none"> • Enter your password if prompted.
Step 2	configure terminal Example: Router# configure terminal	Enters global configuration mode.
Step 3	ip routing Example: Router(config)# ip routing	Enables IP routing.
Step 4	ip route <i>dest-prefix mask next-hop-ip-address</i> [<i>admin-distance</i>] [permanent] Example: Router(config)# ip route 192.168.24.0 255.255.255.0 172.28.99.2	Establishes a static route.

	Command or Action	Purpose
Step 5	<pre>ip default-network network-number or ip route dest-prefix mask next-hop-ip-address</pre> <p>Example: Router(config)# ip default-network 192.168.24.0</p> <p>Example: Router(config)# ip route 0.0.0.0 0.0.0.0 172.28.99.1</p>	<p>Selects a network as a candidate route for computing the gateway of last resort.</p> <p>Creates a static route to network 0.0.0.0 0.0.0.0 for computing the gateway of last resort.</p>
Step 6	<pre>end</pre> <p>Example: Router(config)# end</p>	Returns to privileged EXEC mode.
Step 7	<pre>show ip route</pre> <p>Example: Router# show ip route</p>	<p>Displays the current routing table information.</p> <ul style="list-style-type: none"> Verify that the gateway of last resort is set.

Configuration Examples

Specifying a Default Route: Example

```
!
ip route 192.168.24.0 255.255.255.0 172.28.99.2
!
ip default-network 192.168.24.0
!
```

Sample Output for the show ip route Command

```
Router# show ip route
Codes: L - local, C - connected, S - static, R - RIP, M - mobile, B - BGP
       D - EIGRP, EX - EIGRP external, O - OSPF, IA - OSPF inter area
       N1 - OSPF NSSA external type 1, N2 - OSPF NSSA external type 2
       E1 - OSPF external type 1, E2 - OSPF external type 2, i - IS-IS, su - IS-IS
       summary, L1 - IS-IS level-1, L2 - IS-IS level-2, ia - IS-IS inter area, * -
       candidate default,
       U - per-user static route, o - ODR, P - periodic downloaded static route, H - NHRP,
       l - LISP, a - application route, + - replicated route, % - next hop override

Gateway of last resort is not set
40.0.0.0/8 is variably subnetted, 2 subnets, 2 masks
C 40.0.0.0/24 is directly connected, Loopback1
L 40.0.0.1/32 is directly connected, Loopback1
Router#
```

Configuring Virtual Terminal Lines for Remote Console Access

Virtual terminal (vty) lines are used to allow remote access to the router. This section shows you how to configure the virtual terminal lines with a password, so that only authorized users can remotely access the router.

The router has five virtual terminal lines by default. However, you can create additional virtual terminal lines. See the Cisco IOS XE Dial Technologies Configuration Guide at http://www.cisco.com/en/US/docs/ios/dial/configuration/guide/2_xe/dia_2_xe_book.html.

Line passwords and password encryption is described in the Cisco IOS XE Security Configuration Guide: *Secure Connectivity* at the following URL: http://www.cisco.com/en/US/docs/ios/ios_xe/sec_secure_connectivity/configuration/guide/2_xe/sec_secure_connectivity_xe_book.html. See the *Security with Passwords, Privilege Levels, and Login Usernames for CLI Sessions on Networking Devices* section. If you want to secure the vty lines with an access list, see the *Access Control Lists: Overview and Guidelines*.

SUMMARY STEPS

1. **enable**
2. **configure terminal**
3. **line vty** *line-number* [*ending-line-number*]
4. **password** *password*
5. **login**
6. **end**
7. **show running-config**
8. From another network device, attempt to open a Telnet session to the router.

DETAILED STEPS

	Command or Action	Purpose
Step 1	enable Example: Router> enable	Enables privileged EXEC mode. <ul style="list-style-type: none"> • Enter your password if prompted.
Step 2	configure terminal Example: Router# configure terminal	Enters global configuration mode.
Step 3	line vty <i>line-number</i> [<i>ending-line-number</i>] Example: Router(config)# line vty 0 4	Starts the line configuration command collection mode for the virtual terminal lines (vty) for remote console access. <ul style="list-style-type: none"> • Make sure that you configure all vty lines on your router. <p>Note To verify the number of vty lines on your router, use the line vty ? command.</p>

	Command or Action	Purpose
Step 4	<code>password password</code> Example: Router(config-line)# <code>password guessagain</code>	Specifies a password on a line.
Step 5	<code>login</code> Example: Router(config-line)# <code>login</code>	Enables password checking at login.
Step 6	<code>end</code> Example: Router(config-line)# <code>end</code>	Returns to privileged EXEC mode.
Step 7	<code>show running-config</code> Example: Router# <code>show running-config</code>	Displays the running configuration file. <ul style="list-style-type: none"> Verify that you properly configured the virtual terminal lines for remote access.
Step 8	From another network device, attempt to open a Telnet session to the router. Example: Router# <code>172.16.74.3</code> Password:	Verifies that you can remotely access the router and that the virtual terminal line password is correctly configured.

Configuration Examples

The following example shows how to configure virtual terminal lines with a password:

```
!
line vty 0 4
  password guessagain
  login
!
```

What to Do Next

After you configure the vty lines, follow these steps:

- (Optional) To encrypt the virtual terminal line password, see the “Configuring Passwords and Privileges” chapter in the *Cisco IOS Security Configuration Guide*. Also see the *Cisco IOS Password Encryption Facts* tech note.
- (Optional) To secure the VTY lines with an access list, see the “Part 3: Traffic Filtering and Firewalls” in the *Cisco IOS Security Configuration Guide*.

Configuring the Auxiliary Line

This section describes how to enter line configuration mode for the auxiliary line. How you configure the auxiliary line depends on your particular implementation of the auxiliary (AUX) port. See the following documents for information on configuring the auxiliary line:

- *Configuring a Modem on the AUX Port for EXEC Dialin Connectivity*, tech note
http://www.cisco.com/en/US/tech/tk801/tk36/technologies_tech_note09186a0080094bbc.shtml
- *Configuring Dialout Using a Modem on the AUX Port*, sample configuration
http://www.cisco.com/en/US/tech/tk801/tk36/technologies_configuration_example09186a0080094579.shtml
- *Configuring AUX-to-AUX Port Async Backup with Dialer Watch*, sample configuration
http://www.cisco.com/en/US/tech/tk801/tk36/technologies_configuration_example09186a0080093d2b.shtml
- *Modem-Router Connection Guide*, tech note
http://www.cisco.com/en/US/tech/tk801/tk36/technologies_tech_note09186a008009428b.shtml

SUMMARY STEPS

1. **enable**
2. **configure terminal**
3. **line aux 0**
4. See the tech notes and sample configurations to configure the line for your particular implementation of the AUX port.

DETAILED STEPS

	Command or Action	Purpose
Step 1	enable Example: Router> enable	Enables privileged EXEC mode. <ul style="list-style-type: none"> • Enter your password if prompted.
Step 2	configure terminal Example: Router# configure terminal	Enters global configuration mode.
Step 3	line aux 0 Example: Router(config)# line aux 0	Starts the line configuration command collection mode for the auxiliary line.
Step 4	See the tech notes and sample configurations to configure the line for your particular implementation of the AUX port.	—

Verifying Network Connectivity

This section describes how to verify network connectivity for your router.

Prerequisites

- Complete all previous configuration tasks in this document.
- The router must be connected to a properly configured network host.

SUMMARY STEPS

1. **enable**
2. **ping** [*ip-address* | *hostname*]
3. **telnet** {*ip-address* | *hostname*}

DETAILED STEPS

	Command or Action	Purpose
Step 1	enable Example: Router> enable	Enables privileged EXEC mode. <ul style="list-style-type: none"> • Enter your password if prompted.
Step 2	ping [<i>ip-address</i> <i>hostname</i>] Example: Router# ping 172.16.74.5	Diagnoses initial network connectivity. <ul style="list-style-type: none"> • To verify connectivity, ping the next hop router or connected host for each configured interface to.
Step 3	telnet { <i>ip-address</i> <i>hostname</i> } Example: Router# telnet 10.20.30.40	Logs in to a host that supports Telnet. <ul style="list-style-type: none"> • If you want to test the vty line password, perform this step from a different network device, and use your router's IP address.

Examples

The following display shows sample output for the ping command when you ping the IP address 192.168.7.27:

```
Router# ping

Protocol [ip]:
Target IP address: 192.168.7.27
Repeat count [5]:
Datagram size [100]:
Timeout in seconds [2]:
Extended commands [n]:
Sweep range of sizes [n]:
Type escape sequence to abort.
Sending 5, 100-byte ICMP Echos to 192.168.7.27, timeout is 2 seconds:
!!!!
Success rate is 100 percent, round-trip min/avg/max = 1/2/4 ms
```

The following display shows sample output for the ping command when you ping the IP hostname donald:

```
Router# ping donald
```

```
Type escape sequence to abort.
```

```
Sending 5, 100-byte ICMP Echos to 192.168.7.27, timeout is 2 seconds:
```

```
!!!!!
```

```
Success rate is 100 percent, round-trip min/avg/max = 1/3/4 ms
```

Saving Your Router Configuration

This section describes how to avoid losing your configuration at the next system reload or power cycle by saving the running configuration to the startup configuration in NVRAM. The NVRAM provides 256KB of storage on the router.

SUMMARY STEPS

1. **enable**
2. **copy running-config startup-config**

DETAILED STEPS

	Command or Action	Purpose
Step 1	enable Example: Router> enable	Enables privileged EXEC mode. <ul style="list-style-type: none"> • Enter your password if prompted.
Step 2	copy running-config startup-config Example: Router# copy running-config startup-config	Saves the running configuration to the startup configuration.

Saving Backup Copies of Configuration and System Image

To aid file recovery and minimize downtime in case of file corruption, we recommend that you save backup copies of the startup configuration file and the Cisco IOS-XE software system image file on a server.

SUMMARY STEPS

1. `enable`
2. `copy nvram:startup-config {ftp: | rcp: | tftp:}`
3. `show bootflash:`
4. `copy {bootflash}: {ftp: | rcp: | tftp:}`

DETAILED STEPS

	Command or Action	Purpose
Step 1	<code>enable</code> Example: Router> <code>enable</code>	Enables privileged EXEC mode. <ul style="list-style-type: none"> • Enter your password if prompted.
Step 2	<code>copy nvram:startup-config {ftp: rcp: tftp:}</code> Example: Router# <code>copy nvram:startup-config ftp:</code>	Copies the startup configuration file to a server. <ul style="list-style-type: none"> • The configuration file copy can serve as a backup copy. • Enter the destination URL when prompted.
Step 3	<code>show {bootflash0 bootflash1}:</code> Example: Router# <code>show {bootflash0 bootflash1}:</code>	Displays the layout and contents of a flash memory file system. <ul style="list-style-type: none"> • Learn the name of the system image file.
Step 4	<code>copy {bootflash0 bootflash1}: {ftp: rcp: tftp:}</code> Example: Router# <code>copy {bootflash0 bootflash1}: ftp:</code>	Copies a file from flash memory to a server. <ul style="list-style-type: none"> • Copy the system image file to a server to serve as a backup copy. • Enter the filename and destination URL when prompted.

Configuration Examples

Copying the Startup Configuration to a TFTP Server: Example

The following example shows the startup configuration being copied to a TFTP server:

```
Router# copy nvram:startup-config tftp:
Remote host[]? 172.16.101.101
Name of configuration file to write [rtr2-config]? <cr>
Write file rtr2-config on host 172.16.101.101?[confirm] <cr>
![OK]
```

Copying from Flash Memory to a TFTP Server: Example

The following example shows the use of the `show {flash0|flash1}:` command in privileged EXEC to learn the name of the system image file and the use of the `copy {flash0|flash1}: tftp:` privileged EXEC command to copy the system image to a TFTP server. The router uses the default username and password.

```
Router#Directory of bootflash:
```

```

11 drwx 16384 Jun 12 2012 17:31:45 +00:00 lost+found 64897 drwx 634880 Sep 6 2012 14:33:26
+00:00 core 340705 drwx 4096 Oct 11 2012 19:28:27 +00:00 .prst_sync 81121 drwx 4096 Jun 12
2012 17:32:39 +00:00 .rollback_timer 12 -rw- 0 Jun 12 2012 17:32:50 +00:00 tracelogs.336
713857 drwx 1347584 Oct 11 2012 20:24:26 +00:00 tracelogs 162241 drwx 4096 Jun 12 2012
17:32:51 +00:00 .installer 48673 drwx 4096 Jul 2 2012 17:14:51 +00:00 vman_fdb 13 -rw-
420654048 Aug 28 2012 15:01:31 +00:00
crankshaft-universalk9.BLD_MCP_DEV_LATEST_20120826_083012.SSA.bin 14 -rw- 727035 Aug 29
2012 21:03:25 +00:00 uut2_2000_ikev1.cfg 15 -rw- 420944032 Aug 29 2012 19:40:28 +00:00
crankshaft-universalk9.BLD_MCP_DEV_LATEST_20120829_033026.SSA.bin 16 -rw- 1528 Aug 30 2012
14:24:38 +00:00 base.cfg 17 -rw- 360900 Aug 31 2012 19:10:02 +00:00 uut2_1000_ikev1.cfg 18
-rw- 421304160 Aug 31 2012 16:34:19 +00:00
crankshaft-universalk9.BLD_MCP_DEV_LATEST_20120821_193221.SSA.bin 19 -rw- 421072064 Aug 31
2012 18:31:57 +00:00 crankshaft-universalk9.BLD_MCP_DEV_LATEST_20120830_110615.SSA.bin 20
-rw- 453652 Sep 1 2012 01:48:15 +00:00 uut2_1000_ikev1_v2.cfg 21 -rw- 16452768 Sep 11 2012
20:36:20 +00:00 upgrade_stage_1_of_1.bin.2012-09-05-Delta 22 -rw- 417375456 Sep 12 2012
20:28:23 +00:00 crankshaft-universalk9.2012-09-12_00.45_cveerapa.SSA.bin 23 -rw- 360879
Oct 8 2012 19:43:36 +00:00 old-config.conf 24 -rw- 390804800 Oct 11 2012 15:34:08 +00:00
_1010t.bin 7451738112 bytes total (4525948928 bytes free)

```

```

Router#show bootflash: #- --length-- -----date/time----- path 1 4096 Oct 11 2012
20:22:19 +00:00 /bootflash/ 2 16384 Jun 12 2012 17:31:45 +00:00 /bootflash/lost+found 3
634880 Sep 06 2012 14:33:26 +00:00 /bootflash/core 4 1028176 Sep 06 2012 14:31:17 +00:00
/bootflash/core/UUT2_RP_0_iomd_17360.core.gz 5 1023738 Sep 06 2012 14:31:24 +00:00
/bootflash/core/UUT2_RP_0_iomd_23385.core.gz 6 1023942 Sep 06 2012 14:31:30 +00:00
/bootflash/core/UUT2_RP_0_iomd_24973.core.gz 7 1023757 Sep 06 2012 14:31:37 +00:00
/bootflash/core/UUT2_RP_0_iomd_26241.core.gz 8 1023726 Sep 06 2012 14:31:43 +00:00
/bootflash/core/UUT2_RP_0_iomd_27507.core.gz 9 1023979 Sep 06 2012 14:31:50 +00:00
/bootflash/core/UUT2_RP_0_iomd_28774.core.gz 10 1023680 Sep 06 2012 14:31:56 +00:00
/bootflash/core/UUT2_RP_0_iomd_30045.core.gz 11 1023950 Sep 06 2012 14:32:02 +00:00
/bootflash/core/UUT2_RP_0_iomd_31332.core.gz 12 1023722 Sep 06 2012 14:32:09 +00:00
/bootflash/core/UUT2_RP_0_iomd_5528.core.gz 13 1023852 Sep 06 2012 14:32:15 +00:00
/bootflash/core/UUT2_RP_0_iomd_7950.core.gz 14 1023916 Sep 06 2012 14:32:22 +00:00
/bootflash/core/UUT2_RP_0_iomd_9217.core.gz 15 1023875 Sep 06 2012 14:32:28 +00:00
/bootflash/core/UUT2_RP_0_iomd_10484.core.gz 16 1023907 Sep 06 2012 14:32:35 +00:00
/bootflash/core/UUT2_RP_0_iomd_11766.core.gz 17 1023707 Sep 06 2012 14:32:41 +00:00
/bootflash/core/UUT2_RP_0_iomd_13052.core.gz 18 1023963 Sep 06 2012 14:32:48 +00:00
/bootflash/core/UUT2_RP_0_iomd_14351.core.gz 19 1023915 Sep 06 2012 14:32:54 +00:00
/bootflash/core/UUT2_RP_0_iomd_15644.core.gz 20 1023866 Sep 06 2012 14:33:00 +00:00
/bootflash/core/UUT2_RP_0_iomd_17171.core.gz 21 1023518 Sep 06 2012 14:33:07 +00:00
/bootflash/core/UUT2_RP_0_iomd_18454.core.gz 22 1023938 Sep 06 2012 14:33:13 +00:00
/bootflash/core/UUT2_RP_0_iomd_19741.core.gz 23 1024017 Sep 06 2012 14:33:20 +00:00
/bootflash/core/UUT2_RP_0_iomd_21039.core.gz 24 1023701 Sep 06 2012 14:33:26 +00:00
/bootflash/core/UUT2_RP_0_iomd_22323.core.gz 25 4096 Oct 11 2012 19:28:27 +00:00
/bootflash/.prst_sync 26 4096 Jun 12 2012 17:32:39 +00:00 /bootflash/.rollback_timer 27 0
Jun 12 2012 17:32:50 +00:00 /bootflash/tracelogs.336 28 1347584 Oct 11 2012 20:24:26
+00:00 /bootflash/tracelogs 29 392 Oct 11 2012 20:22:19 +00:00
/bootflash/tracelogs/inst_cleanup_R0-0.log.gz 30 308 Oct 11 2012 18:39:43 +00:00
/bootflash/tracelogs/inst_cleanup_R0-0.log.0000.20121011183943.gz 31 308 Oct 11 2012
18:49:44 +00:00 /bootflash/tracelogs/inst_cleanup_R0-0.log.0000.20121011184944.gz 32 42853
Oct 04 2012 07:35:39 +00:00 /bootflash/tracelogs/hman_R0-0.log.0498.20121004073539.gz 33
307 Oct 11 2012 18:59:45 +00:00
/bootflash/tracelogs/inst_cleanup_R0-0.log.0000.20121011185945.gz 34 308 Oct 11 2012
19:19:47 +00:00 /bootflash/tracelogs/inst_cleanup_R0-0.log.0000.20121011191947.gz 35 307
Oct 11 2012 19:37:14 +00:00
/bootflash/tracelogs/inst_cleanup_R0-0.log.0000.20121011193714.gz 36 308 Oct 11 2012
19:47:15 +00:00 /bootflash/tracelogs/inst_cleanup_R0-0.log.0000.20121011194715.gz 37 308
Oct 11 2012 19:57:16 +00:00
/bootflash/tracelogs/inst_cleanup_R0-0.log.0000.20121011195716.gz 38 308 Oct 11 2012
20:07:17 +00:00 /bootflash/tracelogs/inst_cleanup_R0-0.log.0000.20121011200717.gz 39 307
Oct 11 2012 20:12:18 +00:00
/bootflash/tracelogs/inst_cleanup_R0-0.log.0000.20121011201218.gz 40 306 Oct 11 2012
20:17:18 +00:00 /bootflash/tracelogs/inst_cleanup_R0-0.log.0000.20121011201718.gz 41 44220
Oct 10 2012 11:47:42 +00:00 /bootflash/tracelogs/hman_R0-0.log.32016.20121010114742.gz 42
64241 Oct 09 2012 20:47:59 +00:00

```

```

/bootflash/tracelogs/fman-fp_F0-0.log.12268.20121009204757.gz 43 177 Oct 11 2012 19:27:03
+00:00 /bootflash/tracelogs/inst_compmatrix_R0-0.log.gz 44 307 Oct 11 2012 18:24:41 +00:00
/bootflash/tracelogs/inst_cleanup_R0-0.log.0000.20121011182441.gz 45 309 Oct 11 2012
18:29:42 +00:00 /bootflash/tracelogs/inst_cleanup_R0-0.log.0000.20121011182942.gz 46 43748
Oct 06 2012 13:49:19 +00:00 /bootflash/tracelogs/hman_R0-0.log.0498.20121006134919.gz 47
309 Oct 11 2012 18:44:43 +00:00
/bootflash/tracelogs/inst_cleanup_R0-0.log.0000.20121011184443.gz 48 309 Oct 11 2012
19:04:46 +00:00 /bootflash/tracelogs/inst_cleanup_R0-0.log.0000.20121011190446.gz 49 2729
Oct 09 2012 21:21:49 +00:00 /bootflash/tracelogs/IOSRP_R0-0.log.20011.20121009212149 50
116 Oct 08 2012 21:06:44 +00:00
/bootflash/tracelogs/binos_log_R0-0.log.20013.20121008210644

```



Note To avoid losing work you have completed, be sure to save your configuration occasionally as you proceed. Use the **copy running-config startup-config** command to save the configuration to NVRAM.

Verifying the Initial Configuration

Enter the following commands in the Cisco IOS-XE to verify the initial configuration on the router:

- **show version**—Displays the system hardware version; the installed software version; the names and sources of configuration files; the boot images; and the amount of installed DRAM, NVRAM, and flash memory.
- **show diag**—Lists and displays diagnostic information about the installed controllers, interface processors, and port adapters.
- **show interfaces**— Shows interfaces are operating correctly and that the interfaces and line protocol are in the correct state—up or down
- **show ip interface brief**— Displays a summary status of the interfaces configured for IP protocol.
- **show configuration**— Verify that you have configured the correct hostname and password.
- **show platform**— Displays the software/rommon version, and so on.

When you have completed and verified the initial configuration, the specific features and functions are ready to be configured. See the [Software Configuration Guide for the Cisco 4400 and Cisco 4300 Series ISRs](#).



ROM Monitor Overview and Basic Procedures

This chapter provides an overview of ROM Monitor concepts and operations.

This chapter includes the following main topics:

- [ROM Monitor Overview, page 5-1](#)
- [Entering ROM Monitor Mode, page 5-2](#)
- [Displaying the Configuration Register Setting, page 5-6](#)
- [Environment Variable Settings, page 5-6](#)
- [Exiting ROM Monitor Mode, page 5-8](#)

ROM Monitor Overview

The *ROM Monitor* is a bootstrap program that initializes the hardware and boots the Cisco IOS XE software when you power on or reload a router. When you connect a terminal to the router that is in ROM Monitor mode, the ROM Monitor command-line interface (CLI) prompt is displayed.

During normal operation, users do not see the ROM Monitor prompt or use ROM Monitor mode. ROM Monitor mode is used only in special circumstances, such as reinstalling the entire software set, resetting the router password, or specifying a configuration file to use at startup.

The *ROM Monitor software* is known by many names. It is sometimes called *ROMMON* because of the CLI prompt in ROM Monitor mode. The ROM Monitor software is also called the *boot software*, *boot image*, or *boot helper*. Although it is distributed with routers that use the Cisco IOS XE software, ROM Monitor is a separate program from the Cisco IOS XE software. During normal startup, the ROM Monitor initializes the router, and then control passes to the Cisco IOS XE software. After the Cisco IOS XE software takes over, ROM Monitor is no longer in use.

Environmental Variables and the Configuration Register

Two primary connections exist between ROM Monitor and the Cisco IOS XE software: the ROM Monitor environment variables and the configuration register.

The ROM Monitor environment variables define the location of the Cisco IOS XE software and describe how to load it. After ROM Monitor has initialized the router, it uses the environment variables to locate and load the Cisco IOS XE software.

The *configuration register* is a software setting that controls how a card starts up. One of the primary uses of the configuration register is to control whether the router starts in ROM Monitor mode or Administration EXEC mode. The configuration register is set in either ROM Monitor mode or

Administration EXEC mode as needed. Typically, you set the configuration register using the Cisco IOS XE software prompt when you need to use ROM Monitor mode. When the maintenance in ROM Monitor mode is complete, you change the configuration register so the router reboots with the Cisco IOS XE software.

Accessing ROM Monitor Mode with a Terminal Connection

When the router is in ROM Monitor mode, you can access the ROM Monitor software only from a terminal connected directly to the console port of the card. Because the Cisco IOS XE software (EXEC mode) is not operating, the nonmanagement interfaces are not accessible. Basically, all Cisco IOS XE software resources are unavailable. The hardware is there, but no configuration exists to make use of the hardware.

Network Management Access and ROM Monitor Mode

Some people get confused when they start to use ROM Monitor mode. It is important to remember that ROM Monitor mode is a router mode, not a mode within the Cisco IOS XE software. It is best to remember that ROM Monitor software and the Cisco IOS XE software are two separate programs that run on the same router. At any given time, the router is running one of these programs, but it never runs both at the same time.

One area that can be confusing when using ROM Monitor and the Cisco IOS XE software is the area that defines the IP configuration for the Management Ethernet interface. Most router users get comfortable with configuring the Management Ethernet interface in the Cisco IOS XE software. When the router is in ROM Monitor mode, however, the router is not running the Cisco IOS XE software, so that Management Ethernet interface configuration is not available.

When you want to access other devices, such as a TFTP server, while in ROM Monitor mode on the router, you must configure the ROM Monitor variables with IP access information.

Entering ROM Monitor Mode

The following sections describe how to enter the ROMMON mode, and contains the following sections:

- [Checking the Current ROMmon Version, page 5-2](#)
- [Commonly Used ROM Monitor Commands, page 5-4](#)
- [Displaying the Available ROM Monitor Commands, page 5-5](#)
- [Changing the ROM Monitor Prompt, page 5-5](#)

Checking the Current ROMmon Version

To display the version of ROMmon running on a router, use the **show rom-monitor** command or the **show platform** command.

```
Router# show rom-monitor r0
```

```
Router#show rom-monitor r0
```

```
System Bootstrap, Version 15.4(3r)S, RELEASE SOFTWARE (fc1)
Copyright (c) 1994-2014 by cisco Systems, Inc.
```

```
.
```

```
Router#show platform
Chassis type: ISR4451/K9
```

Slot	Type	State	Insert time (ago)
0	ISR4451-X/K9	ok	00:03:25
0/0	ISR4451-X-4x1GE	ok	00:02:46
1	ISR4451-X/K9	ok	00:03:25
2	ISR4451-X/K9	ok	00:03:25
R0	ISR4451-X/K9	ok, active	00:03:25
F0	ISR4451-X/K9	ok, active	00:03:25
P0	PWR-4450-10	ok	00:03:10
P1	Unknown	ps, fail	never
P2	ACS-4450-FANASSY	ok	00:03:10

Slot	CPLD Version	Firmware Version
0	14061635	15.4(3r)S
1	14061635	15.4(3r)S
2	14061635	15.4(3r)S
R0	14061635	15.4(3r)S
F0	14061635	15.4(3r)S

```
Router#show rom-monitor r0
```

```
System Bootstrap, Version 15.4(3r)S1, RELEASE SOFTWARE (fc1)
Copyright (c) 1994-2014 by cisco Systems, Inc.
```

```
Router#show platform
Chassis type: ISR4351/K9
```

Slot	Type	State	Insert time (ago)
0	ISR4351/K9	ok	02:16:41
0/0	ISR4351-3x1GE	ok	02:15:47
1	ISR4351/K9	ok	02:16:41
2	ISR4351/K9	ok	02:16:41
R0	ISR4351/K9	ok, active	02:16:41
F0	ISR4351/K9	ok, active	02:16:41
P0	PWR-4450-AC	ok	never
P2	ACS-4450-FANASSY	ok	never

Slot	CPLD Version	Firmware Version
0	14080523	15.4(3r)S1
1	14080523	15.4(3r)S1
2	14080523	15.4(3r)S1
R0	14080523	15.4(3r)S1
F0	14080523	15.4(3r)S1

```
Router# show rom
Router# show rom?
rom-monitor romvar
```

```

Router# show romvar
ROMMON variables:
  PS1 = rommon ! >
  TFTP_FILE = /noash/overlord_627.bin
  DEFAULT_GATEWAY = 50.0.0.1
  TFTP_SERVER = 172.18.40.12
  IP_SUBNET_MASK = 255.255.255.0
  MCP_STARTUP_TRACEFLAGS = 00000000:00000000
  RET_2_RTS =
  ? = 0
  LICENSE_BOOT_LEVEL = adventerprise,all:esg;
  IP_ADDRESS = 172.18.40.56
  BSI = 0
  RET_2_RCALTS =
  RANDOM_NUM = 1707176976
Router# reload

```

```

rommon 1 > set
PS1=rommon ! >
SR_INIT_SHELL=aux_do_system_shell
TFTP_FILE=/noash/overlord_627.bin
DEFAULT_GATEWAY=50.0.0.1
TFTP_SERVER=172.18.40.12
IP_SUBNET_MASK=255.255.255.0
MCP_STARTUP_TRACEFLAGS=00000000:00000000
RET_2_RTS=
?=0
LICENSE_BOOT_LEVEL=adventerprise,all:esg;
IP_ADDRESS=172.18.40.56
BSI=0
RANDOM_NUM=1707176976
RET_2_RCALTS=1350127173

```

Commonly Used ROM Monitor Commands

Table 5-1 summarizes the commands commonly used in ROM Monitor. For specific instructions on using these commands, refer to the relevant procedure in this document.

Table 5-1 Commonly Used ROM Monitor Commands

ROMMON Command	Description
boot image	Manually boots a Cisco IOS XE software image.
boot image -o config-file-path	Manually boots the Cisco IOS XE software with a temporary alternative administration configuration file.
confreg	Changes the config-register setting.
dev	Displays the available local storage devices.
dir	Displays the files on a storage device.
reset	Resets the node.
set	Displays the currently set ROM Monitor environmental settings.
sync	Saves the new ROM Monitor environmental settings.
unset	Removes an environmental variable setting.

Displaying the Available ROM Monitor Commands

Table 5-2 describes the available **help** commands for ROM Monitor mode.

Table 5-2 Help Commands in ROMMON

Command	Description
help or ?	Displays a summary of all available ROM Monitor commands.
-?	Displays information about command syntax.



Note

Commands are case-sensitive. You can halt any command by pressing **Ctrl-C**.

Examples

The following example shows what appears when you enter the **?** command on a router:

```
rommon 1 > ?
alias                set and display aliases command
boot                 boot up an external process
break                set/show/clear the breakpoint
confreg              configuration register utility
context              display the context of a loaded image
cookie               display contents of cookie PROM in hex
dev                  list the device table
dir                  list files in file system
dis                  display instruction stream
frame                print out a selected stack frame
help                 monitor builtin command help
history              monitor command history
meminfo              main memory information
repeat               repeat a monitor command
reset                system reset
set                  display the monitor variables
showmon              display currently selected ROM monitor
stack                produce a stack trace
sync                 write monitor environment to NVRAM
sysret               print out info from last system return
tsec                 print out info from the ethernet driver
unalias              unset an alias
unset                unset a monitor variable
```

Changing the ROM Monitor Prompt

You can change the prompt in ROM Monitor mode by using the **PS1=** command as shown in the following example:

```
rommon 8 > PS1="ISR4400 rommon ! > "
ISR4400 rommon 9 >
```

Changing the prompt is useful if you are working with multiple routers in ROM Monitor at the same time. This example specifies that the prompt should be “ISR4400 rommon ”, followed by the line number, and then followed by “ > “ by the line number.

Displaying the Configuration Register Setting

To display the current configuration register setting, enter the **confreg** command without parameters as follows:

```
rommon > confreg

          Configuration Summary
(Virtual Configuration Register: )
enabled are:
console baud: 9600
boot: the ROM Monitor

do you wish to change the configuration? y/n [n]:
```

The configuration register setting is labeled *Virtual Configuration Register*. Enter the **no** command to avoid changing the configuration register setting.

Environment Variable Settings

The ROM Monitor environment variables define the attributes of the ROM Monitor. Environmental variables are entered like commands and are always followed by the equal sign (=). Environment variable settings are entered in capital letters, followed by a definition. For example:

```
IP_ADDRESS=10.0.0.2
```

Under normal operating conditions, you do not need to modify these variables. They are cleared or set only when you need to make changes to the way ROM Monitor operates.

This section includes the following topics:

- [Frequently Used Environmental Variables, page 5-7](#)
- [Displaying Environment Variable Settings, page 5-7](#)
- [Entering Environment Variable Settings, page 5-8](#)
- [Saving Environment Variable Settings, page 5-8](#)

Frequently Used Environmental Variables

Table 5-3 shows the main ROM Monitor environmental variables. For instructions on how to use these variables, see the relevant instructions in this document.

Table 5-3 Frequently Used ROM Monitor Environmental Variables

Environmental variable	Description
IP_ADDRESS = <i>ip_address</i>	Sets the IP address for the Management Ethernet interface.
IP_SUBNET_MASK = <i>ip_address</i>	Sets the subnet mask for the Management Ethernet interface.
DEFAULT_GATEWAY = <i>ip_address</i>	Sets the default gateway that serves.
TFTP_SERVER = <i>ip_address</i>	Sets the IP address of the TFTP server where a bootable software image is located.
TFTP_FILE = <i>path/file</i>	Sets the directory and filename of a bootable software image.
BOOT = <i>path/file</i>	Identifies the boot software for a node. This variable is usually set automatically when the router boots.

Displaying Environment Variable Settings

To display the current environment variable settings, enter the **set** command :

```
rommon 1 > showmon
Current image running (0/1): Boot ROM0

System Bootstrap, Version 12.2(20120829:165313)
DEVELOPMENT SOFTWARE
Copyright (c) 1994-2012 by cisco Systems, Inc.

Compiled Wed 08/29/2012 12:53:32.67

CPLD Version      : 35 (MM/DD/YY): 09/03/12 (2.3)
FPGA Version      : 0x82020300 (2.3.0)
FPGA Active       : read-only image
Board Version     : 2 (P1C)
PCH Version       : 10 (B0)
DP CPU Version    : 00 (1.0)
FPGA-ENV Version: 0105
HDD Status        : 0A30
MEFW Version      : 6.0.50.1244
System Straps     : 00000F00 BE036FF1 B2EB6E8F
Hardware Anchor   : F01001R06.0116f365a2012-07-17
Certificate       : 946944F17906C95E
Microloader       : MA0001R04.013eb9f7f2012-06-22
Module 0/1        : Absent
Module 0/2        : Absent
Module 0/3        : Absent
Module 0/4        : Absent
Module 1/0        : Absent
Module 2/0        : Absent
PCH Enum Errs    : 0
```

Entering Environment Variable Settings

Environment variable settings are entered in capital letters, followed by a definition. The following example shows the environmental variables used to configure the control Ethernet port on a router:

```
rommon > IP_ADDRESS=1.1.1.1
rommon > IP_SUBNET_MASK=255.255.254.0
rommon > DEFAULT_GATEWAY=1.1.0.1
```

Saving Environment Variable Settings

To save the current environment variable settings, enter the **sync** command:

```
rommon > sync
```



Note

Environmental values that are not saved with the **sync** command are discarded whenever the system is reset or booted.

Exiting ROM Monitor Mode

To exit ROM Monitor mode, you must change the configuration register and reset the router.

SUMMARY STEPS

1. **confreg**
2. Respond to each prompt as instructed.
3. **reset**

DETAILED STEPS

	Command or Action	Purpose
Step 1	confreg Example: rommon 1> confreg	Initiates the configuration register configuration prompts.
Step 2	Respond to each prompt as instructed.	See the example that follows this procedure for more information.
Step 3	reset Example: rommon 2> reset	Resets and initializes the router.

Configuration Example

```
rommon 3 > confreg

                Configuration Summary
(Virtual Configuration Register: 0x0)
enabled are:
[ 0 ] break/abort has effect
[ 1 ] console baud: 9600
boot: ..... the ROM Monitor

do you wish to change the configuration? y/n [n]: y
enable "diagnostic mode"? y/n [n]:
enable "use net in IP bcast address"? y/n [n]:
enable "load rom after netboot fails"? y/n [n]:
enable "use all zero broadcast"? y/n [n]:
disable "break/abort has effect"? y/n [n]:
enable "ignore system config info"? y/n [n]:
change console baud rate? y/n [n]:
change the boot characteristics? y/n [n]:

                Configuration Summary
(Virtual Configuration Register: 0x0)
enabled are:
[ 0 ] break/abort has effect
[ 1 ] console baud: 9600
boot: ..... the ROM Monitor

do you wish to change the configuration? y/n [n]:
```

Upgrading the ROMmon for a Router

Use this procedure to upgrade the ROMmon on a router:

-
- Step 1** (Optional) Run the **show platform** command or the **show rom-monitor slot** command on the router to see the current release numbers of ROMmon on the hardware. See the [“Checking the Current ROMmon Version” section on page 5-2](#) for information about interpreting the output of the command that you run.
 - Step 2** If the ROMmon image has not been copied onto the router, copy the PKG file that is made available as part of this ROMmon release onto the bootflash: or usb[0-1]: file system using the copy source-location destination-location command. For example, if you are upgrading to Release 15.2(1r)S, copy the isr4400-rommon-154-3r.S.pkg file.
 - Step 3** Run the **dir file-system** command to verify that the ROMmon file is copied into the specified directory.
 - Step 4** Run the **upgrade rom-monitor filename location all** command to begin the ROMmon image upgrade, where *location* is the path to the ROMmon file.



Caution

Do not remove hardware, turn off power, or interrupt the router in any way during the ROMmon upgrade. Although the router should be able to recover from most interruptions during the ROMmon upgrade, certain scenarios may cause unpredictable problems.

- Step 5** Messages pertaining to the upgrade are displayed on the console. After the display of these messages stops and the router prompt is available, run the **reload** command to reload the router.
- Step 6** If autoboot has not been enabled by using the **config-register 0x2102** command, run the **boot filesystem:/file-location** command at the ROMmon prompt to boot the Cisco IOS XE image, where *filesystem:/file-location* is the path to the consolidated package file. The ROMmon upgrade is not permanent for any piece of hardware until the Cisco IOS XE image is booted.
- Step 7** Run the **enable** command at the user prompt to enter the privileged EXEC mode after the boot is complete.
- Step 8** Run the **show platform** command or the **show rom-monitor slot** command to verify whether the ROMmon has been upgraded.
-



Installing and Upgrading Internal Modules and FRUs

This document describes how to install and upgrade internal modules and field replaceable units (FRUs) in the Cisco 4000 Series Integrated Services Routers (ISRs). The install and upgrade information is contained in these sections:

Internal and External Modules

- [Safety Warnings, page 6-2](#)
- [Modules Supported, page 6-4](#)
- [Accessing Internal Modules, page 6-5](#)
- [Locating Internal and External Slots for Modules on the Cisco 4451 ISR, page 6-6](#)
- [Locating Internal and External Slots for Modules on the Cisco 4351 ISR, page 6-8](#)
- [Locating Internal and External Slots for Modules on the Cisco 4331 ISR, page 6-9](#)
- [Overview of the NIM-HDD Card, page 6-19](#)
- [Removing and Replacing the Cisco NIM-SSD or NIM-HDD, page 6-21](#)
- [Installing and Removing DDR DIMMs, page 6-24](#)
- [Installing and Removing NIMs and SM-Xs, page 6-29](#)
- [Installing and Removing the PVDM4, page 6-31](#)
- [Removing and Replacing the USB Flash Token Memory Stick, page 6-38](#)
- [Removing and Replacing the Cisco 4000 Series ISRs Power Supplies, page 6-39](#)
- [Removing and Installing a CompactFlash Memory Card, page 6-58](#)
- [Removing and Installing a Flash Memory Card, page 6-60](#)
- [Installing and Removing an SSD mSATA Storage Device, page 6-63](#)
- [Removing, Replacing, and Installing an Internal PoE Daughter Card, page 6-70](#)

FRUs

- [Replacing a Fan Tray, page 6-54](#)
- [Replacing the Fan Tray on a Cisco 4331 ISR, page 6-55](#)
- [Removing and Installing a CompactFlash Memory Card, page 6-58](#)
- [Installing and Removing SFP Modules, page 6-66](#)

- [Removing and Replacing the Cisco 4000 Series ISRs Power Supplies](#), page 6-39
-

**Caution**

Read the [Safety Warnings](#) section and disconnect the power supply before you perform any module replacement.

See the “[Modules Supported](#)” section on page 6-4 for instructions on how to install and replace internal components.

Safety Warnings

**Warning**

Read the installation instructions before connecting the system to the power source. Statement 1004

**Warning**

Only trained and qualified personnel should be allowed to install, replace, or service this equipment. Statement 1030

**Warning**

This equipment must be installed and maintained by service personnel as defined by AS/NZS 3260. Incorrectly connecting this equipment to a general-purpose outlet could be hazardous. The telecommunications lines must be disconnected 1) before unplugging the main power connector or 2) while the housing is open, or both. Statement 1043

**Warning**

Before working on a system that has an on/off switch, turn OFF the power and unplug the power cord. Statement 1

**Warning**

This unit might have more than one power supply connection. All connections must be removed to de-energize the unit. Statement 1028

**Warning**

This equipment must be grounded. Never defeat the ground conductor or operate the equipment in the absence of a suitably installed ground conductor. Contact the appropriate electrical inspection authority or an electrician if you are uncertain that suitable grounding is available. Statement 1024

**Warning**

Hazardous network voltages are present in WAN ports regardless of whether power to the unit is OFF or ON. To avoid electric shock, use caution when working near WAN ports. When detaching cables, detach the end away from the unit first. Statement 1026

**Warning**

Before opening the unit, disconnect the telephone-network cables to avoid contact with telephone-network voltages. Statement 1041

**Warning**

Before working on equipment that is connected to power lines, remove jewelry (including rings, necklaces, and watches). Metal objects will heat up when connected to power and ground and can cause serious burns or weld the metal object to the terminals. Statement 43

**Warning**

Do not use this product near water; for example, near a bath tub, wash bowl, kitchen sink or laundry tub, in a wet basement, or near a swimming pool. Statement 1035

**Warning**

Never install telephone jacks in wet locations unless the jack is specifically designed for wet locations. Statement 1036

**Warning**

Never touch uninsulated telephone wires or terminals unless the telephone line has been disconnected at the network interface. Statement 1037

**Warning**

Avoid using a telephone (other than a cordless type) during an electrical storm. There may be a remote risk of electric shock from lightning. Statement 1038

**Warning**

To report a gas leak, do not use a telephone in the vicinity of the leak. Statement 1039

**Warning**

There is the danger of explosion if the battery is replaced incorrectly. Replace the battery only with the same or equivalent type recommended by the manufacturer. Dispose of used batteries according to the manufacturer's instructions. Statement 1015

**Warning**

Blank faceplates and cover panels serve three important functions: they prevent exposure to hazardous voltages and currents inside the chassis; they contain electromagnetic interference (EMI) that might disrupt other equipment; and they direct the flow of cooling air through the chassis. Do not operate the system unless all cards, faceplates, front covers, and rear covers are in place. Statement 1029

**Warning**

For connections outside the building where the equipment is installed, the following ports must be connected through an approved network termination unit with integral circuit protection.

T1 SFP Statement 1044

Modules Supported

The router supports the modules listed in [Table 6-1](#).

Table 6-1 *Modules Supported on the Cisco 4000 Series ISRs*

Module Name	Type of Module	Cisco ISR4451-X	Cisco ISR4431	Cisco ISR4451	Cisco ISR4331	Cisco ISR4321	Cisco IOS XE Release
Cisco Fourth-Generation T1/E1 Voice and WAN NIM	Network Interface Module	Yes	Yes	Yes	Yes	Yes	3.9S and higher
Cisco SSD Carrier Card NIM	Network Interface Module	Yes	Yes	Yes	Yes	Yes	3.9S and higher
Cisco HDD Carrier Card NIM	Network Interface Module	Yes	Yes	Yes	Yes	Yes	3.12S and higher
Cisco Multi-protocol Synchronous Serial NIM	Network Interface Module	Yes	Yes	Yes	Yes	Yes	3.12S and higher
Cisco SM-X-1T3/E3	Enhanced Service Module	Yes	No	Yes	Yes	No	3.9S and higher
Cisco UCS-E140D-M1/K9, Cisco UCS-E160D-M2/K9 and Cisco UCS-E180D-M2/K9	Service Module	Yes	No	Yes	Yes (Single-wide)	No	3.9S and higher
Cisco SM-X Layer 2/3 EtherSwitch Service Module	Enhanced Service Module	Yes	No	Yes	Yes (Single-wide)	No	3.11S and higher
Cisco 6-port GE SFP Service Module	Enhanced Service Module	Yes	No	Yes	Yes	No	3.11S and higher
Cisco Fourth-Generation Voice and Fax Network Interface Module	Network Interface Module	Yes	Yes	Yes	Yes	Yes	3.13S or higher
Cisco 4-port GE SFP and 1-port 10 GE SFP Service Module (SM-X-4x1GE-1x10GE)	Enhanced Service Module	Yes	No	Yes	Yes	No	3.13S or higher

Accessing Internal Modules

To access the internal modules on the router, you must first remove the chassis cover. See the [Replacing the Chassis Cover, page 6-5](#) for instructions on how to remove and later replace the chassis cover on the routers.

Replacing the Chassis Cover

The Cisco 4000 Series ISRs have a removable cover.

**Caution**

Do not run the router with the cover off. Doing so can cause the router to overheat very quickly.

**Warning**

Before opening the unit, disconnect the telephone-network cables to avoid contact with telephone-network voltages. Statement 1041

**Note**

Use a number-2 Phillips screwdriver to perform the following tasks.

Removing the Cover

To remove the cover, perform the following steps.

- Step 1** Read the [“Safety Warnings” section on page 6-2](#) and disconnect the power supply before you perform any module replacement.
- Step 2** Confirm the router is turned off and disconnected from the power supply or power supplies. If a redundant power is used, disconnect from the redundant power supply.
- Step 3** Place the chassis on a flat surface.
- Step 4** Remove the three cover screws at the back of the router cover. See [Figure 6-1](#).
- Step 5** Lift the cover from the back edge to a 45-degree angle.
- Step 6** Pull the cover towards you to disengage the slots along the front (bezel) edge of the chassis. See [Figure 6-1](#).

Replacing the Cover

To replace the cover, perform the following steps.

- Step 1** Read the [Safety Warnings, page 6-2](#) and disconnect the power supply before you perform any module replacement.
- Step 2** Confirm the router is turned off and disconnected from the power supply or power supplies. If a redundant power is used disconnect from the redundant power supply.
- Step 3** Place the chassis on a flat surface.

- Step 4** Hold the cover at a 45-degree angle and insert the cover tabs into the slots along the front (bezel) edge of the chassis. See [Figure 6-1](#).
- Step 5** Center the cover over the chassis and lower it onto the chassis.
- Step 6** Install the three cover screws.

Figure 6-1 Installing the Cover on the Router (Shown Cisco ISR 4451-X)

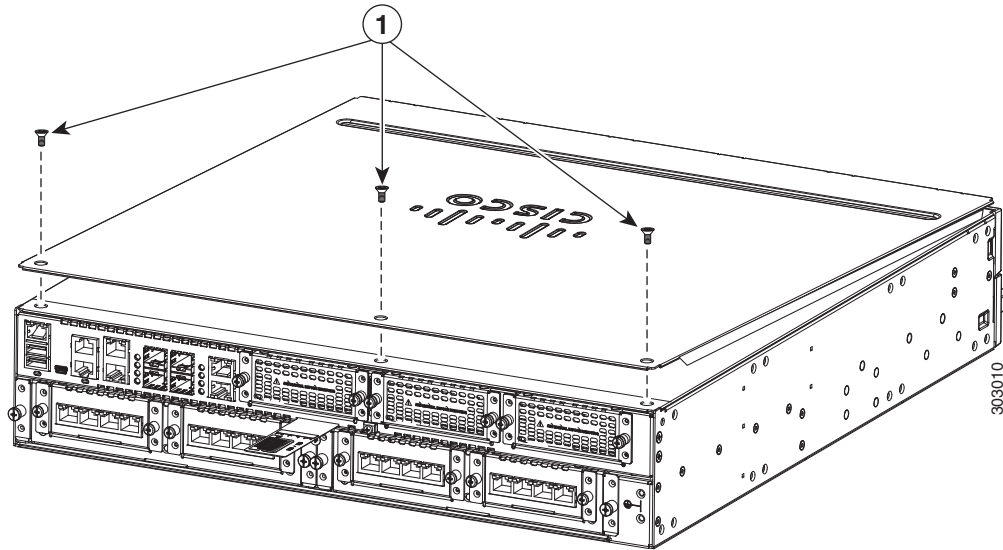

1	Cover screws (3)
----------	------------------

Locating Internal and External Slots for Modules on the Cisco 4451 ISR

[Figure 6-2](#) shows the locations of internal modules on the router motherboard. Internal modules include DIMMs, PVDM4, and PoE daughter card on the Cisco ISR 4451-X. [Figure 6-25](#) shows the location of the available slots including the Integrated Services Card (ISC) slot.

Figure 6-2 Module Locations in the Cisco ISR 4451-Xs

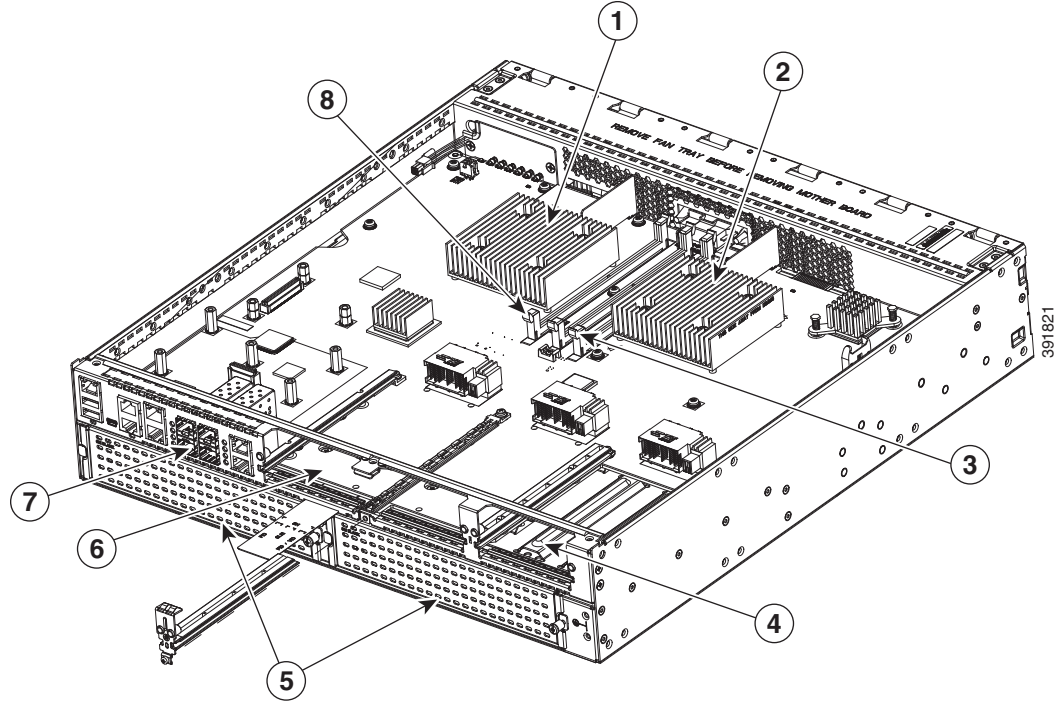

1	Forwarding plane processor	2	Control plane processor
3	Control plane processor DIMM	4	NIM 3 (single-wide) slot
5	Enhanced Service Module (SM-X) slots	6	NIM slot 1 and 2 (shown with slot divider removed)
7	SFP GE ports	8	Forwarding plane processor DIMM

Locating Internal and External Slots for Modules on the Cisco 4351 ISR

Figure 1-13 shows an internal view of the Cisco ISR 4351 chassis with all the parts and module location.

Figure 6-3 *Module Locations in the Cisco ISR 4351 chassis*

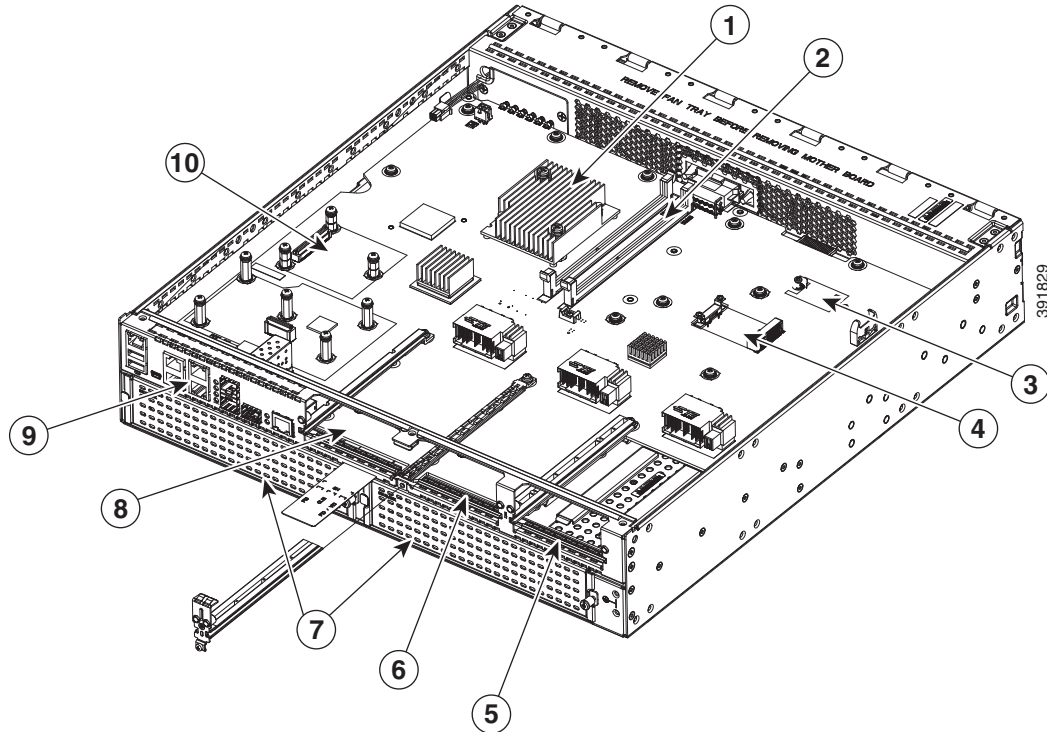

1	CPU	2	DIMMs
3	Flash memory card connector	4	SSD mSATA connector
5	NIM slot 3	6	NIM slot 2
7	SM-X slots	8	NIM slot 1
9	RJ-45 GE ports	10	ISC slot

Locating Internal and External Slots for Modules on the Cisco 4331 ISR

Figure 6-4 shows the locations of internal modules on the Cisco 4331 ISR router motherboard. Internal modules include DIMMs, PVDM4, and PoE daughter card on the Cisco 4331 ISR. Figure 6-26 shows the location of the available slots including the Integrated Services Card (ISC) slot.

Figure 6-4 shows an internal view of the Cisco 4331 ISR chassis with all the parts and module location.

Figure 6-4 Module Locations in the Cisco 4331 ISR chassis

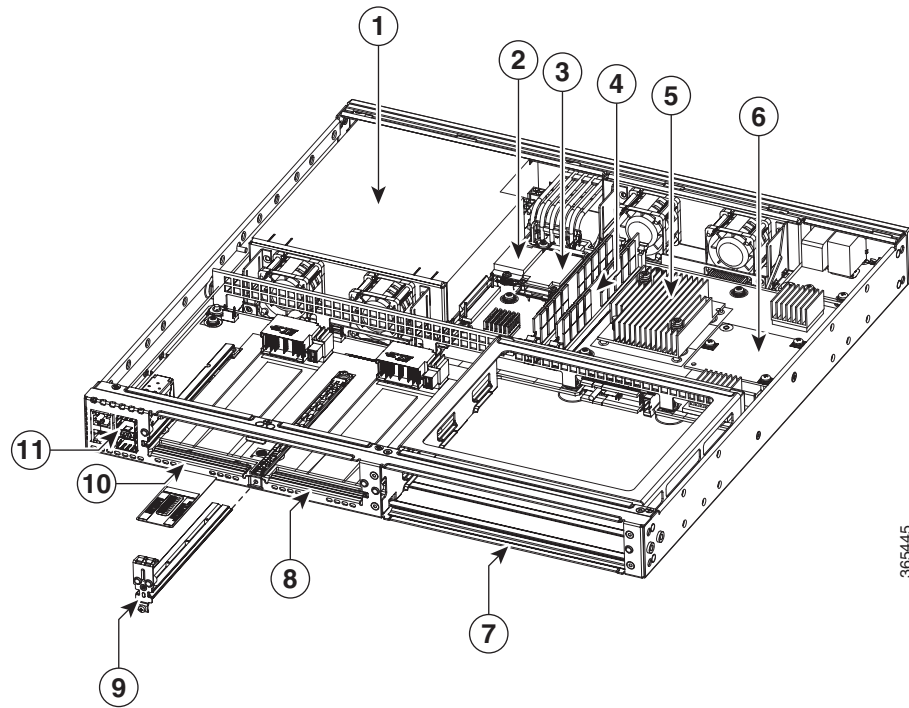

1	CPU	2	DIMMs
3	Flash memory card connector	4	SSD mSATA connector
5	ISC /PVDM-4 slot	6	Power Supply
7	SM-X Slot ¹	8	NIM Slot 2
9	NIM Removable Divider	10	NIM Slot 1
11	SFP/RJ45 Ports		

1. Gi0/0 may be configured to be either copper or fiber. Gi0/1 is copper/RJ45 and Gi0/2 is Fiber/SFP.

Overview of the SSD Carrier Card NIM (NIM-SSD)

This section describes the NIM-SSD and how to remove and replace NIM-SSDs. This section contains the following sections:

- [Overview, page 6-10](#)
- [Solid State Drives, page 6-14](#)
- [Installing the SSD Drives into the NIM Carrier Card, page 6-16](#)
- [Removing the SSD Drives from the NIM-SSD, page 6-17](#)
- [Removing and Replacing the Cisco NIM-SSD or NIM-HDD, page 6-21](#)
- [Installing and Removing DDR DIMMs, page 6-24](#)

Overview

The solid state drive (SSD) carrier card network interface module (NIM) enables SSD support on the platform NIM slots. It provides flash storage to the platform and supports dual 2.5” (7mm max) SATA SSDs. The carrier card fits into the NIM slots in the router. The router supports only a single SSD Carrier Card NIM.



Note

Please refer to the “Network Interface Modules” section of the [Software Configuration Guide for the Cisco 4000 Series ISRs](#) for configuration information on the SSD carrier card NIM.

The SSD carrier card NIM ([Figure 6-5](#)) has the following features:

- Single-wide NIM form factor
- LEDs for module and driver status
- On board PCIe x1 Gen 2(5G) dual-port SATA controller
- Supports SFF 2.5” SATA2 or SATA3 (7mm or less) SSDs (
- Supports module online insertion and removal (OIR)—You can remove it from a bay and insert it into a bay while the router is running
- The NIM-SSD is supported in any bay in slot 0

- Only one NIM-SSD module per router is supported

Figure 6-5 shows the front panel of the SSD NIM.

Figure 6-5 Front Panel of the SSD Carrier Card NIM

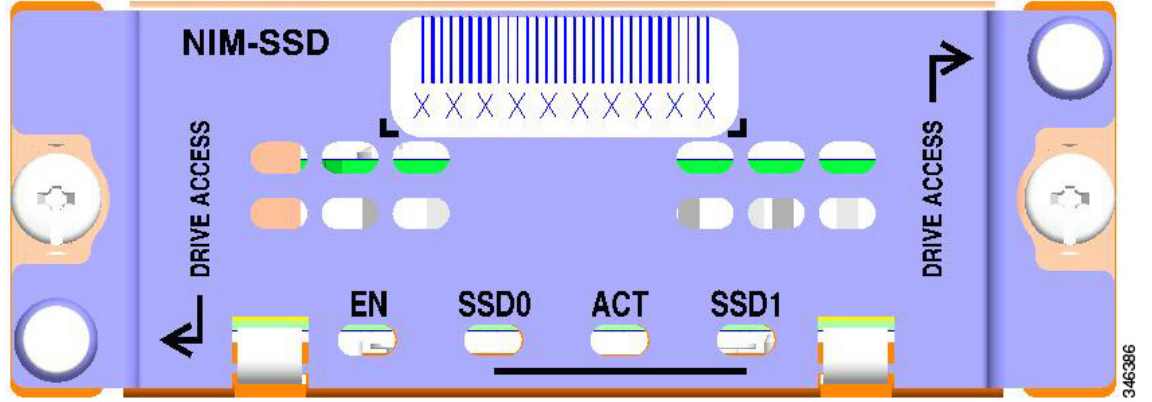

LEDs on the NIM-SSD

Table 6-2 describes the LEDs on the NIM-SSD as shown in Figure 6-5.

Table 6-2 SSD Drive LEDs

LED	Represents	Color	Description
EN	Module power	Green	Module is powered on.
		Off	Module power is off.
SSD0	Solid state drive in slot 0	Green	SSD present.
		Off	No SSD drive in slot 0.
ACT	SSD activity	Green	Activity in the SSD drive.
		Off	No activity.
SSD1	Solid state drive in slot 1	Green	SSD present.
		Off	No SSD in slot 1.

Figure 6-6 shows the rear view of the SSD carrier card NIM. This end fits into the router.

Figure 6-6 Rear View of the SSD Carrier Card NIM

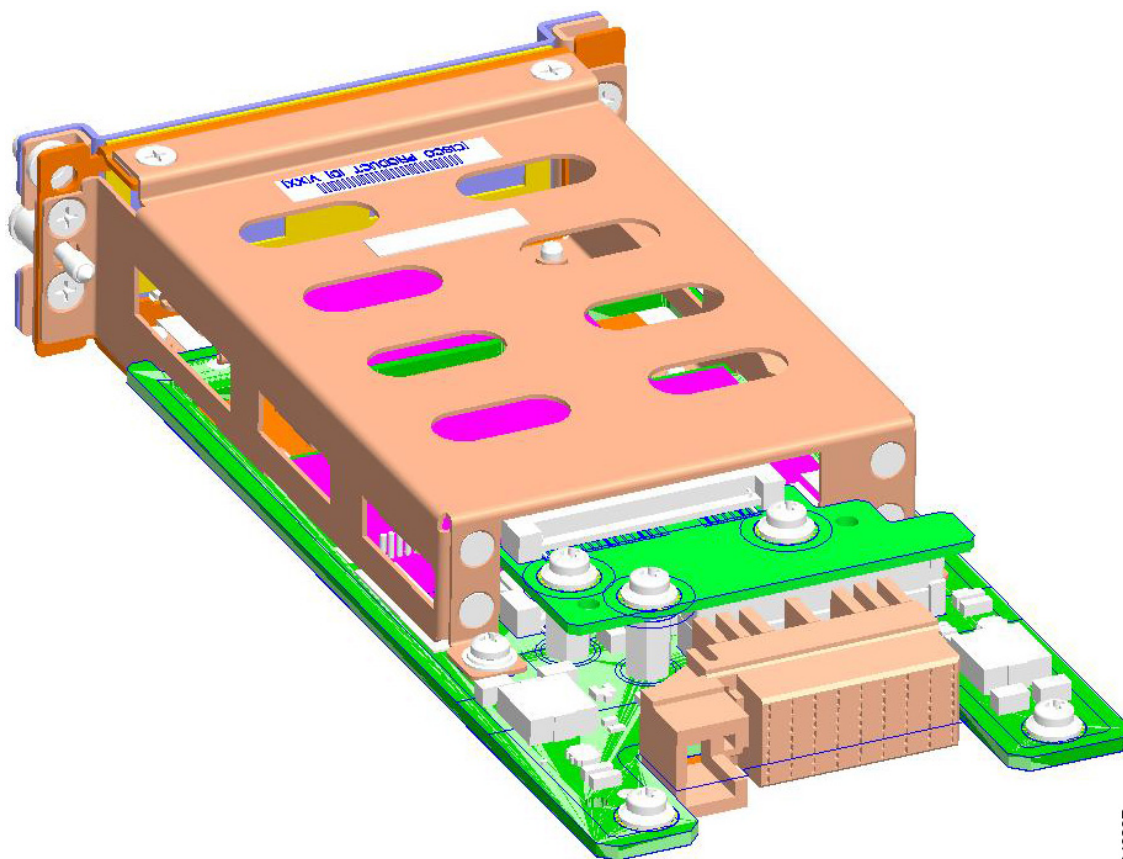

346387

Table 6-3 lists the specifications of the SSD Carrier Card NIM.

Table 6-3 Specifications of the NIM-SSD

Description	Specification
Physical	
Dimensions (H x W x D)	1.5 x 3.5 x 7.5 in (3.8 x 8.9 x 19.1 cm).
Weight	1.0 lbs (0.454 kg)
Power	
Power consumption (maximum)	20W
Environmental	
Operating humidity	10 to 85% operating
Operating altitude maximum	<ul style="list-style-type: none"> 104°F (40°C) at sea level 104°F (40°C) at 6,000 ft (1,800m)
	 <p>Note De-rate 2.5°F (1.4°C) per 1,000 ft above 6,000 ft (per 300m above 2,600m)</p>
Transportation and Storage	
Temperature	4 to 149°F (-20 to +65°C)
Relative humidity	5 to 95%
Altitude	15,000 ft (4,600m)

Figure 6-7 shows the top of the SSD carrier card NIM along with the serial number and label location.

Figure 6-7 Top View of the SSD Carrier Card NIM with Serial Number

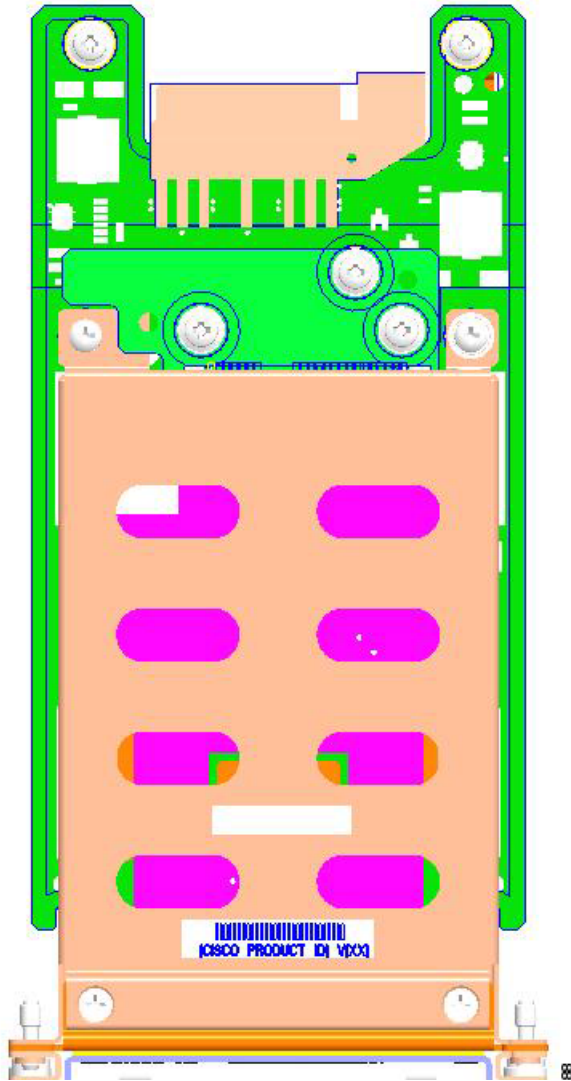

Solid State Drives

The routers contain two solid state drives (SSD) that provide nonvolatile storage in the form of an internal flash disk. On the front panel of the router, the SSD LED indicates activity on the hard drive.

The SSD carrier card NIM can support up to two SFF 2.5" SATA2 or SATA3 (7mm or less) SSDs.

Figure 6-8 shows a top view of the SSD drive that can be inserted into a NIM carrier card. Figure 6-9 shows two SSDs in a NIM carrier card.

Figure 6-8 Solid State Drive



Figure 6-9 NIM-SSD with Two Solid State Drives

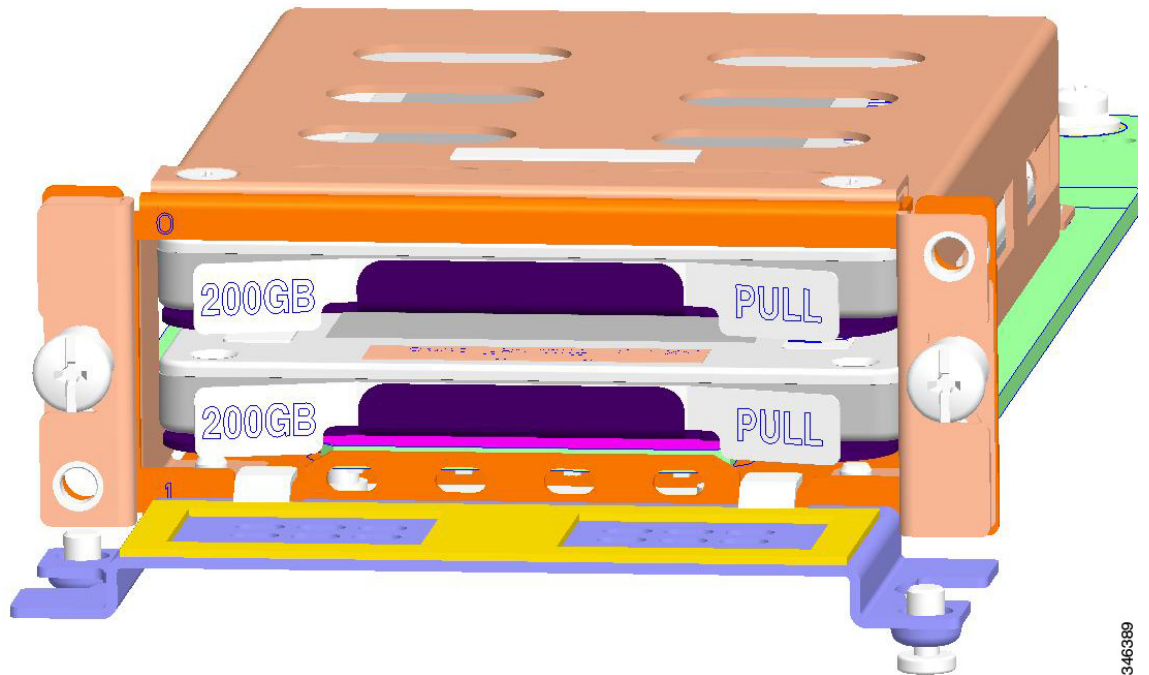
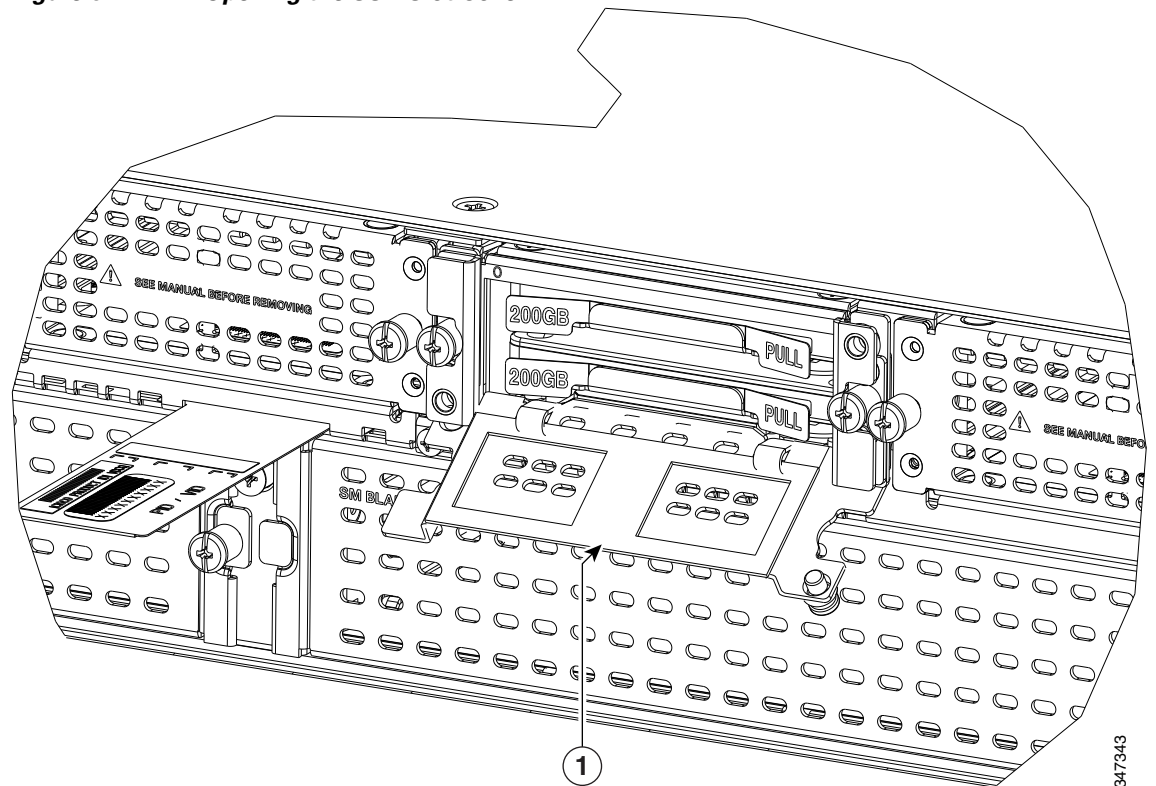

Figure 6-11 Opening the SSD Slot Cover



1	Carrier card slot cover
---	-------------------------

- Step 3** Insert an SSD in the lower slot first.
- Step 4** The SSD should be inserted connector end first with the connector side down and serial number facing up (Figure 6-8).
- Step 5** A second SSD may be inserted in the upper slot as shown in Figure 6-9.
- Step 6** Rotate the SSD card slot cover up and place into over the SSD's.
- Step 7** Re-tighten the captive fasteners on the SSD card slot cover.

Removing the SSD Drives from the NIM-SSD

To remove the SSD cards from the NIM carrier, follow these steps:



Note

Prior to removing the NIM-SSD card should be powered off by using by using the **hw-module subslot slot / subslot stop** command in EXEC mode.

- Step 1** On the NIM-SSD, loosen the captive screws retaining the NIM-SSD slot cover.
- Step 2** Rotate the SSD card slot cover down, exposing the slots which hold the SSDs.

Figure 6-13 Side View of the NIM-SSD

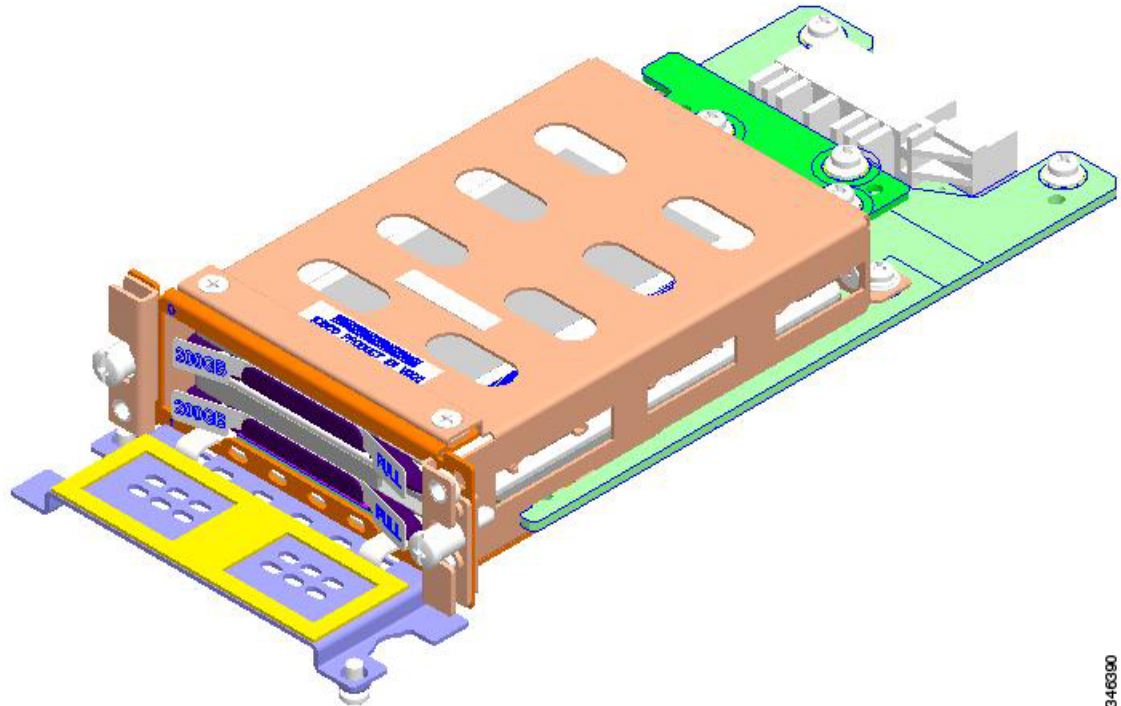

To insert or remove the NIM-SSD into any router NIM slot, see the “[Removing and Replacing the Cisco NIM-SSD or NIM-HDD](#)” section in this chapter.

Overview of the NIM-HDD Card

The NIM-HDD is a network interface module which is used to support hard disk drive (HDD) connection for the Cisco ISR 4400 and Cisco ISR 4300 routers.

The NIM-HDD module has the following features:

- Provides 1 TB of memory.
- The NIM form-factor supports and houses a single field replaceable 15 mm HDD or two SSDs.
- On-board PCIe dual channel SATA controller enabling the NIM-HDD in any NIM slot of the router (Controller Mode)
- Support for SATA pass-through mode
- Support for module level OIR operation
- Support for hot plug of SSD/HDDs



Note

A drive is removable or insertable when the power is running on the SSD/HDD connector.

- On-board Quack2 for module authentication
- Power and reset
- Firmware upgrade

**Note**

The removal of a drive during active read-write operation is not supported. You must confirm that the drive is shutdown before you replace the NIM-HDD.

Figure 6-14 shows the HDD card that can be inserted into the NIM chassis shown in Figure 6-15. Figure 6-16 shows the entire Cisco NIM-HDD.

Figure 6-14 HDD Card

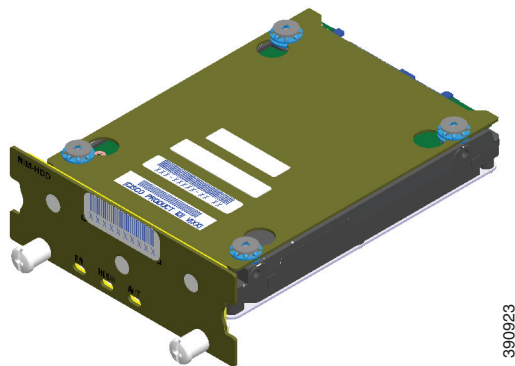

390923

Figure 6-15 NIM Chassis for the HDD

Figure 6-16 HDD in the NIM Chassis

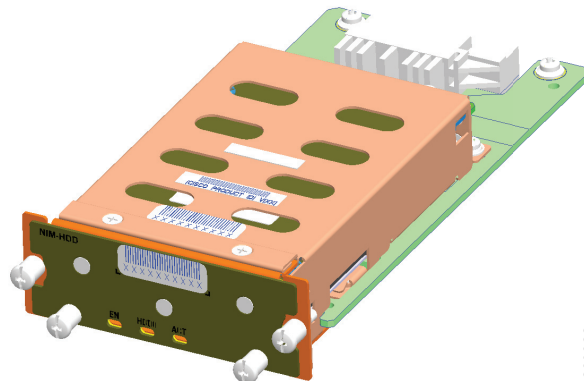

390923

Cisco NIM-HDD LEDs

Table 6-4 shows the LED description for the NIM-HDD.

Table 6-4 LED Description for NIM-HDD

LED	Color	Description
EN (Enabled)	Green	The module is powered on and is functioning correctly.
	Amber	Module has some failure.
	Off	Default when module is powered on for the first time. Persistent until changed by the host software.
HDD0	Green	HDD0 is present.
	Amber	Fault detected on HDD0.
HDD ACT	Green	Activity on HDD0 and HDD1
HDD1	Green	HDD1 is present.
	Amber	Fault detected on HDD1.

Removing and Replacing the Cisco NIM-SSD or NIM-HDD

This section explains how to remove a NIM-SSD or NIM-HDD from the router chassis and replace it with a new external NIM-SSD or NIM-HDD.

To deactivate and reactivate a NIM, see the “[Deactivating and Reactivating a SSD Carrier Card NIM](#)” section in the *Software Configuration Guide for the Cisco 4400 and Cisco 4300 Series ISRs*.

Restrictions

- Cisco SSD Carrier Card NIM with no SSD drives is not supported.
- Dynamically removing and inserting SSD drives on a NIM is not supported.

- Only a single SSD Carrier Card NIM per router is supported on any bay.
- Plugging additional SSD Carrier Card NIMs into a bay will power off the module.
- Power down the NIM-SSD module and wait for the power LED to turn off before removing the module or removing and replacing new SSD drives.
- Replacing any SSD drive can cause some data loss.

**Warning**

During this procedure, wear grounding wrist straps to avoid ESD damage to the card. Do not directly touch the backplane with your hand or any metal tool, or you could shock yourself. Statement 94

Before you begin, read the following important notices:

- The form-factor internal hard drive is accessible from the front panel of the Cisco ISR 4451-X and supports the online insertion and removal feature (OIR) using the following CLI commands for the standby:
 - **request platform hardware filesystem harddisk: offline**
 - To verify once the SSD drive is installed in the router, use the **show platform** command. The following example shows a sample output for a NIM SSD installed in a ISR4451-X platform:

```
Router# show platform
Chassis type: ISR4451/K9
```

Slot	Type	State	Insert time (ago)
0	ISR4452/K9	ok	15:57:33
0/0	ISR4451-6X1GE	ok	15:55:24
0/3	NIM-SSD	ok	15:55:24
1	ISR4451/K9	ok	15:57:33
1/0	SM-1T3/E3	ok	15:55:24
2	ISR4451/K9	ok	15:57:33
2/0	SM-1T3/E3	ok	15:55:24
R0	ISR4451/K9	ok, active	15:57:33
F0	ISR4451-FP	ok, active	15:57:33
P0	Unknown	ps, fail	never
P1	XXX-XXXX-XX	ok	15:56:58
P2	ACS-4450-ASSY	ok	15:56:58

Slot	CPLD Version	Firmware Version
0	12090323	15.3(01r)S [ciscouser-ISRRO...
1	12090323	15.3(01r)S [ciscouser-ISRRO...
2	12090323	15.3(01r)S [ciscouser-ISRRO...
R0	12090323	15.3(01r)S [ciscouser-ISRRO...
F0	12090323	15.3(01r)S [ciscouser-ISRRO...

- The reason you would be removing an internal hard drive is that it is failing or failed; so any data recovery may be lost.
- If the drive is functioning, you can back it up to a drive plugged into a USB port using the **archive tar** command.

Removing the NIM-SSD or NIM-HDD from the Router

To remove the module from the router, follow this procedure:

- Step 1** Slip on the ESD-preventive wrist strap that was included in the accessory kit. Loosen the screw fasteners (11) located on the SSD slots on the right of the input/output (I/O) side of the Cisco ISR 4451-X. (Figure 6-17).

Figure 6-17 Removing the NIM-SSD or NIM-HDD from the Router

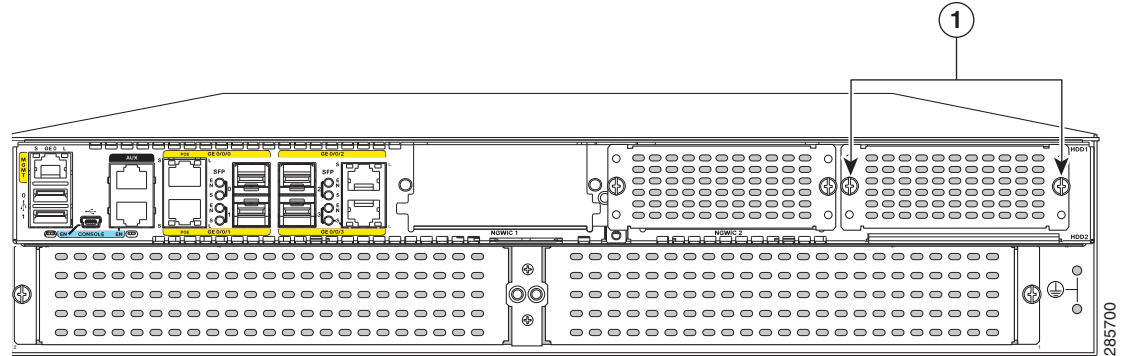

- | | |
|----------|--|
| 1 | Captive screws holding the NIM-SSD to the router |
|----------|--|

- Step 2** Using a Phillips screwdriver, loosen the captive screws on either side as shown in Figure 6-17.

Figure 6-18 Removing the NIM-SSD or NIM-HDD from the Router

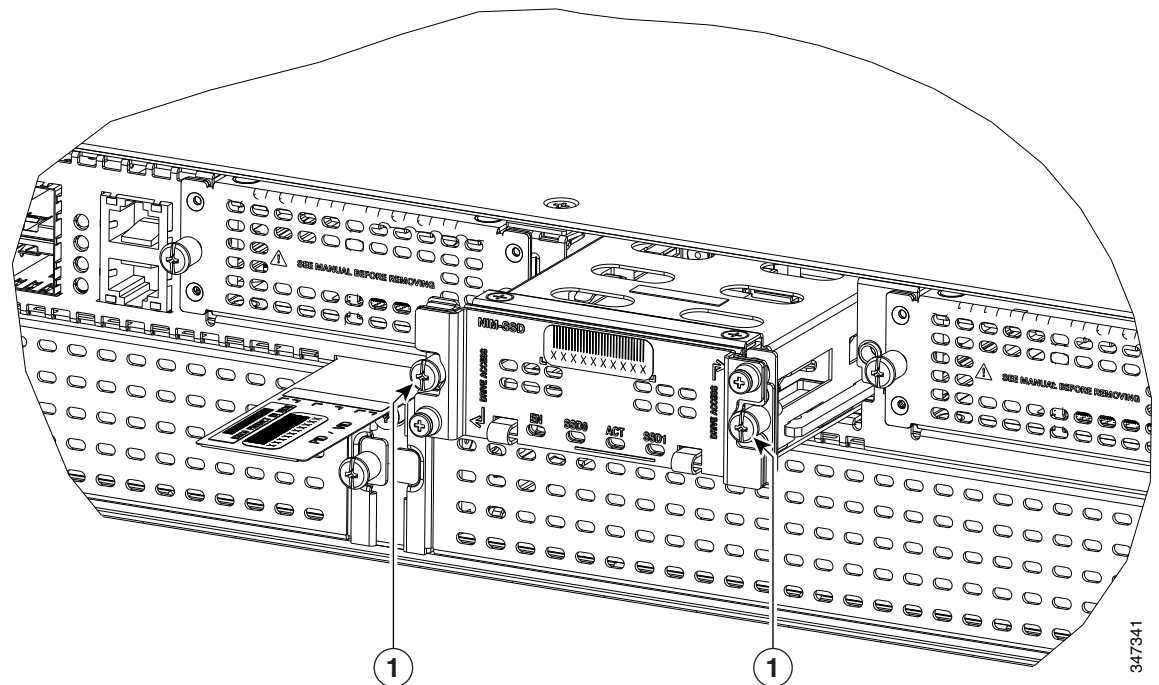

- | | |
|----------|--|
| 1 | Captive screws holding the NIM-SSD to the router |
|----------|--|

Step 3 Holding the two captive screws, slide the entire NIM unit out as shown in [Figure 6-18](#).

Replacing the NIM-SSD or NIM-HDD on the Router

To replace the NIM-SSD or the NIM-HDD on the router, follow these steps:

- Step 1** Align the NIM-SSD carrier card to the router base.
- Step 2** With two hands, slide it back into its slot in the Cisco ISR 4451-X.
- Step 3** Tighten the captive screws as shown in [Figure 6-18](#).

Installing and Removing DDR DIMMs

To access the DIMMs, you must remove the chassis cover as described in the “[Modules Supported](#)” section on page 6-4.



Caution

Always wear an ESD-preventive wrist strap and ensure that it makes good contact with your skin when you remove or install DIMMs. Connect the equipment end of the wrist strap to the metal part of the chassis.



Caution

Handle DIMMs by the edges only. DIMMs are ESD-sensitive components and can be damaged by mishandling.

Locating and Orienting DIMM

See the “[Locating Internal and External Slots for Modules on the Cisco 4451 ISR](#)” section on page 6-6 to find DIMM connectors on the router.

DIMMs have a polarization notch on the mating edge to prevent incorrect insertion. [Figure 6-19](#) shows the polarization notch on a DIMM.

Figure 6-19 DIMM Showing Polarization Notch

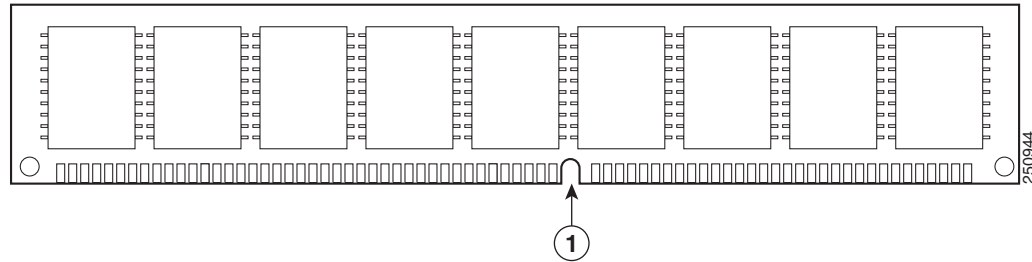

1	Polarization notch
----------	--------------------

Removing a DIMM

Follow these steps to remove a DIMM:

-
- Step 1** Read the [“Safety Warnings”](#) section on page 6-2 section and disconnect the power supply before you perform any module replacement.
 - Step 2** Remove the chassis cover. See the [“Replacing the Chassis Cover”](#) section on page 6-5.
 - Step 3** Locate the DIMM module. See the [“Locating Internal and External Slots for Modules on the Cisco 4451 ISR”](#) section on page 6-6 to find the DIMM sockets on the router.

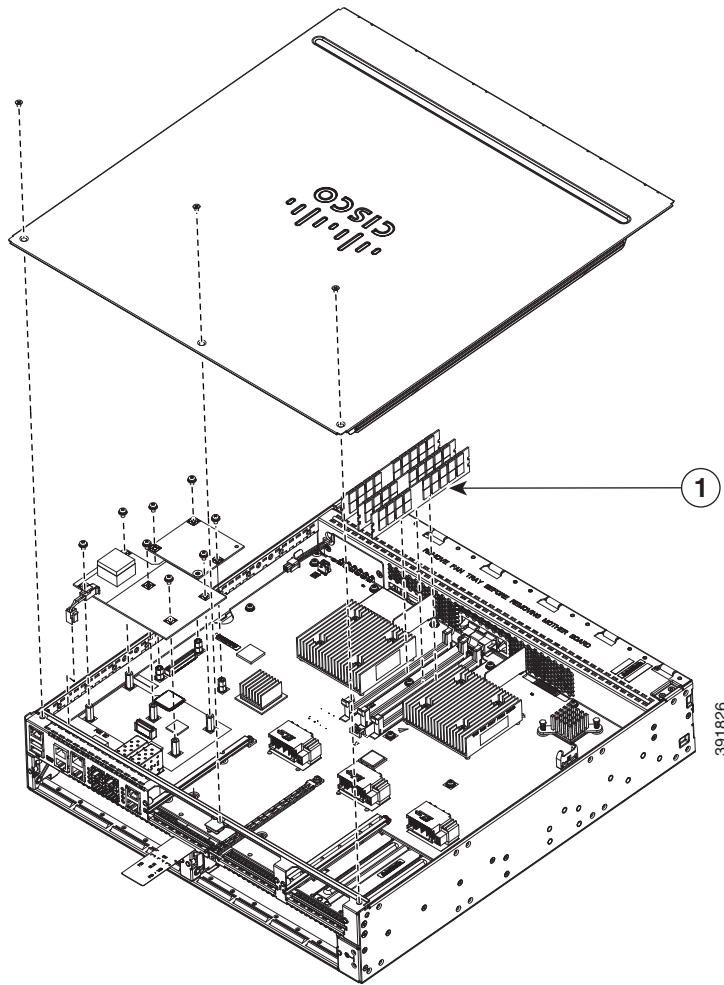

1 DIMM cards

- Step 4** Pull the latches away from the DIMM at both ends to lift the DIMM slightly. Pull the DIMM out of the socket as shown in [Figure 6-20](#).

Figure 6-20 Removing a DIMM

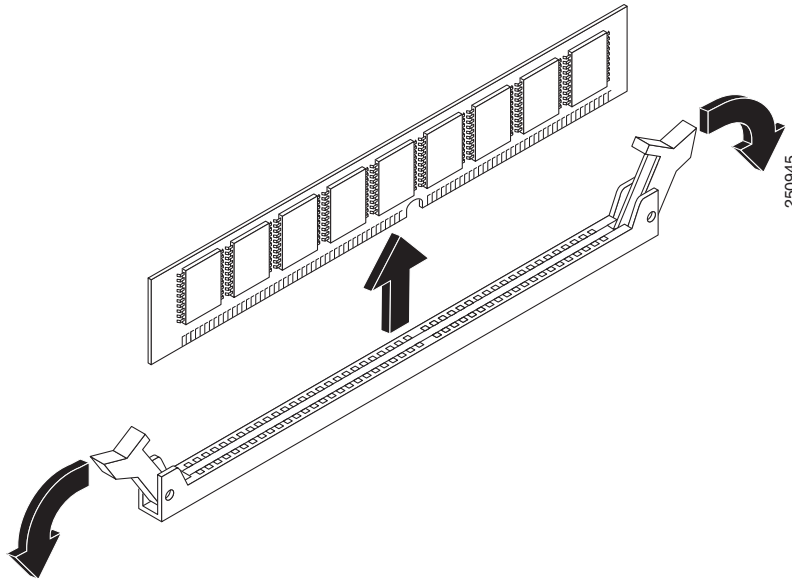

- Step 5** Place the DIMM in an antistatic bag to protect it from ESD damage.
- Step 6** Replace the chassis cover. See the [“Replacing the Chassis Cover”](#) section on page 6-5..

Installing a DIMM



Note The DIMMS on the Cisco ISR 4400 Series and Cisco ISR 4300 Series are not interchangeable.

Follow these steps to install a DIMM:

- Step 1** Read the [“Safety Warnings”](#) section on page 6-2 section and disconnect the power supply before you perform any module replacement.
- Step 2** Remove the chassis cover. For the Cisco ISR 4451-Xs, see the [“Replacing the Chassis Cover”](#) section on page 6-5.
- Step 3** Locate the DIMM module. See the [“Locating Internal and External Slots for Modules on the Cisco 4451 ISR”](#) section on page 6-6 to find the DIMM sockets on the router.
- Step 4** Make sure that both latches on the DIMM connector are in the open position.
- Step 5** Orient the DIMM so that the polarization notch lines up with the polarization key on the connector. See [Figure 6-21](#).

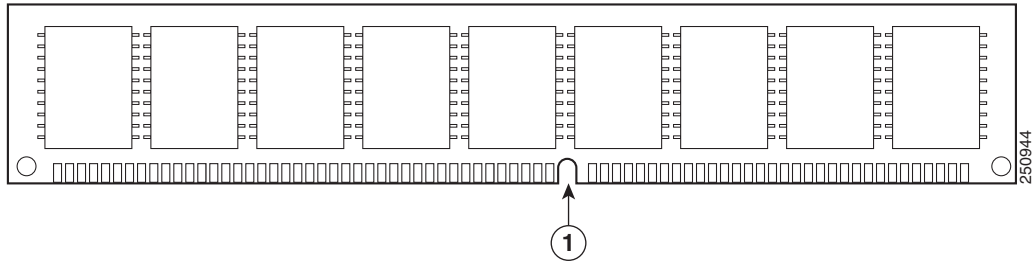
Figure 6-21 DIMM Showing Polarization Notch

Step 6 Insert the DIMM into the connector one side at a time. [Figure 6-22](#) shows what not to do while handling a DIMM.

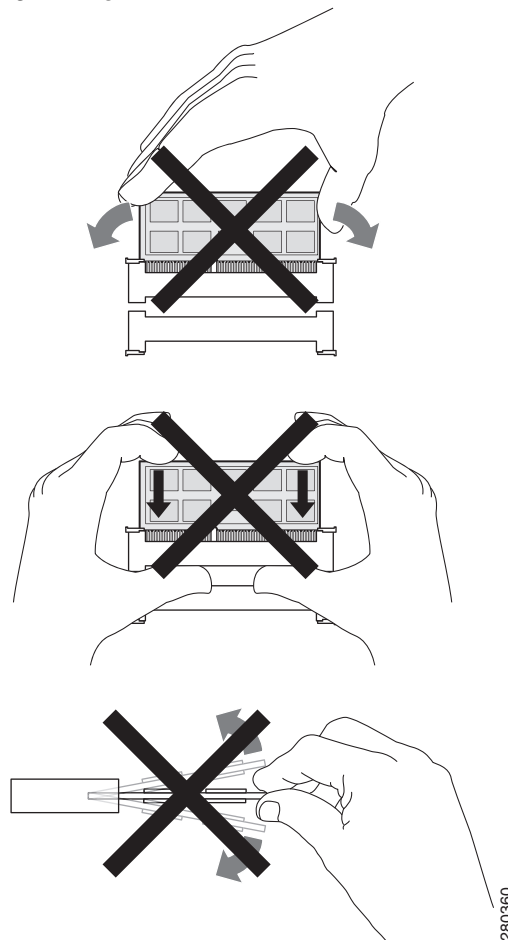
Figure 6-22 Handling the DIMMs

Step 7 Carefully and firmly press the DIMM into the connector until the latches close onto the DIMM. Make sure that both latches rotate to the closed position against the DIMM. See [Figure 6-23](#).

Figure 6-23 Installing a DIMM

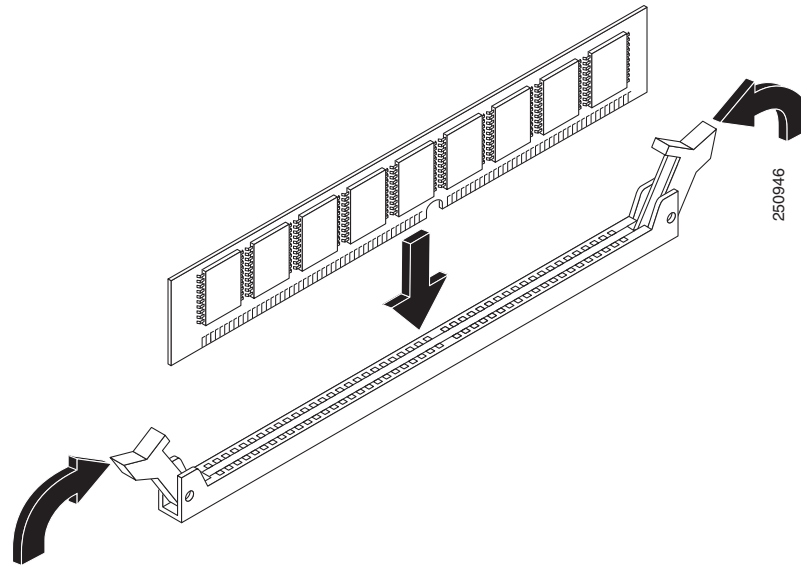

Step 8 Replace the chassis cover. See the “Replacing the Chassis Cover” section on page 6-5.

Installing and Removing NIMs and SM-Xs

Network Interface Modules (NIMs), Service Modules (SM-Xs) and the Cisco E-Series Server Modules plug into the various slots on the motherboard. SM-Xs are sold as a spare part, and they have a label that identifies the SM-X type. See the following sections for SM-X installation tasks:



Note

The procedures in this section apply to NIMs, SM-Xs, and the Cisco E-Series Server modules.

- [Software Requirement for SM-Xs, page 6-30](#)
- [Locating an SM-X or NIM, page 6-30](#)
- [Removing an SM-X or NIM, page 6-30](#)
- [Installing an SM-X, page 6-30](#)
- [Verifying SM-X Installation, page 6-31](#)



Caution

Always wear an ESD-preventive wrist strap and ensure that it makes good contact with your skin when you remove or install an SM-X. Connect the equipment end of the wrist strap to the metal part of the chassis.



Caution

Handle SM-Xs and NIMs by the edges only. SM-Xs are ESD-sensitive components and can be damaged by mishandling.

Software Requirement for SM-Xs

Cisco IOS XE software of a specified release or later release is required for using an SM-X.

To determine the version of Cisco IOS software that is running on your router, log in to the router and enter the **show version** command:

```
Router> show version
```

```
Cisco Internetwork Operating System Software
4400 Software (C4400-ADVENTERPRISEK9-M), Version 12.3(8.2)T, INTERIM SOFTWARE
```

Locating an SM-X or NIM

See the “[Locating Internal and External Slots for Modules on the Cisco 4451 ISR](#)” section on page 6-6 to locate the SM-X or NIM slot on the motherboard.

Removing an SM-X or NIM

Use the following procedure to remove an SM-X:

-
- Step 1** Read the “[Safety Warnings](#)” section on page 6-2 and disconnect the power supply before you perform any module replacement.
 - Step 2** Access the SM-X slot. See [Figure 6-2](#) for the various NIM and SM-X slot locations.
 - Step 3** Loosen the captive screws to open the slot cover. See [Figure 6-10](#) and [Figure 6-11](#).
 - Step 4** Pull the SM-X out of the connector on the motherboard. Keep the SM-X parallel with the motherboard to prevent damage to the slot and standoff.
 - Step 5** Place the SM-X in an antistatic bag to protect it from ESD damage.
-

Installing an SM-X

To install an SM-X, use a number 2 Phillips screwdriver or flat-blade screw drive, and a 1/4-inch nut driver or wrench.

-
- Step 1** Read the “[Safety Warnings](#)” section on page 6-2 and disconnect the power supply before you perform any module replacement.
 - Step 2** Identify the SM-X slot you will insert the SM-X into.
 - Step 3** Loosen the captive screws to open the slot cover. See [Figure 6-10](#) and [Figure 6-11](#).
 - Step 4** Insert the SM-X to the system board.



Note Be sure to press firmly on the SM-X until the board seats onto the connector.

- Step 5** Insert the screws from the accessory kit through the SM-X into the standoffs. See [Figure 6-27](#). Carefully tighten the screws with a Phillips screwdriver (torque 6 to 8 in-lb or 0.7 to 1.1 Nm.).

Step 6 Check that the SM-X is installed correctly on the system board.



Note

For more details on installation of SM-Xs, NIMs, and Cisco E-Series Server Modules, see the hardware installation guide for the particular module you have purchased.

For a list of links to all the SM-Xs and NIMs supported on your router, see the [Documentation Roadmap for the Cisco 4000 Series ISRs](#).

Verifying SM-X Installation

Use the **show diag** command to verify that the SM-X has been installed correctly. In the following example, one SM-X is recognized by the system.

```
router#show diag ?
  all           All related information
  chassis      Chassis related information
  slot         Slot location information for this command
  subslot      Subslot location information for this command

Router#show diag subslot 2/0 eeprom detail
SPA EEPROM data for subslot 2/0:

      EEPROM version           : 4
      Compatible Type          : 0xFF
      Controller Type          : 1909
      Hardware Revision        : 1.0
      PCB Part Number          : 73-14154-02
      Top Assy. Part Number     : 800-36532-01
      Board Revision           : 06
      Deviation Number         : 123598
      Fab Version               : 02
      PCB Serial Number        : FOC15495HU1
      Asset ID                  : REV 2F
      Product Identifier (PID)  : SM-X-1T3/E3
      Version Identifier (VID)  : V01
      CLEI Code                 : TBD
      Base MAC Address          : C4 0A CB 56 00 99
      MAC Address block size    : 3
      Manufacturing Test Data   : 00 00 00 00 00 00 00 00
      Environment Monitor Data  : 40 0B E3 43 00 0A
      Platform features         : 02 01 01 0A 00 00 00 00
                                01 01 00
```

Installing and Removing the PVDM4

This section describes the installation tasks for the PVDM4 used on the router, and it contains the following subsections:

- [Tools and Equipment Required](#)
- [Installing the PVDM4 on the Cisco Fourth-Generation T1/E1 Voice and WAN NIM](#)
- [Removing the PVDM4 from the Cisco Fourth-Generation T1/E1 Voice and WAN NIM](#)

Tools and Equipment Required

You will need the following tools and equipment while working with PVDM4:

- Number 1 Phillips screwdriver or a small flat-blade screwdriver
- ESD-preventive wrist strap
- (For routers using DC power) Tape to secure DC circuit breaker handle

PVDM4 Location and Orientation

The PVDM4 connector is located on the motherboard. [Figure 6-24](#) shows the PVDM4, screws, and connector. The connector on the PVDM4 must align with the corresponding connector on the motherboard.

Figure 6-24 View of PVDM4 Connector and Screws

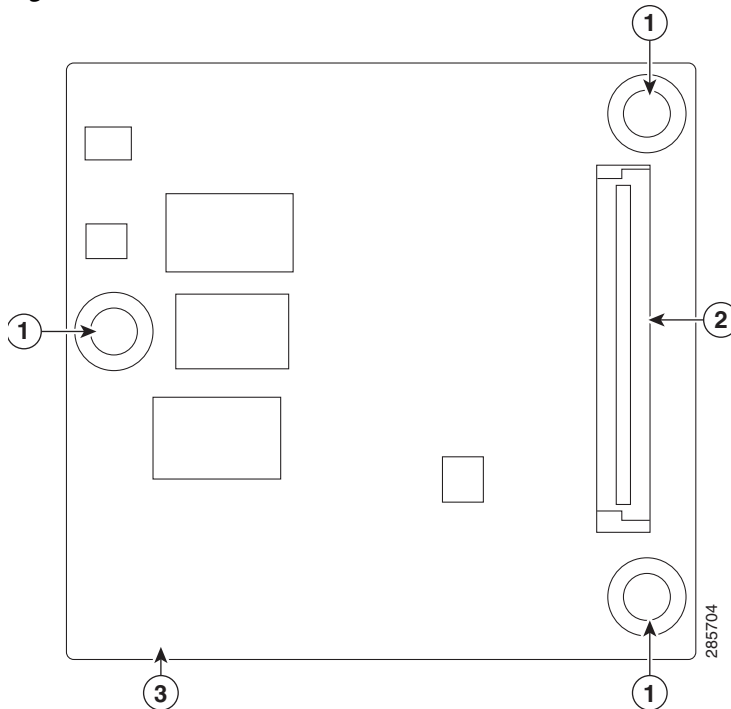

Installing the PVDM4 on the Motherboard of the Router

-
- Step 1** Read the “[Safety Warnings](#)” section on [page 6-2](#) and disconnect the power supply before you perform any module replacement.
- Step 2** Turn off electrical power to the router. Leave the power cable plugged in to channel ESD voltages to ground.
- Step 3** Remove the cover.
- Step 4** Identify the ISC slot on the router’s main motherboard.
- Step 5** Locate the three standoffs from the motherboard. See [Figure 6-25](#).
- Step 6** Insert the PVDM4 into the ISC slot on the system board.



Note Be sure to press firmly on the PVDM4 until the board seats onto the connector.

- Step 7** Insert the screws from the accessory kit through the PVDM4 into the standoffs. Carefully tighten the screws with a Phillips screwdriver (torque 6 to 8 in-lb. or 0.7 to 1.1 Nm).
- Step 8** Check that the PVDM4 is installed correctly on the system board.
- Step 9** Replace the cover.
-

**Caution**

When you remove or install the PVDM4, always wear an ESD-preventive wrist strap, and ensure that it makes good contact with your skin. Connect the equipment end of the wrist strap to the metal part of the chassis.

**Caution**

Handle the PVDM4 by the edges only. PVDM4s are ESD-sensitive components and can be damaged by mishandling.

**Warning**

No user-serviceable parts inside. Do not open. Statement 1073

**Warning**

Only trained and qualified personnel should be allowed to install, replace, or service this equipment. Statement 1030

Removing the PVDM4 from the Motherboard of the Router

- Step 1** Turn off electrical power to the router. Leave the power cable plugged in to channel ESD voltages to ground.
- Step 2** Remove the router cover.
- Step 3** Locate the PVDM4 on the motherboard. See [Figure 6-25](#).

Figure 6-25 Location of PVDM4 on the Cisco ISR 4451-X

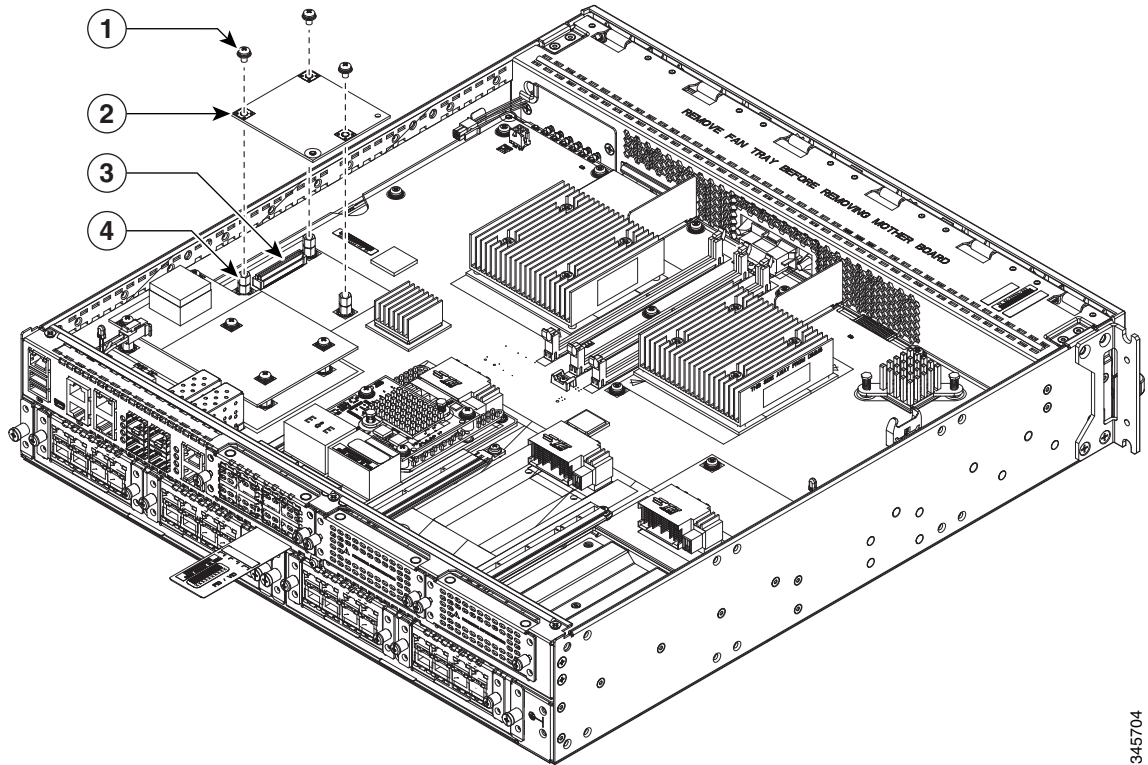

1	Screws	2	PVDM4
3	Connector	4	Standoffs

- Step 4** Loosen and remove the three screws on the PVDM4.
- Step 5** Lift the PVDM4 up from the motherboard.
- Step 6** Place the PVDM4 in an anti-static bag.
- Step 7** Replace the cover.

Installing the PVDM4 on the Motherboard of the Cisco 4331 ISR Router

-
- Step 1** Read the “[Safety Warnings](#)” section on [page 6-2](#) and disconnect the power supply before you perform any module replacement.
- Step 2** Turn off electrical power to the router. Leave the power cable plugged in to channel ESD voltages to ground.
- Step 3** Remove the cover.
- Step 4** Identify the ISC slot on the router’s main motherboard.
- Step 5** Locate the three standoffs from the motherboard. See [Figure 6-26](#).
- Step 6** Insert the PVDM4 into the ISC slot on the system board.



Note Be sure to press firmly on the PVDM4 until the board seats onto the connector.

- Step 7** Insert the screws from the accessory kit through the PVDM4 into the standoffs. Carefully tighten the screws with a Phillips screwdriver (torque 6 to 8 in-lb. or 0.7 to 1.1 Nm).
- Step 8** Check that the PVDM4 is installed correctly on the system board.
- Step 9** Replace the cover.
-

**Caution**

When you remove or install the PVDM4, always wear an ESD-preventive wrist strap, and ensure that it makes good contact with your skin. Connect the equipment end of the wrist strap to the metal part of the chassis.

**Caution**

Handle the PVDM4 by the edges only. PVDM4s are ESD-sensitive components and can be damaged by mishandling.

**Warning**

No user-serviceable parts inside. Do not open. Statement 1073

**Warning**

Only trained and qualified personnel should be allowed to install, replace, or service this equipment. Statement 1030

Removing the PVDM4 from the Motherboard of the Cisco 4331 ISR Router

- Step 1** Turn off electrical power to the router. Leave the power cable plugged in to channel ESD voltages to ground.
- Step 2** Remove the router cover.
- Step 3** Locate the PVDM4 on the motherboard. See [Figure 6-26](#).

Figure 6-26 Location of PVDM4 on the Cisco 4331 ISR

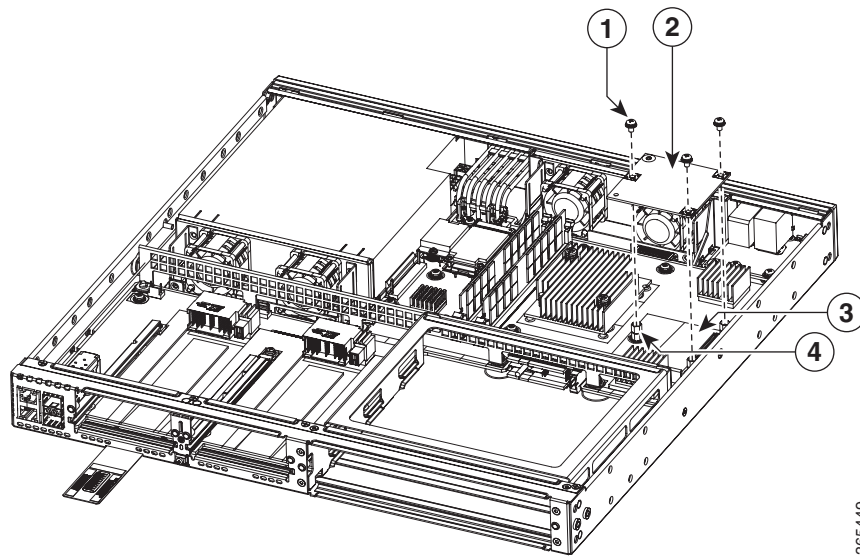

365449

1	Screws	2	PVDM4
3	Connector	4	Standoffs

- Step 4** Loosen and remove the three screws on the PVDM4.
- Step 5** Lift the PVDM4 up from the motherboard.
- Step 6** Place the PVDM4 in an anti-static bag.
- Step 7** Replace the cover.

Installing the PVDM4 on the Cisco Fourth-Generation T1/E1 Voice and WAN NIM

- Step 1** Shut down the electrical power to the slot in the router by either turning off the electrical power to the router or by issuing the online insertion and removal (OIR) commands. Leave the power cable plugged in to channel ESD voltages to ground. For more information on OIR, see the Appendix, “Online Insertion and Removal (OIR) and Hot-Swapping”.
- Step 2** Loosen the two captive screws on the network interface module.
- Step 3** Remove the network interface module. (See [Figure 6-27](#).)

Figure 6-27 Network Interface Module with PVDM4

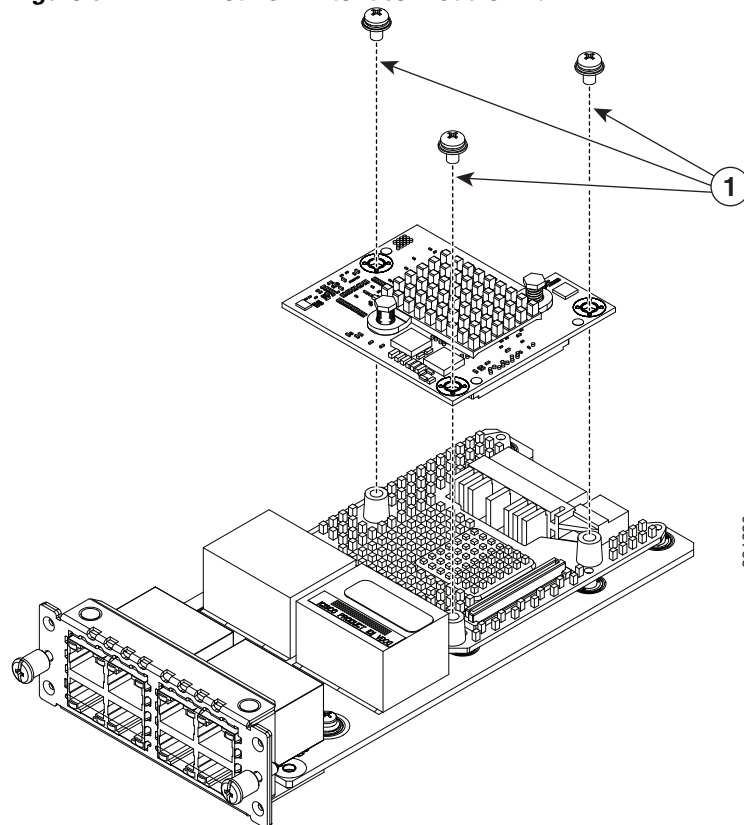

1	Captive Screws
----------	----------------

- Step 4** Locate the three standoffs on the network interface module where the PVDM4 will reside.
- Step 5** Align the PVDM4 with the connector and the standoffs and attach the PVDM4 with the three screws.
- Step 6** Slide the network interface module back in the router and tighten the captive screws.

Removing the PVDM4 from the Cisco Fourth-Generation T1/E1 Voice and WAN NIM

-
- Step 1** Shut down the electrical power to the slot in the router by either turning off the electrical power to the router or by issuing the online insertion and removal (OIR) stop command. Leave the power cable plugged in to channel ESD voltages to ground. For more information on OIR, see the [“OIR Procedures” section on page A-2](#).
 - Step 2** Loosen the two captive screws on the network interface module.
 - Step 3** Remove the network interface module with the PVDM4. (See [Figure 6-27](#).)
 - Step 4** Loosen the three screws and standoffs on the PVDM4.
 - Step 5** Lift the PVDM4 up from the network interface module.
 - Step 6** Place the PVDM4 in an anti-static bag.
 - Step 7** If you are not immediately replacing the network module, install the blank cover over the empty network module slot.
 - Step 8** Slide the network interface module back in the router and tighten the captive screws.
-

Removing and Replacing the USB Flash Token Memory Stick

The Cisco 4000 Series ISRs contain ports for a 1 GB flash token memory stick to store configurations or Cisco IOS XE consolidated packages.



Note

Only Cisco USB Flash memory modules are supported by Cisco routers.



Caution

Do not remove a USB Flash memory module when issuing some file access command or a read/write operation to the Flash memory module when it is processing. The router might reload or the USB Flash memory module can be damaged. You can check to see if the USB activity LED on the router front panel is flashing, prior to the removal of the USB device

To remove and then replace a USB flash token memory stick from the router, follow these steps:

-
- Step 1** Pull the memory stick from the USB port.
 - Step 2** To replace a Cisco USB Flash memory stick, simply insert the module into the USB port 0 or 1 port as shown in [Figure 6-28](#). The Flash memory module can be inserted in only one way, and can be inserted or removed regardless of whether the router is powered up or not.



Note

[Figure 6-28](#) is only a sample of how the memory stick is inserted into the port and does not display the actual router faceplate.

Figure 6-28 Router Flash Token Memory Stick

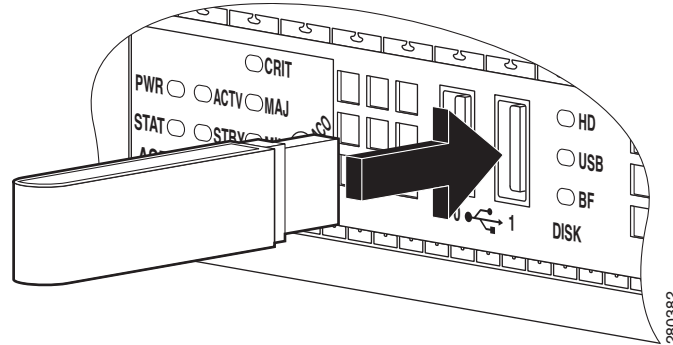

Note You can insert or remove the memory stick whether the router is powered on or not.

This completes the USB Flash memory installation procedure.

Removing and Replacing the Cisco 4000 Series ISRs Power Supplies

Some routers have replaceable power supply modules. These modular power supplies can be removed or installed using only a screwdriver.

- [AC Power Supplies](#), page 6-40
- [DC Power Supply](#), page 6-43
- [Replacing the Power Supply Module from the Cisco 4331 Router](#), page 6-48
- [PoE Converter Power Supply Unit](#), page 6-49



Warning

Blank faceplates and cover panels serve three important functions: they prevent exposure to hazardous voltages and currents inside the chassis; they contain electromagnetic interference (EMI) that might disrupt other equipment; and they direct the flow of cooling air through the chassis. Do not operate the system unless all cards, faceplates, front covers, and rear covers are in place. Statement 1029



Warning

This unit might have more than one power supply connection. All connections must be removed to de-energize the unit. Statement 1028



Warning

Care should be taken while removing the power supplies and power inverters (especially in boost mode of operation). If the total power consumption is higher than can be supported by one power supply alone and in this condition a power supply is removed, the hardware can be damaged. This may then result in the system being unstable or unusable.

AC Power Supplies

Overview of the AC Power Supply

All of the power supply have a similar modular form factor, with no cabling, for easy removal and replacement.

Figure 6-29 Power Supply Unit (Cisco ISR4451-X Shown)

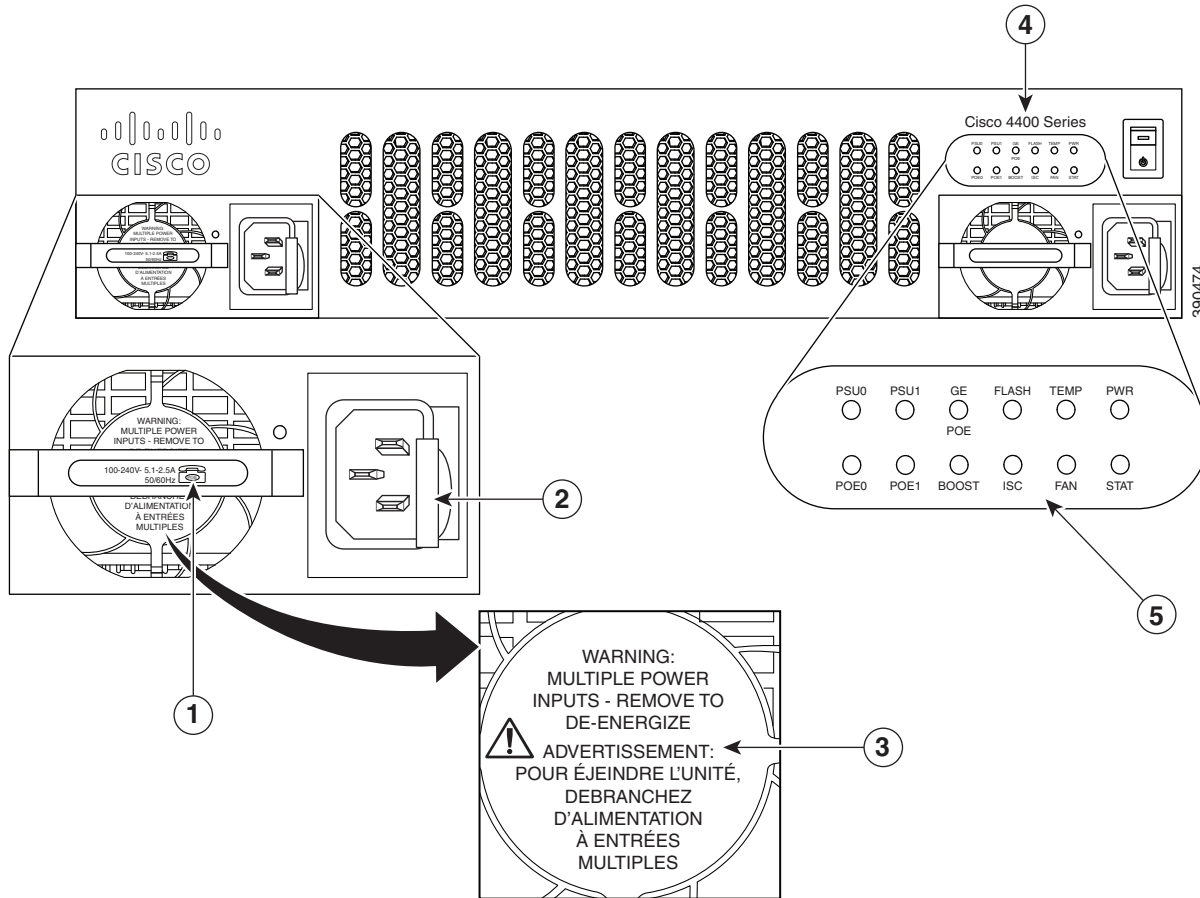

1	450W/1000W power supply (1000W shown—the phone icon designates it as a 1000W)	2	PSU Latch
3	Multiple power supply unit warning message—appears when there are multiple power inputs	4	Product series name
5	LEDs		

1. 450W/1000W power supply (1000W shown—the phone icon designates it as a 1000W)	2. PSU Latch
3. Multiple power supply unit warning message—appears when there are multiple power inputs	4. Product series
5. LEDs	

Replacing the AC Power Supply



Caution

Care should be taken while removing the power supplies and PoE power supply, especially in boost mode of operation. If the total power consumption is higher than can be supported by one PSU alone, and in this condition, if a PSU is removed, the hardware can be damaged. This may result in the system being unstable or unusable.

Similarly if there is only one PoE power supply and it is providing PoE power to an SM-X, in this condition if the PoE power supply is removed, the hardware may be damaged and may result in the system being unstable or unusable.

-
- Step 1** Read the [“Safety Warnings” section on page 6-2](#) section and disconnect the power supply before you perform any module replacement.
 - Step 2** Remove the router bezel. The bezel is secured with snap latches. To remove the bezel, hold the top and bottom and pull the bezel.
 - Step 3** Pull on the quick-release catch on the side to leverage the power supply from its connector, and then slide the power supply module out of the chassis.
 - Step 4** Insert the replacement power supply module.
 - Step 5** Replace the bezel.

Figure 6-30 Cisco ISR 4451-X Power Supply Units

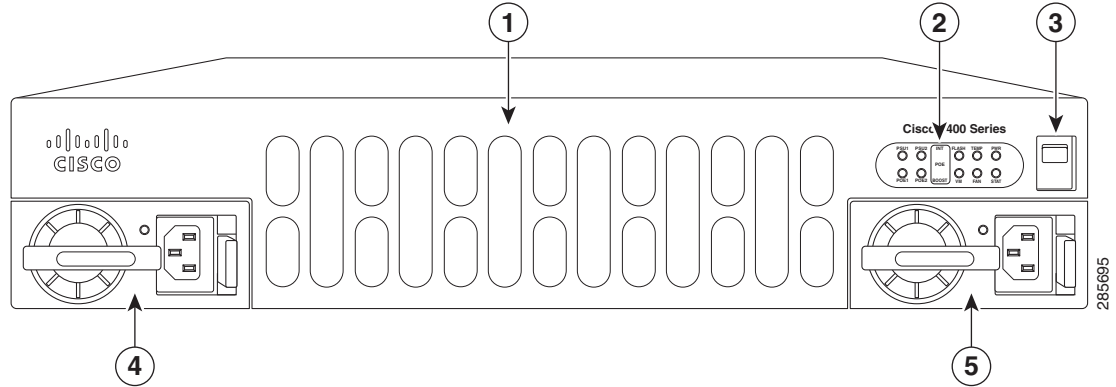

1	Router fan tray (behind the bezel)	2	LEDs
3	Router On/Off switch	4	AC power supply unit PSU0
5	AC power supply unit PSU1		

DC Power Supply

- [Overview of the DC Power Supply, page 6-43](#)
- [Removing DC Input Power from the Cisco 4431 ISR, page 6-44](#)
- [Installing DC Input Power on the Cisco 4431 ISR, page 6-45](#)
- [PoE Converter Power Supply Unit, page 6-49](#)

Overview of the DC Power Supply

The DC power supply is only supported on the Cisco 4451-X ISR, Cisco 4431 ISR, and Cisco 4351 ISR.

For the Cisco 4431 ISR, the input connector and plug must be UL recognized under UL 486 for field wiring. The connection polarity is from left to right: negative (-), positive (+), and ground.

For the Cisco 4451-X ISR and Cisco 4351 ISR, the input connector and plug must be UL recognized under UL 486 for field wiring. The connection polarity is from left to right: ground, negative (-), positive (+).

The power supply has a handle to be used for insertion and extraction. The module must be supported with one hand because of its length.

For Cisco 4431 ISR, the power supply DC input range is -48 to -60 VDC, and the maximum power is 350 W.

For Cisco 4451-X ISR and Cisco 4351 ISR, the power supply DC input range is -48 to -60 VDC, and the maximum power is 437 W.

Figure 6-31 DC Power Supply

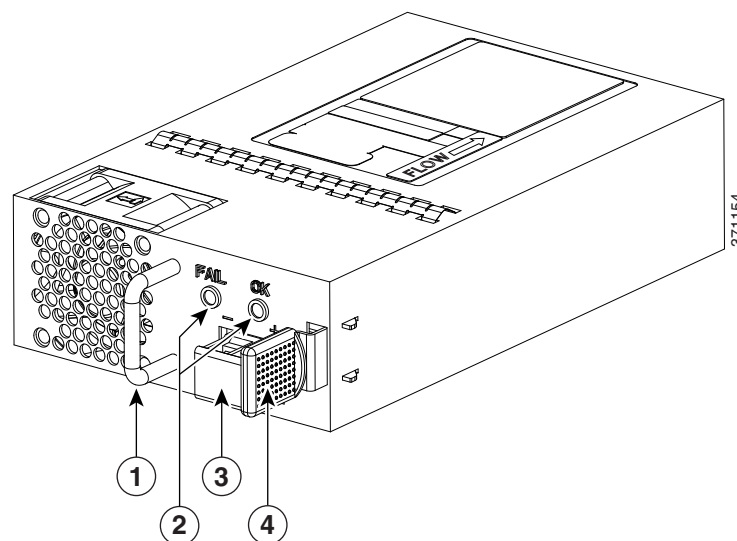

1	Handle	2	FAIL and OK LEDs
3	DC power connector	4	Ejector latch

Removing DC Input Power from the Cisco 4431 ISR

Note

The router has redundant power supplies that can be hot-swapped.

This section describes how to remove a DC power supply from the Cisco 4431 ISR. to remove a DC power supply from the Cisco 4431 ISR, follow these steps:

Step 1 If you have redundant power supplies, ensure that the power switch is in the Standby position.

Note

It is not required to place the power switch in the Standby position if you want to hot-swap a single power supply.

Step 2 For Cisco 4431 ISR, unscrew the two terminal block wire connectors (negative and positive) on the unit. See [Figure 6-35](#). ISR4451-X and ISR4351: For Cisco 4451 ISR and Cisco 4351, unscrew the three terminal block wire connectors (ground, negative and positive) on the unit.

Step 3 Remove the plastic bezel from the router. You can skip this step for Cisco 4451-X ISR and Cisco 4351 ISR.

Step 4 Press the retaining latch towards the pull handle, grasp the handle with one hand, and pull the power supply out of the slot while supporting the weight of the power supply with the other hand. See [Figure 6-32](#).

Figure 6-32 Removing DC Power Supply

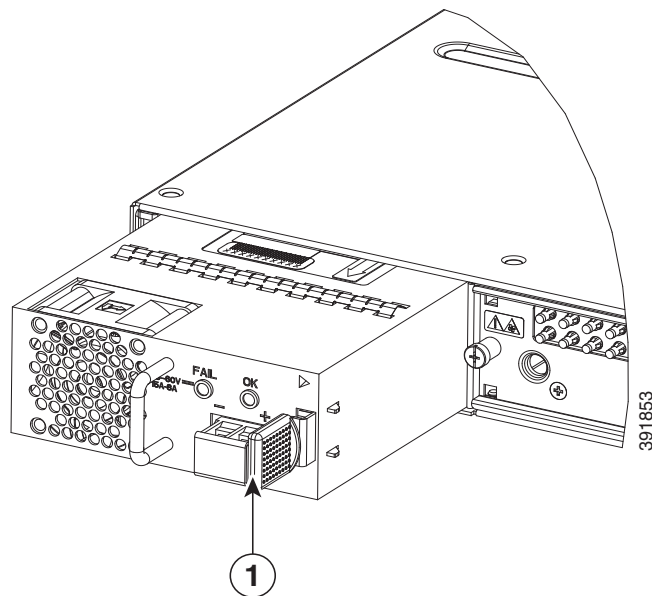

1	Retaining latch		
----------	-----------------	--	--

This completes the procedure for removing a DC power supply from the Cisco 4431 ISR.

Installing DC Input Power on the Cisco 4431 ISR



Before performing any of the following procedures, ensure that power is removed from the DC circuit.
Statement 1003



Only trained and qualified personnel should be allowed to install, replace, or service this equipment.
Statement 1030

This section describes how to install the DC power supply input power leads to the Cisco 4431 ISR Router DC input power supply. Before you begin, read these important notices:

- The color coding of the DC input power supply leads depends on the color coding of the DC power source at your site. Ensure that the lead color coding you choose for the DC input power supply matches the lead color coding used at the DC power source and verify that the power source is connected to the negative (–) terminal and to the positive (+) terminal on the power supply.
- Ensure that the chassis ground is connected on the chassis before you begin installing the DC power supply. Follow the steps provided in the “[Chassis Grounding](#)” section on page 3-22.

Wiring the DC Input Power Source

The Cisco 4431 ISR DC power supply has a terminal block that is installed into the power supply terminal block header.

To wire the DC input power source, follow these steps:

Step 1 If you have redundant power supplies, ensure that the power switch is in the Standby position.



Note It is not required to place the power switch in the Standby position if you want to hot-swap a single power supply.

Step 2 Insert the power supply in the power-supply slot, and gently push it into the slot. When correctly installed:

- For Cisco 4431 ISR, the DC power supply (excluding the extraction handle) is flush with the router.
- For Cisco 4451-X ISR and Cisco 4351ISR, the DC power supply (excluding the extraction handle) will be recessed from the router bezel.

Step 3 Wire can be stripped and terminated directly to the power supply terminal block, or a crimp style spade terminal lug can be used. If using a terminal lug follow the manufacturer's instructions for terminating the lug to the wire. If terminating directly to the terminal block using bare wire, following the below directions. Use a wire-stripping tool to strip each of the two wires coming from the DC input power source and strip the wires to approximately 0.39 inch (10 mm) ± 0.02 inch (0.5 mm). It is recommended that 14 AWG insulated wire be used. Do not strip more than the recommended length of wire because doing so could leave the wire exposed from the terminal block. [Figure 6-33](#) shows a stripped DC input power source wire.

Figure 6-33 Stripped DC Input Power Source Wire

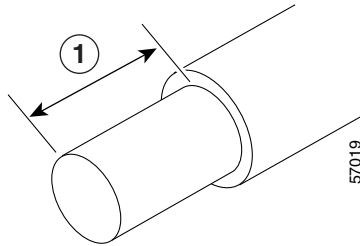

1	0.39 inch (10 mm) is the recommended wire-strip length for the terminal block.
----------	--

**Warning**

An exposed wire lead from a DC input power source can conduct harmful levels of electricity. Be sure that no exposed portion of the DC input power source wire extends from the terminal block. Statement 122

Step 4 Identify the positive and negative feed positions for the terminal block connection. The wiring sequence is:

1. Positive (+) lead wire (right)
2. Negative (-) lead wire (left)

Step 5 Remove the router bezel. See Figure 6-34. The bezel is secured with snap latches. To remove the bezel, hold the top and bottom and pull the bezel.

Figure 6-34 Removing the Bezel

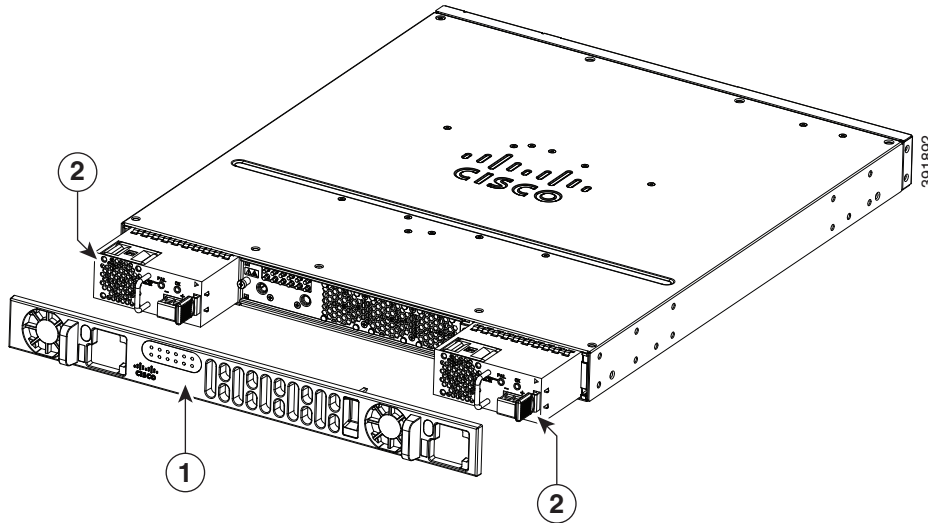

1	Bezel	2	DC power supplies
----------	-------	----------	-------------------

Step 6 Insert the wires through the holes in the bezel. Replace the bezel.

- Step 7** Insert the exposed wire into the terminal block. Ensure that you cannot see any wire lead outside the plastic cover. Only wires *with insulation* should extend from the terminal block.

**Caution**

Do not overtorque the terminal block captive screws. Ensure that the connection is snug, but the wire is not crushed. Verify by tugging lightly on each wire to ensure that they do not move.

- Step 8** Use a screwdriver to tighten the terminal block captive screws, as shown in [Figure 6-35](#).

Figure 6-35 DC Power Supply with Lead Wires

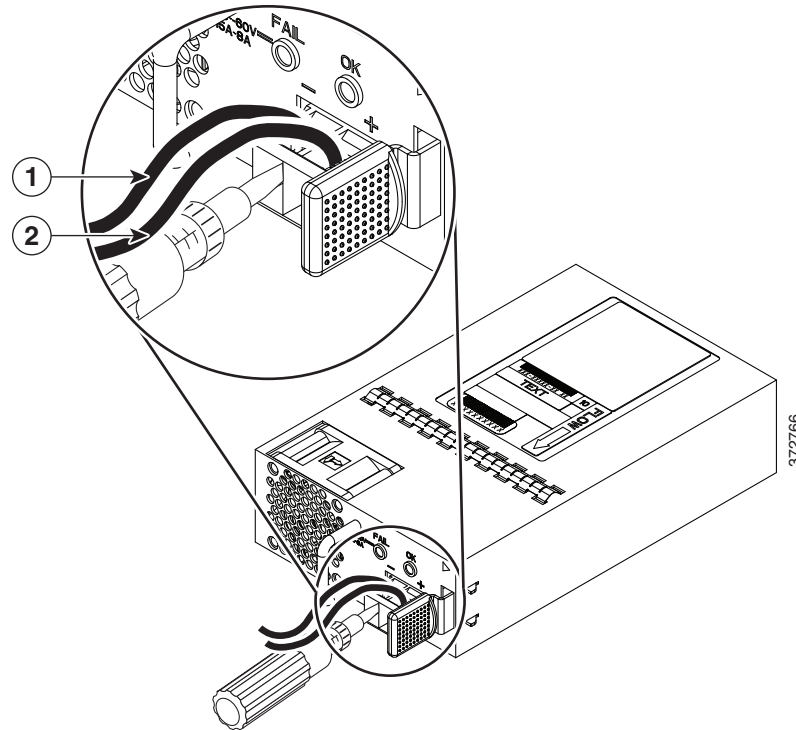

1	Negative (-) lead wire	2	Positive (+) lead wire
----------	------------------------	----------	------------------------

- Step 9** Repeat these steps for the remaining DC input power source wire as applicable.
- Step 10** Use a tie wrap to secure the wires to the rack, so that the wires are not pulled from the terminal block by casual contact.
- Step 11** Turn on the circuit breaker at the power source.
- Step 12** If you have changed the Standby switch to the standby position in step 1, turn the Standby switch to the On position.
The power supply LEDs illuminate green.

Replacing the Power Supply Module from the Cisco 4331 Router

To replace a power supply module from the Cisco 4331 router, perform these steps:

-
- Step 1** Read the [“Safety Warnings” section on page 6-2](#) section and turn off the system power before you perform the power supply module replacement.
- Step 2** Remove the four cover screws from the top of the chassis.
-  **Note** The length of the cover screw on top of the chassis is shorter.
-
- Step 3** Remove the two cover screws from each side of the chassis and lift the cover away from the router chassis. See [Figure 6-42](#).
- Step 4** Remove the fan tray. Follow the steps provided in the [“Replacing the Fan Tray on a Cisco 4331 ISR” section on page 6-55](#).
- Step 5** Remove the power supply cable connector. See [Figure 6-36](#).
- Step 6** Remove the two screws that secure the power supply module to the chassis.
- Step 7** Pull the power supply module out of the chassis using the power supply tab. See [Figure 6-36](#).
- Step 8** Insert the replacement power supply module and align the power supply module into the slot.
- Step 9** Tighten the two screws (torque 6 to 9 in-lb) that secure the power supply module to the chassis. See [Figure 6-36](#).
- Step 10** Connect the power supply cable connector.
- Step 11** Insert the fan tray and gently push down until the spring-lock is latched and fully engaged onto the slot. Follow the steps provided in the [“Replacing the Fan Tray on a Cisco 4331 ISR” section on page 6-55](#).
- Step 12** Connect the fan connectors on the motherboard. See [Figure 6-43](#).
- Step 13** Turn on the system power and verify that the power supply module is functioning normally.
- Step 14** Turn off the system power before you cover over the chassis.
- Step 15** Center the cover over the chassis and lower it onto the chassis.
- Step 16** Install the four cover screws (torque 5 to 6 in-lb) on the top of the chassis and install the two cover screws (torque 5 to 6 in-lb) on each side of the chassis. See [Figure 6-42](#).

Figure 6-36 Cisco 4331 ISR Power Supply Module



1	Power supply module	2	Screws
3	Power supply cable connector	4	Power supply module tab

PoE Converter Power Supply Unit

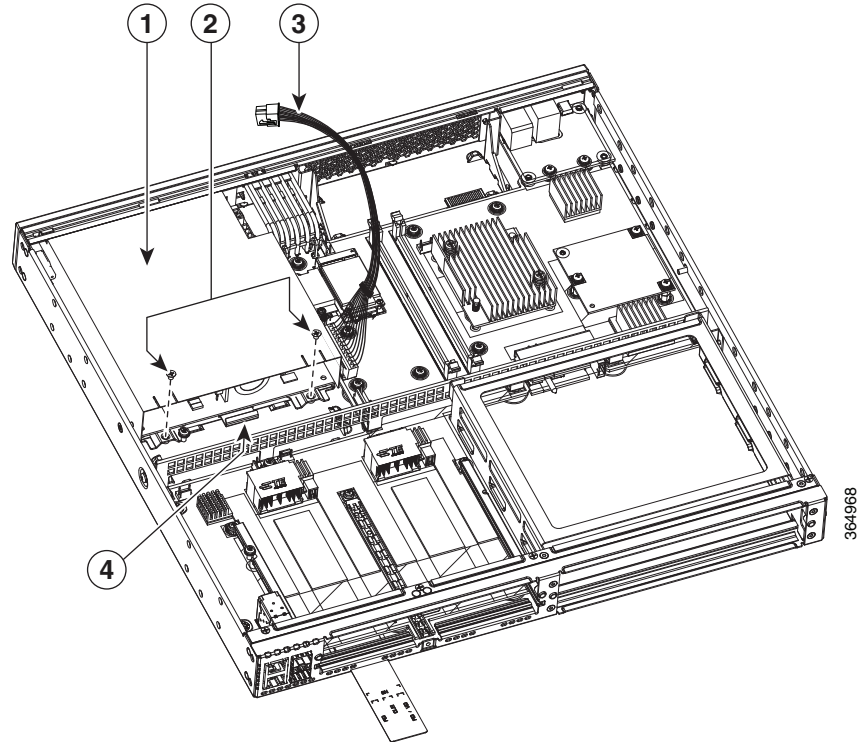
This section includes:

- [Overview of the PoE Converter Power Supply Unit, page 6-49](#)
- [Removing the PoE Power Supply Slot Filler, page 6-50](#)
- [Installing the PoE Converter Power Supply, page 6-51](#)
- [Removing the PoE Converter Power Supply, page 6-51](#)
- [Installing the PoE Power Supply Slot Filler, page 6-52](#)

Overview of the PoE Converter Power Supply Unit

The PoE converter power supply supports online insertion feature. The PoE converter power supply does not support online removal.

The optional PoE converter PSU slots come with factory-installed fillers. You must remove them to install the PoE converter power supplies.

**Note**

If using only one PoE converter power supply, you must install the PoE converter power supply in PoE slot 0.

Figure 6-37 shows the location of the PoE converter power supply slots located behind the bezel and fan tray.

Figure 6-37 Removing Bezel and Fan Tray to Locate PoE Slots

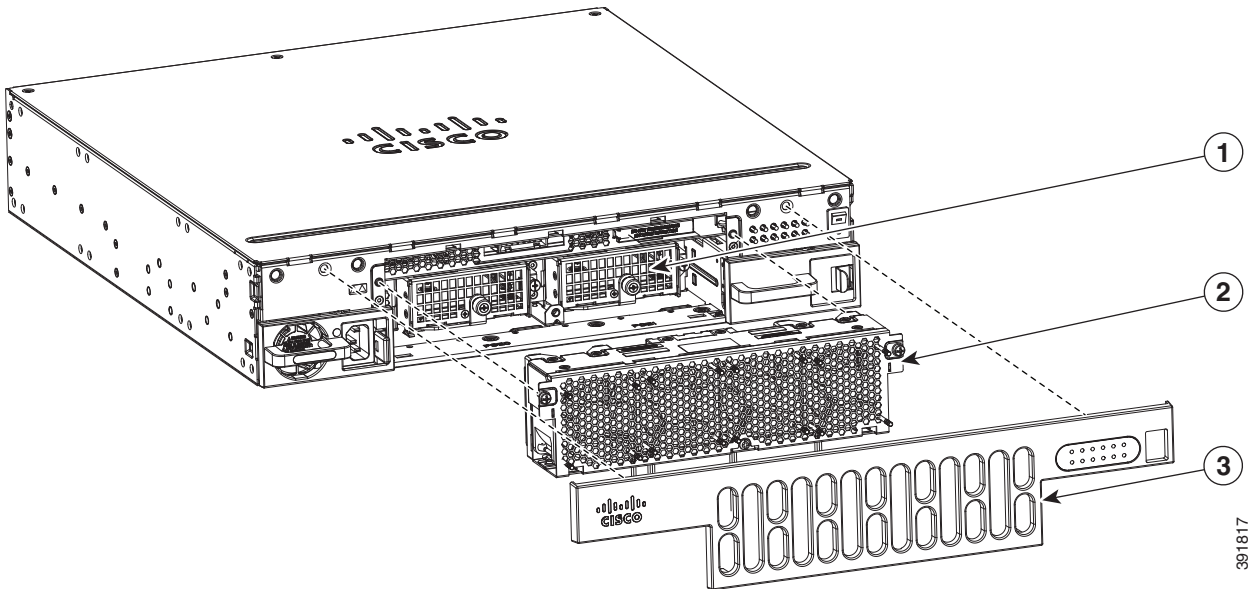

391817

1	PoE converter power supply slot	2	Fan tray
3	Bezel		

Removing the PoE Power Supply Slot Filler

To remove a PoE power supply filler, perform these steps:

- Step 1** Remove the bezel and fan tray from the router.
- Step 2** Loosen the screws from the securing nuts on the chassis. See [Figure 6-38](#) for details.
- Step 3** Gently pull out the filler from the filler tab on the chassis.

Figure 6-38 Installing or Removing PoE Fillers

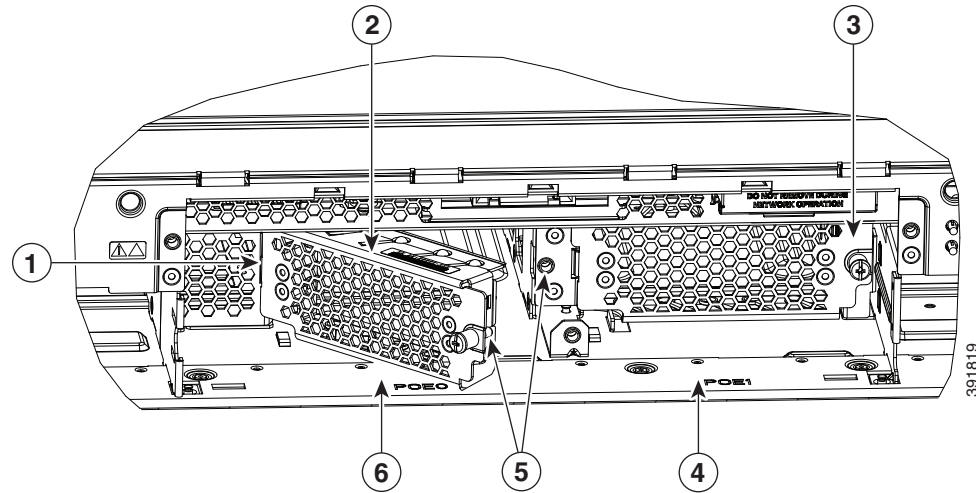

1	Install tab into slot on chassis	2	PoE filler being installed in PoE slot 0
3	PoE filler shown installed in PoE slot 1	4	PoE slot 1
5	Rotate to secure screw into securing nut in chassis	6	PoE slot 0

Installing the PoE Converter Power Supply

To install the PoE converter power supply, follow these steps:

-
- Step 1** Remove the bezel and fan tray from the router chassis. See [Replacing the Fan Tray](#), page 6-54.
 - Step 2** Remove the PoE converter power supply filler. For instructions, see “[Removing the PoE Power Supply Slot Filler](#)”.
 - Step 3** Open the slot latch before inserting the PoE converter power supply module.
 - Step 4** Rotate latch to close it.
 - Step 5** Tighten the screws on the module to secure it to the router chassis. See [Figure 6-39](#) for details.
-

Removing the PoE Converter Power Supply

To remove the PoE converter power supply, perform these steps:

-
- Step 1** Remove the bezel and fan tray from the router chassis.
Open the slot latch. See [Figure 6-39](#) for details.
 - Step 2** Remove the PoE converter power supply module.
-

- Step 3** Replace PoE converter power supply filler. See “[Removing the PoE Power Supply Slot Filler](#)” section for details.
-

After you remove the PoE converter PSU, you need to either install a replacement power or put the filler.

Installing the PoE Power Supply Slot Filler

You cannot keep the slot empty, you need to install the filler. To install a PoE power supply slot filler, perform these steps:

-
- Step 1** Remove the bezel and fan tray from the router.
- Step 2** Insert the filler tab into the slot on the chassis.
- Step 3** Tighten the screws into the securing nuts on the chassis. See [Figure 6-38](#) for details.
-

Figure 6-39 Installing the PoE Converter Power Supply

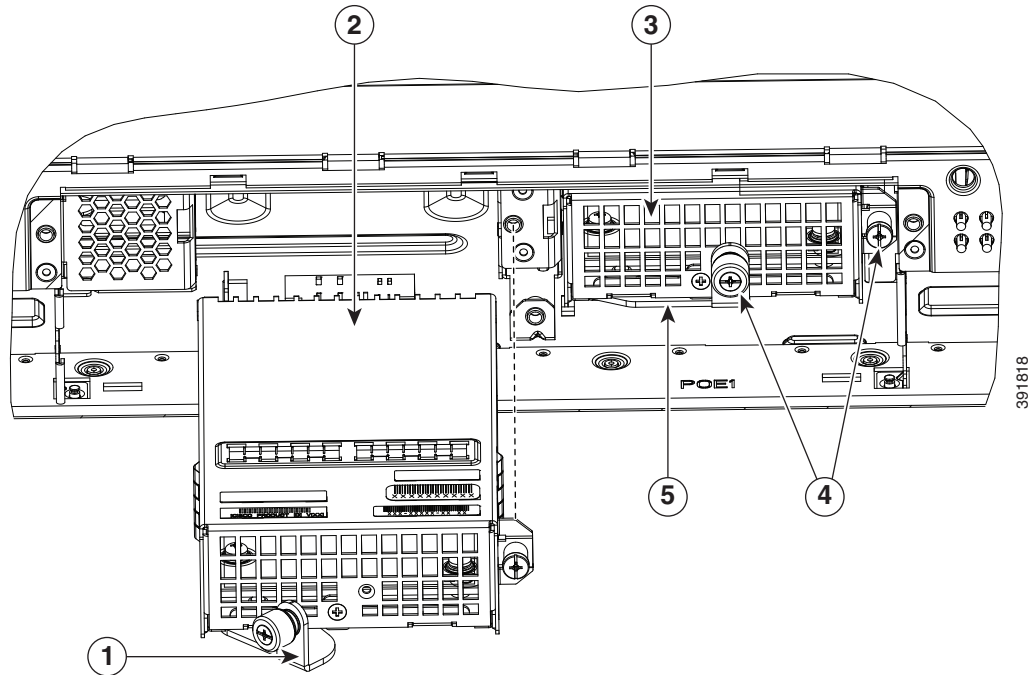

1	Latch to secure module (shown open).	2	PoE converter module being installed in PoE slot 0.
3	PoE converter module installed in PoE slot 1.	4	Screws to secure PoE module to router chassis.
5	Latch to secure PoE converter module (shown closed).		

Warning

Care should be taken while removing the power supplies and power inverters (especially in boost mode of operation). If the total power consumption is higher than can be supported by one power supply alone and in this condition a power supply is removed, the hardware can be damaged. This may then result in the system being unstable or unusable.

The following messages are expected behavior when you try to reload or insert a PoE supply in a router with Ethernet Switch Network Module:

```
*Jul 21 22:35:23.868: %IOSXE_PEM-6-INSPEM_FM: PEM/FM slot POE0 inserted
```

Upon PoE converter power supply insertion, inline power supply restores automatically in the router. After the insertion, resets are needed for the switch modules in the router for the PoE supply to work properly.

If there are two PoE supplies, the power supplies can operate in a boost mode or redundant mode. In a boost mode, the total power supplied is a sum of the two power supplies capacity. In a redundant mode, if one of the PoE supply fails, the other PoE will supply power.

Replacing a Fan Tray

The Cisco 4000 Series ISRs have hot-swappable fan trays that are field replaceable units (FRUs). The fan tray includes all of the router fans in one assembly. If a fan fails, replace the tray using a flat-blade or Phillips screwdriver.

**Note**

The Cisco ISR4331 and Cisco ISR4321 do not have hot-swappable fan trays.

Before Hot-Swapping a Fan Tray

Before hot-swapping a fan tray, read the safety precautions below.

- Read the entire procedure and have the required tools available.
- Do not attempt the hot-swap in ambient air temperature above 90°F (32°C).
- Do not attempt the hot-swap at an altitude above 6000 feet (1829 meters).
- When the router is being operated, it is recommended to change the fans in the router within 2 minutes to ensure the router does not overheat:

Replacing the Fan Tray

To replace the fan tray, perform these steps:

**Note**

If hot-swapping the fan tray, it is recommended to complete the operation within two minutes to ensure the router remains within operating temperature.

-
- Step 1** Remove the bezel. The bezel is secured with snap latches. To remove the bezel, hold the top and bottom and pull the bezel.
 - Step 2** Completely loosen the three captive fan tray screws.
 - Step 3** Pull the fan tray out.
 - Step 4** Insert the replacement fan tray and tighten the three captive screws.
 - Step 5** Replace the bezel.
-

Figure 6-40 Cisco ISR4351 Fan Tray

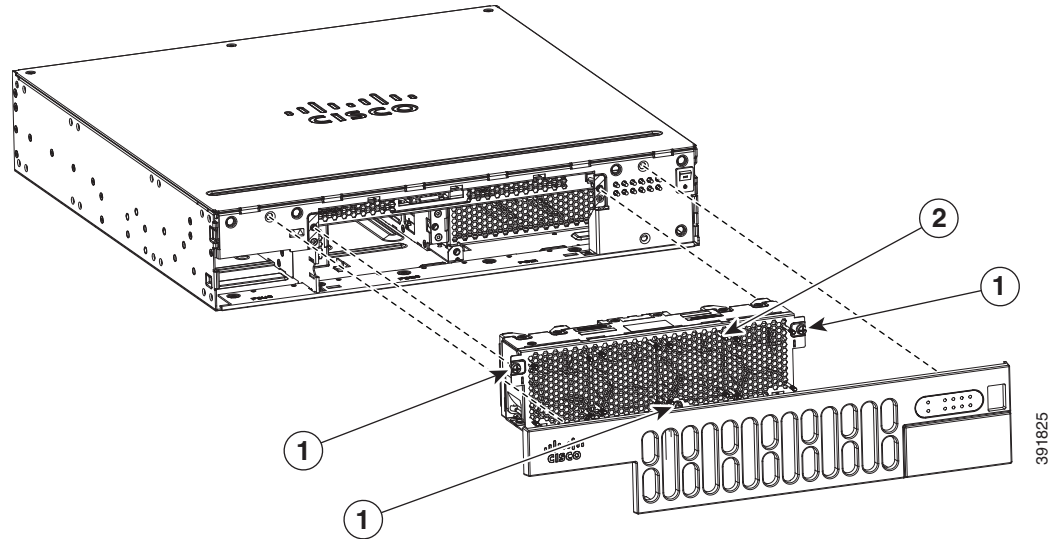

1	Captive screws	2	Fan tray
---	----------------	---	----------

Figure 6-41 Cisco 4431 ISR Fan Tray

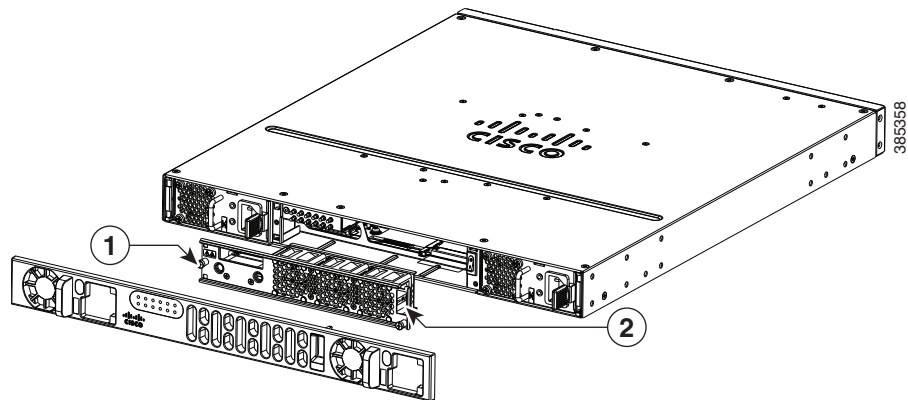

1	Captive screws	2	Fan tray
---	----------------	---	----------

Replacing the Fan Tray on a Cisco 4331 ISR

To replace the fan tray, perform these steps:

Step 1 Remove the four cover screws from the top of the chassis.



Note The length of the cover screw on top of the chassis is shorter.

- Step 2** Remove the two cover screws from each side of the chassis and lift the cover away from the router chassis. See [Figure 6-42](#).
- Step 3** Remove the fan connectors from the motherboard. See [Figure 6-43](#).
- Step 4** Press the spring-lock on both the sides of the fan tray to release the spring-lock.
- Step 5** Pull the fan tray up to disengage from the slot. See [Figure 6-42](#).
- Step 6** Insert the replacement fan tray and gently push down until the spring-lock is latched and fully engaged onto the slot.
- Step 7** Connect the fan connectors on the motherboard. See [Figure 6-43](#).

**Note**

The connectors are polarized/keyed to allow easy insertion only in one orientation. Orient the connectors correctly before you insert them. Incorrect orientation can damage the connector pins.

- Step 8** Turn on the system power and verify that the fan tray is functioning normally.
- Step 9** Turn off the system power before you cover over the chassis.
- Step 10** Center the cover over the chassis and lower it onto the chassis.
- Step 11** Install the four cover screws (torque 5 to 6 in-lb) on the top of the chassis and install the two cover screws (torque 5 to 6 in-lb) on each side of the chassis. See [Figure 6-42](#).

Figure 6-42 Cisco 4331 ISR Fan Tray

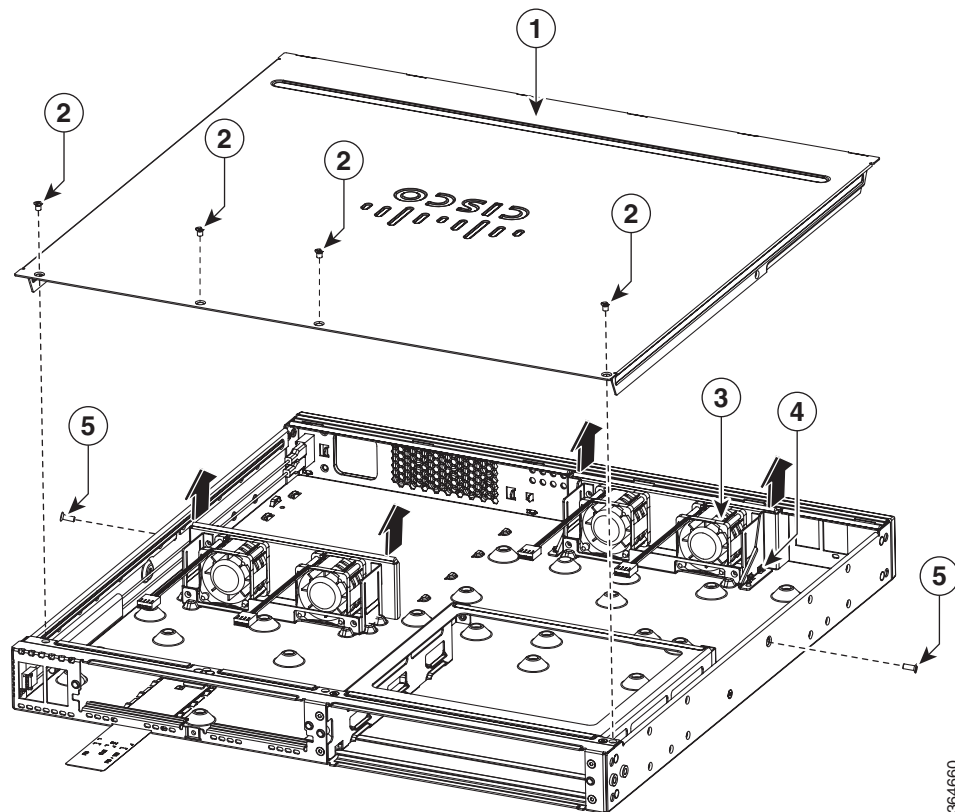

364660

1	Chassis cover	3	Fan tray
2	Cover screws (4)	4	Spring-lock
5	Cover screws on the side of the chassis (2)		

Figure 6-43 Cisco ISR 4331 Fan Connectors

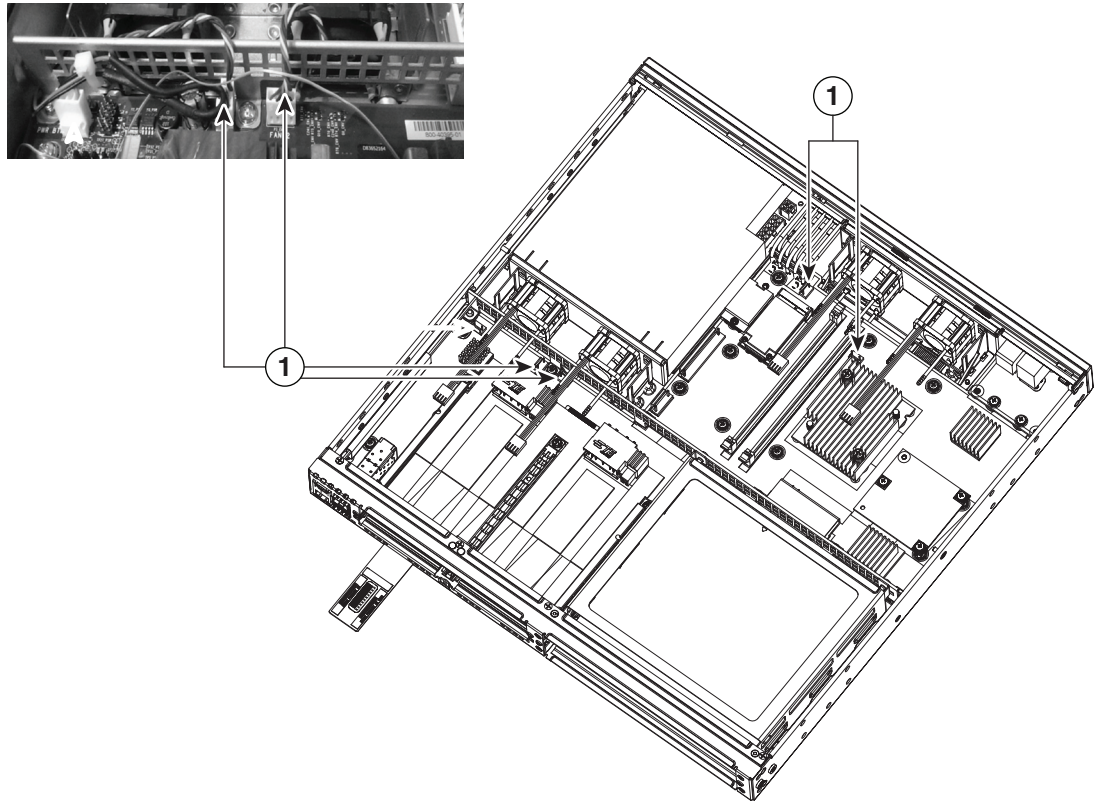

364704

1	Fan connectors (2)		
---	--------------------	--	--

Figure 6-44 Cisco ISR 4331 Fan Tray

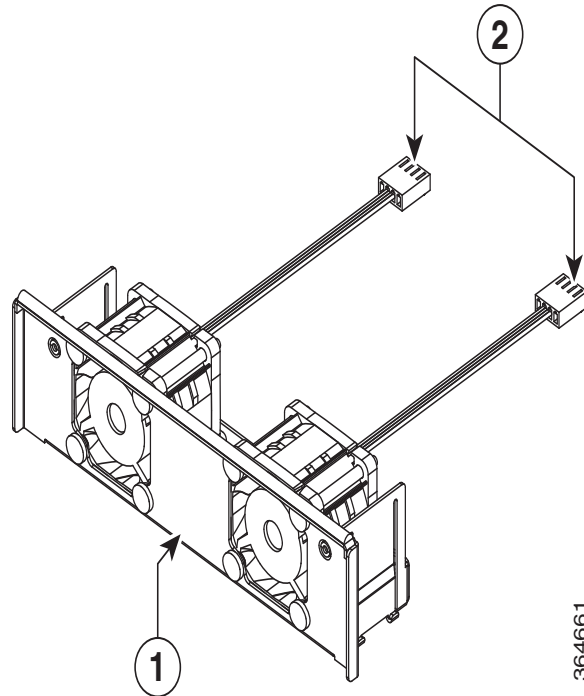

1	Fan tray	2	Fan connectors
---	----------	---	----------------

Removing and Installing a CompactFlash Memory Card

This section describes installing and replacing CompactFlash (CF) memory cards in the router. This applies only to the Cisco ISR 4451-X routers. It contains the following sections:

- [Preventing Electrostatic Discharge Damage, page 6-58](#)
- [Removing a CompactFlash Memory Card, page 6-59](#)
- [Installing a CompactFlash Memory Card, page 6-60](#)



Note

You must turn off the power supply to the router to replace a CompactFlash Memory card. A CompactFlash memory card must be inserted in order to run a Cisco IOS XE software image.

Preventing Electrostatic Discharge Damage

CF memory cards are sensitive to electrostatic discharge (ESD) damage, which can occur when electronic cards or components are handled improperly. ESD results in complete or intermittent failures.

To prevent ESD damage, follow these guidelines:

- Always use an ESD wrist or ankle strap and ensure that it makes good skin contact.
- Connect the equipment end of the strap to an unfinished chassis surface.

- Place CF memory cards on an anti-static surface or in a static shielding bag. If the card will be returned to the factory, immediately place it in a static shielding bag.
- Avoid contact between the card and clothing. The wrist strap protects the card from ESD voltages on the body only; ESD voltages on clothing can still cause damage.
- Do not remove the wrist strap until the installation is complete.

**Caution**

For safety, periodically check the resistance value of the anti-static strap. The measurement should be between 1 and 10 megohms (Mohms).

Removing a CompactFlash Memory Card

To remove a CF memory card from the chassis, perform these steps:

**Caution**

Do not remove a CF memory card from the chassis while it is being accessed. Cisco recommends not removing the CF when in Cisco IOS-XE at all. Either power the system off or fall back to the rommon prompt, if removing the CF.

- Step 1** Read the “[Safety Warnings](#)” section on page 6-2 section and disconnect the power supply before you perform any module replacement.
- Step 2** Remove the bezel.
- Step 3** Remove the fan tray. For instructions on removing the fan tray, see “[Replacing the Fan Tray](#)” section on page 6-54.
- Step 4** Remove the CF cover by placing a flat-blade screwdriver in the slot and pushing sideways against the tensioner to release the cover door.

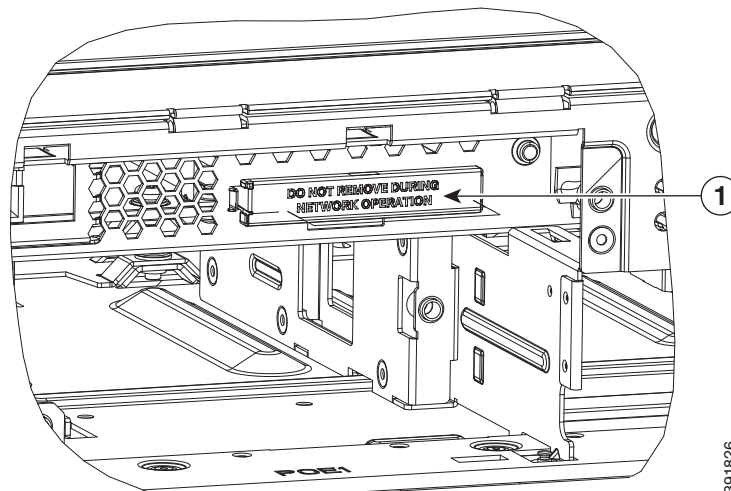

- | | |
|----------|---------------------|
| 1 | Compact flash cover |
|----------|---------------------|

- Step 5** Press the ejector button next to the CompactFlash memory card. The ejector button moves outward so that it projects from the panel.

- Step 6** Press the ejector button again. This ejects the CompactFlash memory card partially out of its slot.
- Step 7** Pull the CF memory card out of its slot.
- Step 8** Push the ejector button in until the button is flush with the bezel.



Caution To prevent damage to the ejector mechanism, the ejector button must remain pressed all the way in (flush against the bezel) when not being used to eject a CompactFlash memory card.

- Step 9** Replace the fan tray and then the bezel.

Installing a CompactFlash Memory Card

To install a CompactFlash memory card, perform these steps:

- Step 1** Read the [“Safety Warnings” section on page 6-2](#) and disconnect the power supply before you perform any module replacement.
- Step 2** Remove the fan tray. For instructions on removing the fan tray, see [“Replacing the Fan Tray” section on page 6-54](#).
- Step 3** Make sure that the ejector button is fully seated until it is flush with the bezel.



Note If the ejector button is projecting out from the panel, push it in until it is flush with the bezel.

- Step 4** Insert the CompactFlash memory card into the slot until it is fully seated. The ejector button remains flush with the panel.



Note If the ejector button is projecting from the panel after you insert the CompactFlash memory card, remove the CompactFlash memory card, press the ejector button until it clicks, and reinsert the CompactFlash memory card.



Caution To prevent damage to the ejector mechanism, the ejector button must remain fully seated when not being used to eject a CompactFlash memory card.

- Step 5** Replace the CompactFlash cover by inserting the cover lip into the chassis and pushing the cover to snap it back into place.
- Step 6** Replace the fan tray.

Removing and Installing a Flash Memory Card

This section describes installing and replacing flash memory cards in the router. It contains the following sections:

- [Preventing Electrostatic Discharge Damage](#), page 6-58
- [Installing the Flash Memory Card](#), page 6-61
- [Removing the Flash Memory Card](#), page 6-63

Preventing Electrostatic Discharge Damage

Flash memory cards are sensitive to electrostatic discharge (ESD) damage, which can occur when electronic cards or components are handled improperly. ESD results in complete or intermittent failures.

To prevent ESD damage, follow these guidelines:

- Always use an ESD wrist or ankle strap and ensure that it makes good skin contact.
- Connect the equipment end of the strap to an unfinished chassis surface.
- Place flash memory cards on an anti static surface or in a static shielding bag. If the card will be returned to the factory, immediately place it in a static shielding bag.
- Avoid contact between the card and clothing. The wrist strap protects the card from ESD voltages on the body only; ESD voltages on clothing can still cause damage.
- Do not remove the wrist strap until the installation is complete.



Caution

For safety, periodically check the resistance value of the anti static strap. The measurement should be between 1 and 10 megohms (Mohms).

Installing the Flash Memory Card

To install a flash memory card, perform the following steps:

-
- Step 1** Read the [“Safety Warnings”](#) section on page 6-2 and disconnect the power supply before you perform any module replacement.
 - Step 2** Remove the chassis cover. For instructions on removing the chassis cover, see [“Replacing the Chassis Cover”](#) section on page 6-5.
 - Step 3** Place the flash memory card on top of the flash memory card connector (see [Figure 6-45](#)).

Figure 6-45 Memory Cards

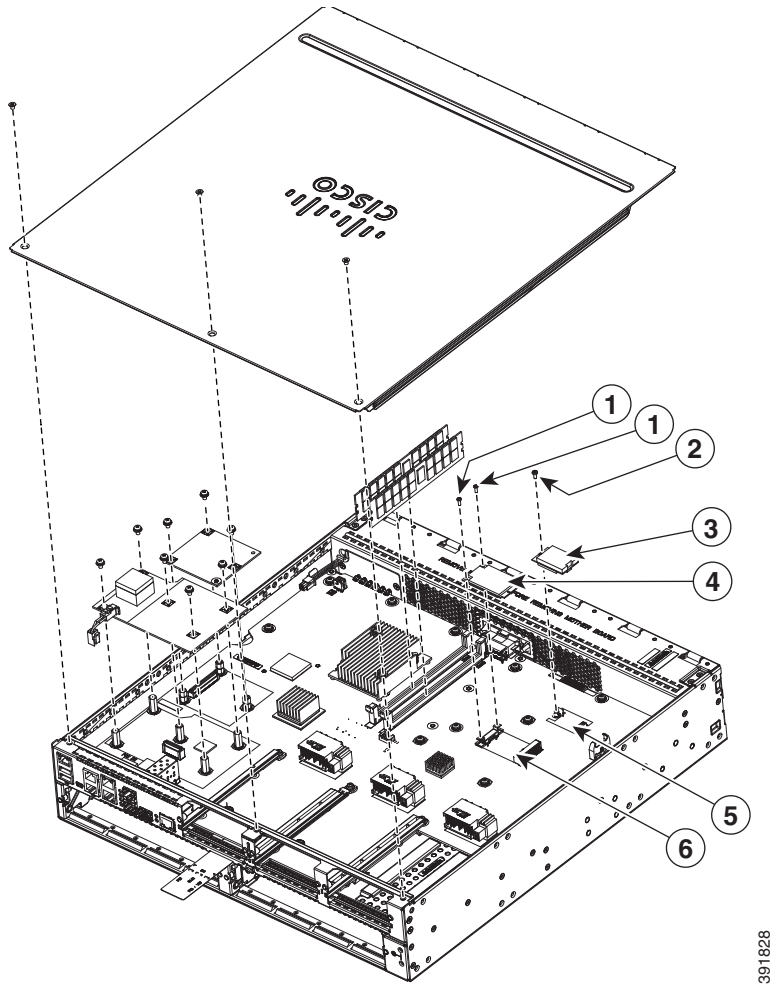

1	Supplied screw	2	Supplied screw
3	Flash memory card	4	SSD mSATA storage device
5	Flash memory card connector	6	SSD mSATA connector

Step 4 Tighten the supplied screw (see [Figure 6-45](#)) to secure the flash memory card in place.

Step 5 Replace the chassis cover. See “[Replacing the Chassis Cover](#)” section on page 6-5.

Removing the Flash Memory Card

To remove the Flash memory card, perform the following steps:

-
- Step 1** Read the “[Safety Warnings](#)” section on page 6-2 and disconnect the power supply before you perform any module replacement.
 - Step 2** Remove the chassis cover. For instructions on removing the chassis cover, see “[Replacing the Chassis Cover](#)” section on page 6-5.
 - Step 3** Unscrew the flash memory card, see [Figure 6-45](#).
 - Step 4** Install a new flash memory card if needed. See [Installing the Flash Memory Card](#), page 6-61.
 - Step 5** Replace the chassis cover. See “[Replacing the Chassis Cover](#)” section on page 6-5.
-

Installing and Removing an SSD mSATA Storage Device

This section describes installing and replacing an SSD mSATA storage device in Cisco ISR 4300 routers.

- [Preventing Electrostatic Discharge Damage](#), page 6-58
- [Installing the SSD mSATA Storage Device](#), page 6-64
- [Removing the SSD mSATA Storage Device](#), page 6-65

Preventing Electrostatic Discharge Damage

The SSD mSATA storage devices are sensitive to electrostatic discharge (ESD) damage, which can occur when electronic cards or components are handled improperly. ESD results in complete or intermittent failures.

To prevent ESD damage, follow these guidelines:

- Always use an ESD wrist or ankle strap and ensure that it makes good skin contact.
- Connect the equipment end of the strap to an unfinished chassis surface.
- Place the SSD mSATA storage devices on an anti-static surface or in a static shielding bag. If the device will be returned to the factory, immediately place it in a static shielding bag.
- Avoid contact between the device and clothing. The wrist strap protects the device from ESD voltages on the body only; ESD voltages on clothing can still cause damage.
- Do not remove the wrist strap until the installation is complete.



Caution

For safety, periodically check the resistance value of the anti static strap. The measurement should be between 1 and 10 megohms (Mohms).

Installing the SSD mSATA Storage Device

To install a SSD mSATA storage device, perform the following steps:

- Step 1** Read the “[Safety Warnings](#)” section on page 6-2 and disconnect the power supply before you perform any module replacement.
- Step 2** Remove the chassis cover. For instructions on removing the chassis cover, see “[Replacing the Chassis Cover](#)” section on page 6-5.
- Step 3** Place the SSD mSATA storage device on the SSD mSATA connector and align the device’s contact edge with the corresponding socket in the connector.
- Step 4** Press the device downward into the connector until it is level with the surface of the connector.
- Step 5** While holding the device down, screw the device into place (see [Figure 6-46](#)).

Figure 6-46 Flash Memory Card and SSD mSATA Storage Device Locations

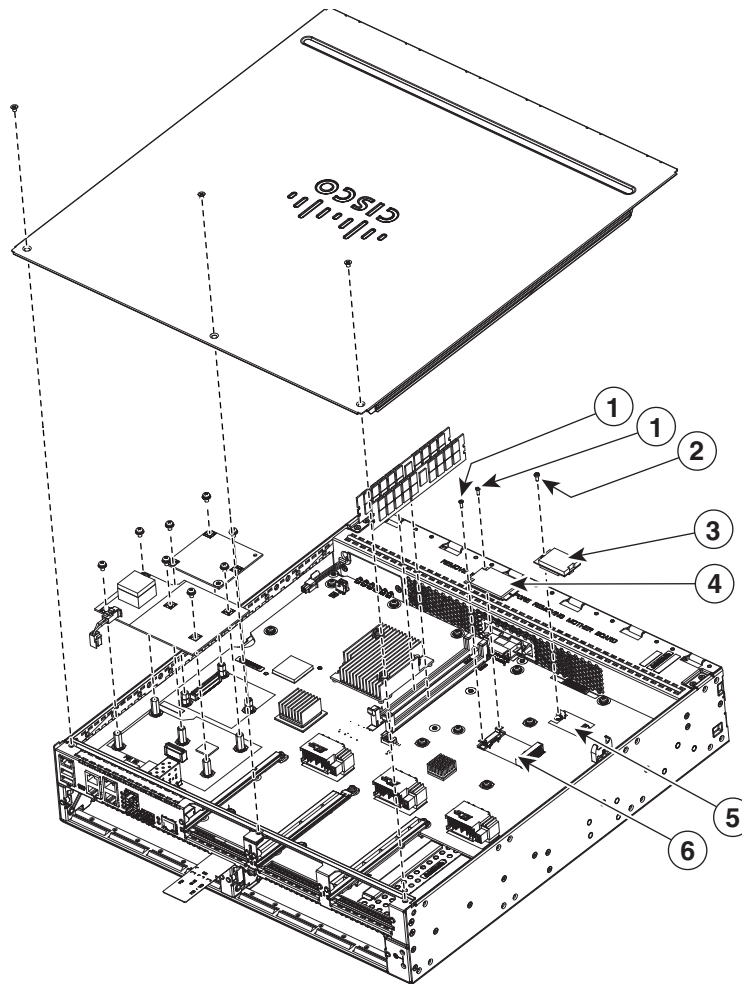

1	Supplied screw	2	Supplied screw
3	Flash memory card	4	SSD mSATA storage device
5	Flash memory card connector	6	SSD mSATA connector

- Step 6** Replace the chassis cover. See [“Replacing the Chassis Cover” section on page 6-5](#).
-

Removing the SSD mSATA Storage Device

To remove the SSD mSATA storage device, perform the following steps:

-
- Step 1** Read the [“Safety Warnings” section on page 6-2](#) and disconnect the power supply before you perform any module replacement.
- Step 2** Remove the chassis cover. For instructions on removing the chassis cover, see [“Replacing the Chassis Cover” section on page 6-5](#).
- Step 3** Unscrew the screws that attach the SSD mSATA storage device to the chassis. See [Figure 6-45](#).
- Step 4** The card should popup once the screws are removed.
- Step 5** Install a new SSD mSATA memory device if needed. See [Installing the SSD mSATA Storage Device, page 6-64](#).
- Step 6** Replace the chassis cover. See [“Replacing the Chassis Cover” section on page 6-5](#).
-

Installing and Removing SFP Modules

This section describes how to install optional small-form-factor pluggable (SFP) modules in the router to provide optical Gigabit Ethernet connectivity.

The SFP module installs into a slot on the router rear panel. When selected in Cisco IOS software, it is assigned port **gigabitethernet 0/0/0**. The default is the built-in RJ-45 1000Base-T connector, which is enabled on this port.

Only SFP modules certified by Cisco are supported on the routers. [Table 6-5](#) lists supported SFPs on the router.

See [Cisco Transceiver Modules Compatibility Information](#) for compatibility issues.

Table 6-5 SFPs Supported on the Router

Cisco Model Number	SFP Transceiver	Fiber Diameter (micrometer)	Wavelength (nm)	Mode	Maximum Distance
GLC-SX-MM=	1000Base-SX	50	850	Multi	550 m
GLC-LH-SM-X=	1000Base-LX/LH	9/125	1310	Single	10 km
GLC-ZX-SM-X=	1000Base-ZX	9/125	1550	Single	100 km
CWDM-SFP-1470=	1000Base-CWDM	50	1470	Single	100 km
CWDM-SFP-1490=			1490		
CWDM-SFP-1510=			1510		
CWDM-SFP-1530=			1530		
CWDM-SFP-1550=			1550		
CWDM-SFP-1570=			1570		
CWDM-SFP-1590=			1590		
CWDM-SFP-1610=			1610		
DWDM-SFP-3033			1000BASE-DWDM		
DWDM-SFP-3112	1000BASE-DWDM	—	1531.12	—	—
DWDM-SFP-3190	1000BASE-DWDM	—	1531.90	—	—
DWDM-SFP-3268	1000BASE-DWDM	—	1532.68	—	—
DWDM-SFP-3425	1000BASE-DWDM	—	1534.25	—	—
DWDM-SFP-3504	1000BASE-DWDM	—	1535.04	—	—
DWDM-SFP-3582	1000BASE-DWDM	—	1535.82	—	—
DWDM-SFP-3661	1000BASE-DWDM	—	1536.61	—	—
DWDM-SFP-3819	1000BASE-DWDM	—	1538.19	—	—
DWDM-SFP-3898	1000BASE-DWDM	—	1539.77	—	—
DWDM-SFP-3977	1000BASE-DWDM	—	1539.98	—	—
DWDM-SFP-4056	1000BASE-DWDM	—	1540.56	—	—
DWDM-SFP-4214	1000BASE-DWDM	—	1542.14	—	—
DWDM-SFP-4294	1000BASE-DWDM	—	1542.94	—	—
DWDM-SFP-4373	1000BASE-DWDM	—	1543.73	—	—

Table 6-5 SFPs Supported on the Router (continued)

Cisco Model Number	SFP Transceiver	Fiber Diameter (micrometer)	Wavelength (nm)	Mode	Maximum Distance
DWDM-SFP-4453	1000BASE-DWDM	—	1544.53	—	—
DWDM-SFP-4612	1000BASE-DWDM	—	1546.12	—	—
DWDM-SFP-4692	1000BASE-DWDM	—	1546.92	—	—
DWDM-SFP-4772	1000BASE-DWDM	—	1547.72	—	—
DWDM-SFP-4851	1000BASE-DWDM	—	1548.51	—	—
DWDM-SFP-5012	1000BASE-DWDM	—	1550.12	—	—
DWDM-SFP-5092	1000BASE-DWDM	—	1550.92	—	—
DWDM-SFP-5172	1000BASE-DWDM	—	1551.72	—	—
DWDM-SFP-5252	1000BASE-DWDM	—	1552.52	—	—
DWDM-SFP-5413	1000BASE-DWDM	—	1554.13	—	—
DWDM-SFP-5494	1000BASE-DWDM	—	1554.94	—	—
DWDM-SFP-5575	1000BASE-DWDM	—	1555.75	—	—
DWDM-SFP-5655	1000BASE-DWDM	—	1556.55	—	—
DWDM-SFP-5817	1000BASE-DWDM	—	1558.17	—	—
DWDM-SFP-5898	1000BASE-DWDM	—	1558.98	—	—
DWDM-SFP-5979	1000BASE-DWDM	—	1559.79	—	—
DWDM-SFP-6061	1000BASE-DWDM	—	1560.61	—	—
GLC-BX-D			1490 TX	—	—
			1310 RX	—	—
GLC-BX-U			1310 TX	—	—
			1490 RX	—	—
GLC-FE-100FX	—	—	1310	Multi	2 km
GLC-FE-100LX	—	—	1310	Single	10 km
GLC-FE-100EX	100BASE-FX	—	1310	Single	40 km
GLC-FE-100ZX	100BASE-ZX	—	1550	Single	80 km
GLC-FE-100BX-U			1310 TX	Single	10 km
			1550 RX		
GLC-FE-100BX-D			1550 TX	Single	10 km
			1310 RX		
GLC-GE-100FX	—	—	1310	Multi	2 km

**Tip**

Use the **show controller** command at the Cisco IOS prompt to determine whether you are using an SFP certified by Cisco.

Installing SFPs

Laser Safety Guidelines

Optical SFPs use a small laser to generate the fiber-optic signal. Keep the optical transmit and receive ports covered whenever a cable is not connected to the port.



Warning

Invisible laser radiation may be emitted from disconnected fibers or connectors. Do not stare into beams or view directly with optical instruments. Statement 1051



Warning

Ultimate disposal of this product should be handled according to all national laws and regulations. Statement 1040

Follow these steps to install an SFP module in your router:

- Step 1** Read the “[Safety Warnings](#)” section on [page 6-2](#) section and disconnect the power supply before you perform any module replacement.
- Step 2** Slide the SFP into the router connector until it locks into position (see [Figure 6-47](#)).



Tip

If the SFP uses a bale-clasp latch (see [Figure 6-47](#)), the handle should be on top of the SFP module.

Figure 6-47 Installing an SFP Module

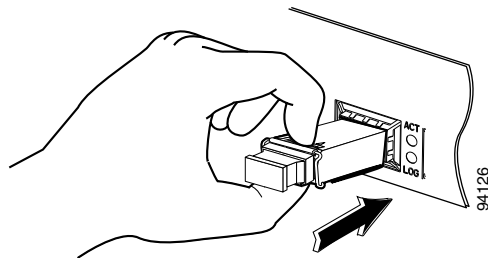

Caution

Do not remove the optical port plugs from the SFP until you are ready to connect cabling.

- Step 3** Connect the network cable to the SFP module.

Removing SFP Modules

Follow these steps to remove an SFP from the router:

Step 1 Read the “[Safety Warnings](#)” section on page 6-2 section and disconnect the power supply before you perform any module replacement.

Step 2 Disconnect all cables from the SFP.

Warning

Invisible laser radiation may be emitted from disconnected fibers or connectors. Do not stare into beams or view directly with optical instruments. Statement 1051

Caution

The latching mechanism used on many SFPs locks the SFP into place when cables are connected. Do not pull on the cabling in an attempt to remove the SFP.

Step 3 Disconnect the SFP latch. See [Figure 6-48](#).

Note

SFP modules use various latch designs to secure the module in the SFP port. Latch designs are not linked to SFP model or technology type. For information on the SFP technology type and model, see the label on the side of the SFP.

Figure 6-48 Disconnecting SFP Latch Mechanisms

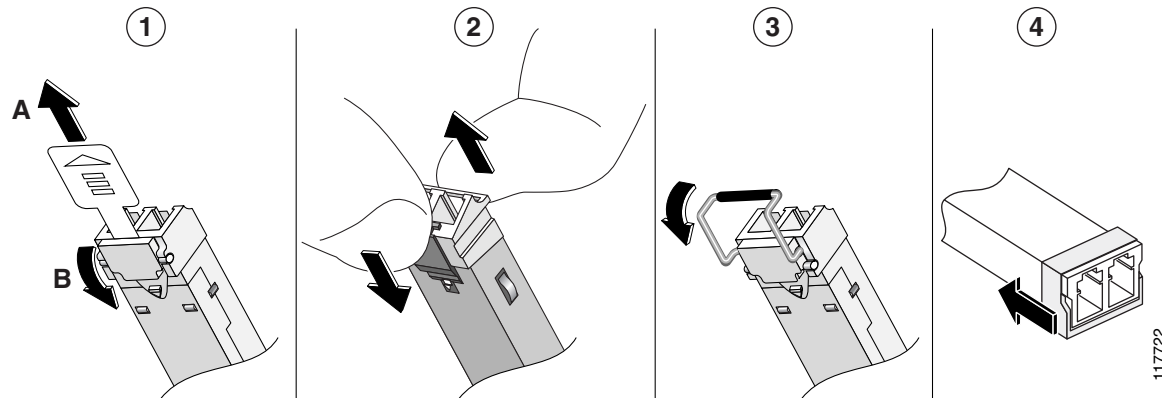

1	Sliding latch	3	Bale-clasp latch
2	Swing and slide latch	4	Plastic collar latch

Tip

Use a pen, screwdriver, or other small straight tool to gently release a bale-clasp handle if you cannot reach it with your fingers.

Step 4 Grasp the SFP on both sides and remove it from the router.

Removing, Replacing, and Installing an Internal PoE Daughter Card

Use the following procedure to install or replace an Internal PoE daughter card:

-
- Step 1** Read the “[Safety Warnings](#)” section on page 6-2 and disconnect the power supply before you perform any module replacement.
 - Step 2** Remove the five screws.
 - Step 3** Remove the power cable to motherboard.
 - Step 4** Access the PoE card slot. See the “[Replacing the Chassis Cover](#)” section on page 6-5.
 - Step 5** Locate the card to be removed or replaced. See [Figure 6-49](#) for the location of the PoE card on the motherboard.

Figure 6-49 Location of the PoE Daughter Card (Shown: Cisco ISR 4451-X)

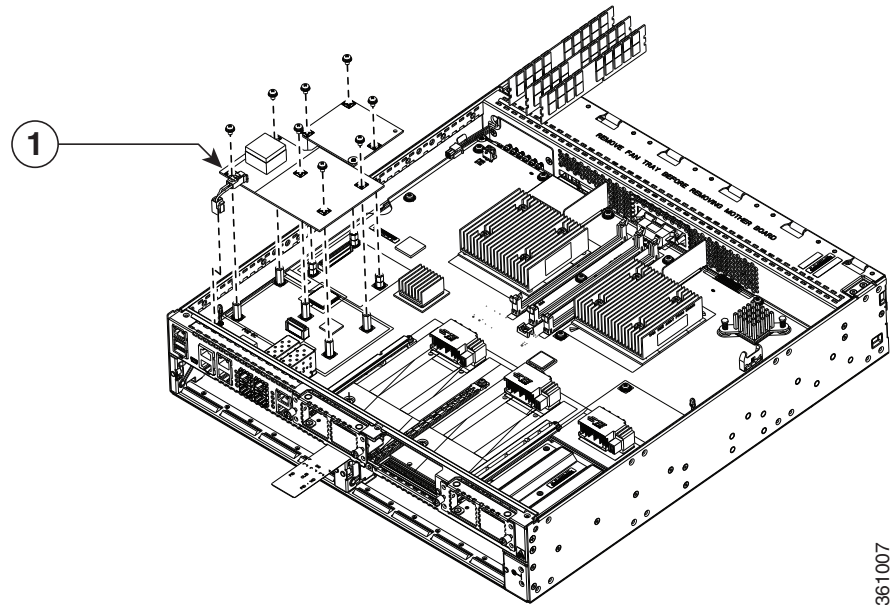

-
- | | |
|----------|---|
| 1 | Location of the PoE card on the mother board. |
|----------|---|
-

- Step 6** Pull the PoE daughter card out of the connector on the motherboard. If replacing the card, insert the new PoE daughter card into the slot. Tighten the screws, and connect the power cable to the motherboard.
 - Step 7** Place the removed card in an anti-static bag to protect it from ESD damage.
-



Online Insertion and Removal and Hot-Swapping

Online insertion and removal (OIR) enables you to replace faulty modules without affecting system operation, which is similar to hot-swapping. OIR commands are issued before removing a module and after installing a module. When performing OIR, an identical module must be used to replace the original one. If performing OIR on multiple modules within a router, perform the operation on one module at a time.

Requirement

The module must be in energywise full-power mode for OIR commands to be issued. If the module is in energywise power-saving or shutdown mode, OIR commands can not be issued, and the module should not be removed.

The difference between hot-swapping and OIR is that OIR requires performing Cisco IOS commands before and after the OIR. Hot-swapping is strictly a hardware function and requires no commands. Not all router components or modules use OIR, or can be hot swapped.

The following items use OIR in the routers:

- Service Modules (SMs)
- Network Interface Modules (NIMs)
- SFPs
- USB devices

The following items can be hot swapped:

- Fan tray
- Power supply—only when the router is backed up with the optional PSU

OIR Procedures

The following procedures describe using the OIR process to remove and replace data and voice modules.

Removing a Module

From a console terminal issue the **hw-module subslot <subslot> stop** command. The service module adapter LED blinks, then turns off, and the console displays a prompt signaling the module can be removed.



Note

Ensure that the module is available before you issue this command.

See the following output:

```
Router# hw-module subslot 2/0 stop
Proceed with stop of module? [confirm]
damo-O2#
*Mar 22 20:43:31.088: %SPA_OIR-6-OFFLINECARD: SPA (SM-X-1T3/E3) offline in subslot 2/0
*Mar 22 20:43:31.088: %IOSXE_OIR-6-SOFT_STOPSPA: SPA(SM-X-1T3/E3) stopped in subslot 2/0,
interfaces disabled
Router# show hw-module subslot 2/0 oir
Module           Model                Operational Status
-----
subslot 2/0     SM-X-1T3/E3         stopped
```

Inserting a Data or Voice Module

This step is only required if the **oir-stop** command was issued and the module was not physically removed from the slot. If the module was physically removed, this command is not needed.

From a console terminal issue the **hw-module sm {slot} oir-start** command. The console displays a output showing the module changing states. See the following output:

```
Router# hw-module sm 2 oir-start
Router#
*Nov 11 21:06:17.546: %ATMOC3POM-6-SFP_IN: Interface ATM2/0 OC3 MM SFP has been inserted.
Router#
*Nov 11 21:06:19.442: %LINK-3-UPDOWN: Interface ATM2/0, changed state to up
*Nov 11 21:06:20.442: %LINEPROTO-5-UPDOWN: Line protocol on Interface ATM2/0, changed
state to up
```

Hot-Swapping Procedures

The following items can be hot-swapped:

- Fan trays
- Power supplies only when the router is backed up with an RPS

See the [“Replacing a Fan Tray”](#) section on page 6-54 and the [“Removing and Replacing the Cisco 4000 Series ISRs Power Supplies”](#) section on page 6-39.